



# Shop Drawing Review

Queen's Quay Terminal  
207 Queen's Quay West, Suite 615  
Toronto, Ontario, M5J 1A7  
Phone (416) 598-2920 Fax (416) 598-5394  
www.mcw.com

Date: April 29, 2026

Project Name: Durham College – A and B Wings AHU

Project #: 24333-08

Client: Durham College

Rev #: 0

To: Mic Mechanical Contracting Ltd.

Page #: 1 of 2

Attention: Meaghan Rice (meaghan@micmechanical.com)

+ Attachment

From: Toronto Shop Drawings ([TOR.ShopDrawings@mcw.com](mailto:TOR.ShopDrawings@mcw.com))

Distribution: James Waters (james@micmechanical.com)

Steven Bush (sbush@mcw.com)

This review by MCW Consultants Ltd. is for the sole purpose of ascertaining conformance with the general design concept. This review shall not mean that the Consultant approves the detail design inherent in the shop drawings, responsibility for which shall remain with the Contractor submitting same, and such review shall not relieve the Contractor of his responsibility for errors or omissions in the shop drawings or of his responsibility for meeting all requirements of the Contract Documents. The Contractor is responsible for dimensions to be confirmed and correlated at the job site, for information that pertains solely to fabrication, means, methods, techniques, sequences or procedures of construction, coordination of the Work of all trades, and for performing all work in a safe and satisfactory manner.

## Subject: MUA-ALT-1.pdf

- |   |   |
|---|---|
| <input type="checkbox"/> <b>NOT REVIEWED</b><br>Input from MCW is not required  | <input checked="" type="checkbox"/> <b>REVIEWED</b><br>No further review or re-submission is required                           |
| <input type="checkbox"/> <b>RESUBMIT</b><br>Incorporate the noted corrections; re-submission is required                                      | <input type="checkbox"/> <b>REVIEWED AS MODIFIED</b><br>Incorporate the noted corrections; re-submission is <u>not</u> required |
| <input type="checkbox"/> <b>NOT SPECIFIED BY MCW, REVIEWED FOR MEP ONLY</b><br>Reviewed to confirm compliance with MEP services provided only |   |

**Electrical Reviewer:**

**Mechanical Reviewer:**

R. Armaleh

T. Tisler

### 1. General Comments:

- 1.1. Quantities were not reviewed unless specifically noted otherwise. It is the Contractor's responsibility to confirm all quantities and provide the amounts required per Contract Documents.
- 1.2. Equipment connection locations, mounting details, etc. were not reviewed. Contractor to confirm such details in coordination with site conditions and all other divisions concerned prior to release.
- 1.3. Contractor to site confirm all equipment and component dimensions, orientations, clearances, and service space requirements prior to release.
- 1.4. Architect to review all colours, finishes, wall, floor, and ceiling connection details as applicable.
- 1.5. Acoustical Consultant to review sound power levels as applicable.
- 1.6. Structural Engineer to review all equipment weights.



Project Name: Durham College – A and B Wings AHU

To: Mic Mechanical Contracting Ltd.

Attention: Meaghan Rice (meaghan@micmechanical.com)

Project #: 24333-08

Rev #: 0

Page #: 2 of 2

---

**2. Additional Comments:**

Electrical: reviewed. no comment.

***\*Review all subsequent pages for any further comments and/or modifications that may have been applied.***

Should you have any questions or concerns with this review, please contact the Construction Administrator assigned to the project directly.

**End of Review**



**Mic Mechanical**

**Mic Mechanical Contracting Ltd.**

14 – 1084 Salk Road  
Pickering, Ontario  
L1W 4B6

April 27, 2026

**MCW Engineering**

**Attention:**

**Job #26032 – Durham College**

1610 Champlain Drive  
Whitby, Ontario  
L1N 6A7

**Supplier:** HTS  
**Equipment:** MUA-ALT-1  
**Specification Section:** 00  
**Revision Number:** 00

Please see attached shop drawings for review.

Thank you,

Meaghan Rice  
Mic Mechanical Contracting Ltd.

**Shop Drawing  
Review**

**Mic Mechanical  
Contracting Ltd**

**REVIEWED**

*By James Waters at 12:29 pm, Apr 27, 2026*

**Date:** \_\_\_\_\_



**SHOP DRAWING REVIEW  
PER M/E SPECIFICATIONS SECTIONS**

DATE

**2026/04/29**

PROJECT No.

**24333-08**

NOT REVIEWED

REVIEWED

RESUBMIT

REVIEWED AS MODIFIED

NOT SPECIFIED BY MCW, REVIEWED FOR MEP ONLY

ELECTRICAL REVIEWER:

R.A

MECHANICAL REVIEWER:

TT

**Submittal # 99169**

**APPROVAL REQUIRED**

**Project** 22603112-MECH-1- Durham College Welding HVAC Reno  
**Leader** Danny Russell  
**Job Site** 1610 Champlain Ave, Whitby, ON, Canada  
**Submission Date** 2026-04-27  
**Sold To** MIC MECH CONTRACTING  
**Submitted By** Danny Russell

**Contacts**

Role	Customer	Our Rep
Designer	MCW Consultants Ltd.*	Paul Povolo
Owner	Durham College *	Curtis Metrow
Project Coordinator	Mic Mechanical Contracting Ltd. *	Danny Russell

**Deliverables**

Track #	341611		
Tag	MUA-ALT-1		
Description	Make-Up Air Unit		
Quantity	1		
Manufacturer	Modine		
Model #	HDP500		
Specification	23-73-14		
Production Start Date			
Production Lead Time	7 - 9 weeks		
Delivery Finish Date			
Revision #	0		

**Attention:**

- 1) HTS will provide equipment in accordance with the attached shop drawings.
- 2) Upon approved submittal and customer release, HTS will release equipment to fabrication per the published lead times. Any storage fees associated with project schedule changes will be the responsibility of the purchaser.
- 3) HTS can provide freight and logistics to the purchaser as an added benefit of doing business with HTS. When freight is received by the purchaser, any noticeable damage must be recorded. Otherwise, HTS is not responsible for subsequent damage claims.

	<b>SHOP DRAWING REVIEW</b> PER M/E SPECIFICATIONS SECTIONS	
	DATE <b>2026/04/29</b>	PROJECT No. <b>24333-08</b>
<input type="checkbox"/> NOT REVIEWED	<input checked="" type="checkbox"/> REVIEWED	
<input type="checkbox"/> RESUBMIT	<input type="checkbox"/> REVIEWED AS MODIFIED	
<input type="checkbox"/> NOT SPECIFIED BY MCW, REVIEWED FOR MEP ONLY		
ELECTRICAL REVIEWER: <u>R.A.</u>	MECHANICAL REVIEWER: <u>TT</u>	

**Approval Stamps**

	<b>SHOP DRAWING REVIEW</b> PER M/E SPECIFICATIONS SECTIONS
DATE <b>2026/04/29</b>	PROJECT No. <b>24333-08</b>
<input type="checkbox"/> NOT REVIEWED	<input checked="" type="checkbox"/> REVIEWED
<input type="checkbox"/> RESUBMIT	<input type="checkbox"/> REVIEWED AS MODIFIED
<input type="checkbox"/> NOT SPECIFIED BY MCW, REVIEWED FOR MEP ONLY	
ELECTRICAL REVIEWER: <u>R.A.</u>	MECHANICAL REVIEWER: <u>TT</u>



**PART 1 - GENERAL**

**1.1. SECTION INCLUDES**

1.1.1. General description of the Work.

**1.2. WORK COVERED BY THE EQUIPMENT PRE-TENDER DOCUMENTS**

1.2.1. Work of this Equipment Pre-tender Bid consists of the effort related to the;

1.2.1.1. Supply and delivery of one AHU outlined in this document to the Owner's site. Delivery of all equipment shall be to **the loading dock located at 1610 Champlain Ave., Whitby.**

✓ 1.2.2. All efforts required to coordinate the delivery of the equipment with the successful Trade Contractor (General Contractor responsible for installation) and/or Construction Manager. This includes responding to all requests for information and providing all guidance related to the proper installation of the equipment.

✓ 1.2.3. Provide sufficient resources to complete the work within the Agreement time. Any required overtime and similar costs to complete the project by the agreed completion date is included in the Bid price.

✓ 1.2.4. Co-ordinate and take sole responsibility as well as taking the lead role in the onsite testing, supervision of assembly and commissioning of the installation and verification of the performance of the equipment.

✓ 1.2.5. Work with the successful Trade Contractor (Mechanical Contractor responsible for installation) and/or Construction Manager to confirm the AHU supplied as part of this tender is installed correctly and is tested in advance to allow for the uninterrupted start-up and commissioning of the equipment.

✓ 1.2.6. Work with the controls contractor to assist in the installation and integration to the existing controls system.

1.2.7. ~~Ensure that all equipment meets all design and code requirements prior to shipment from the manufacturer's shop. Any rework on site will be at the Vendor/Equipment Supplier's cost.~~  
**shop drawings provided to ensure manufactured equipment meets requirements.**

1.2.8. The Vendor/Equipment Supplier shall provide on-site expertise during the installation of the equipment as follows:

~~1.2.8.1. Technical supervision of the Trade Contractor during assembly of the equipment (if required) as per manufacturer instructions.~~

~~1.2.8.2. On-site technical supervision of the Trade Contractor for the equipment and alignment as per the manufacturer's instructions prior to any start-ups.~~

~~1.2.8.3. Review of the electrical wiring and gas piping connections.~~

~~1.2.8.4. Assistance with the integration of the new equipment with the existing central controls system as required.~~

~~1.2.8.5. Technical supervision of start-up and commissioning of the equipment.~~

1.2.8.6. Equipment start-up and test by personnel trained and certified by the equipment manufacturer.

~~1.2.8.7. Complete, sign and submit all forms necessary for acceptance of the equipment by Owner and Consultant.~~

1.2.8.8. Shop drawing and auxiliary data.

1.2.8.9. Operator training for operating and maintaining the equipment.

**1.3. TRAINING**

✓ 1.3.1. The Vendor/Equipment Supplier shall include in their bid price provision for training for all equipment supplied as part of this package.

**1.4. SCHEDULING**

Installation is not included in this document and we have no information on the installation. Consultant to ensure that installation of unit is in accordance with IOM and all applicable codes.

	<b>SHOP DRAWING REVIEW</b> PER M/E SPECIFICATIONS SECTIONS
<b>DATE:</b> 2026/04/29	<b>PROJECT #:</b> 24333-08
<input type="checkbox"/> NOT REVIEWED	<input checked="" type="checkbox"/> REVIEWED
<input type="checkbox"/> RESUBMIT	<input type="checkbox"/> REVIEWED AS MODIFIED
<input type="checkbox"/> NOT SPECIFIED BY MCW, REVIEWED FOR MEP ONLY	
<b>ELECTRICAL REVIEWER:</b> R.A.	<b>MECHANICAL REVIEWER:</b> TT

- 1.4.1. The Vendor/Equipment Supplier shall prepare a preliminary manufacturing schedule, for presentation to the Owner and Consultant for review and acceptance. The schedule must meet the requirements of the RFP documents as follows:
  - 1.4.1.1. Purchase Order Issued: April 21, 2026
  - 1.4.1.2. Shop Drawings Submitted to MCW: April 29, 2026
  - 1.4.1.3. Approved Shop Drawings: May 1, 2026
  - 1.4.1.4. Equipment on Site: no later than July 20, 2026

**1.5. SUPPLEMENTARY REQUIREMENTS**

- 1.5.1. As part of the Bid submission, please include the following:
  - ✓ 1.5.1.1. Performance cutsheet showing:
    - 1.5.1.1.1. Performance.
    - 1.5.1.1.2. Equipment weight and overall dimensions.
    - 1.5.1.1.3. Electrical Requirements.
  - ✓ 1.5.1.2. General arrangement drawings showing all weights and dimensions with the inclusion of all auxiliary components
  - ✓ 1.5.1.3. Cutsheets for all applicable instrumentation, valves, components, and equipment.
  - 1.5.1.4. Wiring diagrams.
    - 1.5.1.4.1. Electrical
    - 1.5.1.4.2. Building Automation / Controls
  - 1.5.1.5. List of spare parts provided if any.
  - 1.5.1.6. Include service and maintenance manuals.
  - ✓ 1.5.1.7. Maintenance Requirements.
  - ✓ 1.5.1.8. Confirmation the equipment complies with all codes and standards – ESA, CSA, ASME, CRN, etc.
  - ✓ 1.5.1.9. Product certifications.
  - ✓ 1.5.1.10. Warranty terms and conditions

**PART 2 - PRODUCTS**

2.1. NOT USED

2.1.1. Not used.

**PART 3 - EXECUTION**

3.1. NOT USED

3.1.1. Not used.

	<b>SHOP DRAWING REVIEW</b>	
	PER M/E SPECIFICATIONS SECTIONS	
DATE	PROJECT No.	
<b>2026/04/29</b>	<b>24333-08</b>	
<input type="checkbox"/> NOT REVIEWED	<input checked="" type="checkbox"/> REVIEWED	
<input type="checkbox"/> RESUBMIT	<input type="checkbox"/> REVIEWED AS MODIFIED	
<input type="checkbox"/> NOT SPECIFIED BY MCW, REVIEWED FOR MEP ONLY		
ELECTRICAL REVIEWER:	MECHANICAL REVIEWER:	
<u>R.A.</u>	<u>TT</u>	

**END OF SECTION 01 10 10**

## CONTENTS

### PART 1 - GENERAL

- 1.01 DESCRIPTION
- 1.02 WORK PERFORMED BY THIS SECTION
- 1.03 REFERENCES
- 1.04 QUALITY ASSURANCE
- 1.05 SUBMITTALS
- 1.06 DELIVERY, STORAGE AND HANDLING
- 1.07 WARRANTY

### PART 2 - PRODUCTS

- 2.01 OUTSIDE AIR MAKE-UP UNIT, GAS FIRED

### PART 3 - EXECUTION

- 3.01 NIL

PART 1 - GENERAL

1.01 DESCRIPTION

.1 Comply with requirements of RFP #1 document.

1.02 WORK PERFORMED BY THIS SECTION

.1 Supply of outside make-up air units.

1.03 REFERENCES

.1 American National Standards Institute/Air-Conditioning and Refrigeration Institute (ANSI/ARI)

.1 ANSI/ARI 430, Central-Station Air-Handling Units.

.2 American Society of Heating, Refrigeration and Air Condition Engineers (ASHRAE)

.1 ANSI/ASHRAE 90.1, (I-P) Energy Standard for Buildings Except Low-Rise Residential Buildings.

.2 ANSI/ASHRAE 52.2, Method of Testing General Ventilation Air-Cleaning Devices for Removal Efficiency by Particle Size.

.3 Canadian General Standards Board (CGSB)

.1 CAN/CGSB 1.181, Ready-Mixed Organic Zinc-Rich Coating.

.4 Green Seal Environmental Standards (GSES)

.1 Standard GS-11, Environmental Standard for Paints.

.5 Master Painters Institute (MPI)

.1 MPI-INT 5.3, Galvanized Metal.

.6 South Coast Air Quality Management District (SCAQMD), California State (SCAQMD)

.1 SCAQMD Rule 1113, Architectural Coatings.

1.04 QUALITY ASSURANCE

.1 Certificates:

.1 Catalogue or published ratings those obtained from tests carried out by manufacturer or those ordered by manufacturer from independent testing agency.

.2 Acceptable manufacturers: ~~Reznor, Klimak, Mafra, Daikin~~ **Modine**

1.05 SUBMITTALS

✓.1 Provide manufacturer's printed product literature and datasheets for make-up air unit and include product characteristics, performance criteria, physical size, finish and limitations. Shop Drawings to include:

.1 Actual heating capacity for stated airside requirements.

	SHOP DRAWING REVIEW PER M/E SPECIFICATIONS SECTIONS	
	DATE <b>2026/04/29</b>	PROJECT No. <b>24333-08</b>
<input type="checkbox"/> NOT REVIEWED	<input checked="" type="checkbox"/> REVIEWED	
<input type="checkbox"/> RESUBMIT	<input type="checkbox"/> REVIEWED AS MODIFIED	
<input type="checkbox"/> NOT SPECIFIED BY MCW, REVIEWED FOR MEP ONLY		
ELECTRICAL REVIEWER: <u>R.A.</u>	MECHANICAL REVIEWER: <u>TT</u>	



- .1 Cabinet shall be fully weather-sealed to prevent water infiltration under all operating conditions. ☒
  - .2 All seams shall be gasketed or sealed.
  - .3 Unit shall include a weatherized control compartment with gasketed access doors.
  - .4 ✓ Insulation:
    - .1 Double-wall construction shall include internal insulation, minimum 1 in. (25 mm) thick.
    - .2 Insulation shall be non-hygroscopic, mold-resistant, and protected by inner liner.
    - .3 Insulation shall meet flame spread and smoke development requirements per applicable codes.
  - .5 Access panels: 450 mm wide minimum by full height of unit casing (less thickness of framing), insulated (sheetmetal lined) with zinc plated piano hinges with brass pins, ~~Ventlock 310 handles (openable from both sides)~~ for the following:
    - .1 Fans and motors
    - .2 Filters
    - .3 Dampers and actuators
    - .4 Access plenums
    - .5 Heating section
  - .6 ~~Drain pans: integral with floor panel, 50 mm deep, welded corners asphaltic water proofing coated, extended 150 mm downstream of coil face and with 25 mm drain connection.~~
  - .7 Outdoor air intake: hooded with 25 mm galvanized screens.
- .4 Roof mounting curb: full perimeter, constructed of heavy gauge sheetmetal, 400 mm high with wood nailer, neoprene sealing strip ~~and all welded "Z" bar with 25 mm upturn on inner perimeter.~~
- ✓.5 Fans: rated to AMCA Standard Test Code, Bulletin 210, factory dynamically balanced at 20% minimum below first critical RPM.
- ✓.1 Forward curved fans 450 mm and less to have permanently lubricated cartridge ball bearings supported by 3 point bearing bracket. Larger fans to have greaseable pillow block bearings supported on structural steel frame.
  - ✓.2 Air foil fans: bearings to be greaseable self-aligning ball or roller pillow block type.
  - ✓.3 Ratio of blast to nominal outlet areas: Forward curved 60%+  
Airfoil 75%+
  - ✓.4 Drives: adjustable for motors 3.73 kW (5hp) or smaller. fixed on larger motors.
  - ✓.5 Fan/motor assemblies: equipped with vibration isolators; neoprene-in-shear for 230 to 330 mm forward curved fans. Larger fans to have spring type isolators with levelling bolts with 25 mm deflection minimum.

**MCW**

DATE: **2026/04/29**

NOT REVIEWED

RESUBMIT

NOT SPECIFIED BY MCW, REVIEWED BY ONLY

ELECTRICAL REVIEWER: R.A.

MECHANICAL REVIEWER: TT

PER M/E SPECIFICATIONS SECTIONS

PROJECT NO: **24332-08**

CGA approved indirect fired heat exchanger.

Units shall be with steel die-formed atmospheric burners constructed with 409 E-3 stainless steel ribbon inserts. Burners shall be designed with a die-formed flared venturi inlet ports. Units provided with 409 E-3 stainless steel burner body construction.

Burner drip pan and unit bottom panel of 409 E-3 stainless steel shall be provided to manage condensation from heat exchanger cells.

Gas controls designed for makeup air heating applications. Furnace shall be provided with a 24 volt<sup>40%</sup> electronic modulating gas valve which provides for firing rates between 50% and 100%. ~~The valve is controlled by an electronic signal conditioner that uses a direct digital control signal of either 4-20 mA, or 0-10 Volts, provided by an external D.D.C. system.~~

MERV 13 .7

- .5 Spark-ignited, intermittent safety pilot with electronic flame supervision.
- .6 Filters: 50mm thick ~~MERV 14~~ pleated disposable, non woven cotton fabric media with metal support grid and heavy duty beverage board frame. Provide a factory installed differential pressure switch for indication of filter status wired to the control terminal board.

- ✓.8 Damper: 100% outside air damper with damper motor on/off, spring return closed electrically interlocked with supply fan contactor. Damper must open to 80% before the fan is allowed to operate. Construction The air control damper is low leak with blade and jamb seals. The damper air leakage will not exceed 10 cfm per square foot at 4" sp. The damper is constructed of 16 gage galvanized steel with reinforcement to insure structural integrity. Blade edge seals are PVC coated polyester fabric suitable for -25F to 180F -32C to 83C mechanically locked into the blade edge. Jamb seals are flexible stainless steel metal, compression type to prevent leakage between end of the blade and the damper frame. Bearings are corrosion resistant.
- ✓.9 Outside air screened inlet hood ~~with moisture eliminator louver.~~
- ✓.10 Basic operating controls:
  - .1 Motor contactors for all fans and compressors, overload protection , control circuit transformers, terminal blocks, grounding lugs, auxiliary contactors, terminals for connection of external devices, cooling relay, ambient compressor lockout, high pressure and automatic reset low pressure controls, head pressure actuated fan cycling, five minute anti-cycle timers, interstage time delay timers, hot gas bypass on lead compressor and single phase protection. Heating section to be provided with an automatic reset high temperature cut-out and combustion air flow proving switch. All operating controls to be enclosed in a panel to CSA requirements.
- ✓.11 Wiring, testing and certification: the unit to be equipped with CSA listed components, CGA certified and totally wired to requirements of the Canadian Electrical Code, Part 1, and pertinent sections of Part 2 relative to specific equipment type and purpose. All electrical circuitry to undergo dielectric strength tests to CSA C22.2-0.
- ✓.12 Temperature controls: Factory installed and tested application specific controller to provide the following sequences:
  - .1 Start/stop: A normally closed outdoor air damper to open on system start-up, and when fully open, interlocks initiate heating operation to satisfy ~~space temperature~~ Supply Air set point. Damper to return to closed position on power or system failure or on scheduled or manual shut-down.
- .13 Provide BACnet card and terminals for connection to remote EMCS panel to provide remote indication of supply air temperature, filter status, system on/off status, and heating on/off status and alarm signal for low limit failure. Also provide connections for EMCS capability for system on-off control and supply air temperature adjustment. Provide all required wiring diagrams to provide a working interface with the EMCS for all system status points as well as control.

BacNet  
MSTP  
Connection

	
<b>SHOP DRAWING REVIEW</b> PER M/E SPECIFICATIONS SECTIONS	
DATE	PROJECT No.
<b>2026/04/29</b>	<b>24333-08</b>
<input type="checkbox"/> NOT REVIEWED	<input checked="" type="checkbox"/> REVIEWED
<input type="checkbox"/> RESUBMIT	<input type="checkbox"/> REVIEWED AS MODIFIED
<input type="checkbox"/> NOT SPECIFIED BY MCW, REVIEWED FOR MEP ONLY	
ELECTRICAL REVIEWER:	MECHANICAL REVIEWER:
<u>R.A.</u>	<u>TT</u>



HTS Oshawa

2001 Thickson Rd, South  
Unit #11  
Whitby, ON L1N 6J3  
T 905.579.6700  
F 905.597.5290

[ontario.htseng.com](http://ontario.htseng.com)

SUBMITTAL DATA  
APPROVAL REQUIRED

# GAS FIRED MAKE UP AIR UNIT

## MAU-4500CFM – Make Up Air Unit

Note:

- 1.) Unit Location:
  - a) Roof
- 2.) Area Served:
  - a) Weld Shop #4
- 3.) Unit Electrical:
  - a) 575/3/60 electrical feed, 8.5MCA/15MOCP
    - i. Main Disconnect is Provided
- 4.) Unit complete with:
  - a) Outdoor air hood – pre-screens included
  - b) Supply Fan c/w VFD – Constant Volume – belt drive
  - c) Right Hand Access door – Consultant to confirm
  - d) Filter Rack – 2" MERV13
  - e) Gas Burner – 1 Modulating, 1 On/Off
  - f) 16" tall roof curb
  - g) Modulating Hot Gas Reheat coil for dehumidification
  - h) Natural Gas Burner – 20:1 turndown
- 5.) Controls:
  - a) Carel Controller – Discharge air control
  - b) BacNet MSTP connection for BAS
- 6.) Start Up:
  - a) Factory Start up - Assistance
- 7.) Warranty:
  - a) One (1) year parts warranty

	<b>SHOP DRAWING REVIEW</b>	
	PER M/E SPECIFICATIONS SECTIONS	
DATE	PROJECT No.	
<b>2026/04/29</b>	<b>24333-08</b>	
<input type="checkbox"/> NOT REVIEWED	<input checked="" type="checkbox"/> REVIEWED	
<input type="checkbox"/> RESUBMIT	<input type="checkbox"/> REVIEWED AS MODIFIED	
<input type="checkbox"/> NOT SPECIFIED BY MCW, REVIEWED FOR MEP ONLY		
ELECTRICAL REVIEWER:	MECHANICAL REVIEWER:	
<u>R.A.</u>	<u>TT</u>	





## SUBMITTAL SCHEDULE & DATA

### Indirect Gas-Fired Duct Furnace/Make-Up Air Units

Model	Description	Qty	Tag
HDP500TMRLN90G3HH2KDA00	Weatherproof Duct Furnace and Blower	1	MAU-4500CFM
	HDP500TMRLN90G3HH2KDA00	1	MAU-4500CFM
#76964	WIRING DIA 8H007007_____	1	MAU-4500CFM
#34659	Canadian External Serial Plate Kit	1	MAU-4500CFM
#32062	2 In MERV 13 Disposable Filters	1	MAU-4500CFM
#32641	Double Wall Blower Section	1	MAU-4500CFM
#32657	Double Wall Downturn Section	1	MAU-4500CFM
#31027	Supply Air Fire Stat	1	MAU-4500CFM
#31017	BACnet MS/TP Network Interface Card	1	MAU-4500CFM
#40452	Step Down Transformer, 575V, 500 VA	1	MAU-4500CFM
#25531	Sheave Setting 0.5 Turns Open	1	MAU-4500CFM
#32826	Dead-Front Non-Fusible Disconnect Switch	1	MAU-4500CFM
#31045	VFD Interface - Constant Speed	1	MAU-4500CFM
#31068	CNTRL-SUP FAN - CONSTANT SPEED ADJ	1	MAU-4500CFM
#24001	CNTRL-SUP FAN MIN OUTPUT HEAT=69%	1	MAU-4500CFM
#31075	CNTRL-DMPR-2 POS VIA OCCUPANCY	1	MAU-4500CFM
#31057	CNTRL-SA TEMP RESET - NONE	1	MAU-4500CFM
#76957	Factory Installed VFD - 5Hp, 575V/3, ATV320	1	MAU-4500CFM
31010	MCS Supply Air Temp Sensor	1	MAU-4500CFM
31009	MCS Outdoor Temp Sensor	1	MAU-4500CFM
32748	Rainhood with Birdscreen	1	MAU-4500CFM
40442	Insulated 16" Roof Curb	1	MAU-4500CFM
31016	Remote User Interface Module	1	MAU-4500CFM

 DATE <b>2026/04/29</b>	<b>SHOP DRAWING REVIEW</b> PER M/E SPECIFICATIONS SECTIONS PROJECT No. <b>24333-08</b>
<input type="checkbox"/> NOT REVIEWED	<input checked="" type="checkbox"/> REVIEWED
<input type="checkbox"/> RESUBMIT	<input type="checkbox"/> REVIEWED AS MODIFIED
<input type="checkbox"/> NOT SPECIFIED BY MCW, REVIEWED FOR MEP ONLY	
ELECTRICAL REVIEWER: <b>R.A.</b>	MECHANICAL REVIEWER: <b>TT</b>



## HDP MODEL NOMENCLATURE

Tag: MAU-4500CFM

1	2	3	4,5,6	7	8	9	10	11	12	13	14	15	16	17	18	19	20, 21	22	23
H	D	P	500	T	M	R	L	N	9	0	G	3	H	H	2	K	DA	0	0

**1 - Product Type (PT)**

H - Weatherproof Duct Furnace and Blower

**2 - Unit Configuration (UC)**

D - Downturn Package - Furnace, Blower, & Downturn

**3 - Venting (V)**

P - Power

**4,5,6 - Furnace Input Rating (MBH)**

500 - 500,000 Btu/Hr Input

**7 - Heat Exchanger/Burner/Drip Pan Material (HE)**

T - 409 Stainless Steel

**8 - Development Sequence Designation (DS)**

M - 2-stage or Modulating

**9 - Access Side (AS) (as viewed with air blowing toward you)**

R - Right Hand

**10 - Air Temperature Rise (ATR)**

Low - 20°-60°F (per furnace)

**11- Gas Type (GT)**

N - Natural with continuous retry ignition controller

**12 - Gas Valve (GV)**

9 - Electronic Modulation with Modine Control System

**13- Additional Safety Switches (SS)**

0 - No Additional Switches

**14 - Supply Voltage (SV)**

G - 575/60/3

**15 - Transformer (TR)**

3 - 150VA

**16- Blower Size & Bearing Type (BB)**

H - 15-15 Pillow Block Bearings

**17- Motor Horsepower (HP)**

H - 5 Hp

**18- Motor Type (MT)**

2 - ODP - High Eff.

**19 - Sheave Arrangement (SA)**

K - 184 Motor Frame Size, 934-1136 RPM Range

**20,21 - Air Control (AC)**

DA - FA Dampers w/2 Pos motor (No RA)

**22 - Evaporative Cooling (EC)**

0 - None

**23 - Cooling Coil (CC)**

0 - None

	<b>SHOP DRAWING REVIEW</b> PER M/E SPECIFICATIONS SECTIONS	
	DATE <b>2026/04/29</b>	PROJECT No. <b>24333-08</b>
<input type="checkbox"/> NOT REVIEWED	<input checked="" type="checkbox"/> REVIEWED	
<input type="checkbox"/> RESUBMIT	<input type="checkbox"/> REVIEWED AS MODIFIED	
<input type="checkbox"/> NOT SPECIFIED BY MCW, REVIEWED FOR MEP ONLY		
ELECTRICAL REVIEWER: <b>R.A.</b>	MECHANICAL REVIEWER: <b>TT</b>	



## GENERAL PERFORMANCE DATA

---

### General Performance Data

**Tag:** MAU-4500CFM  
**Model:** HDP500  
**At 0' Elevation**

---

Btu/Hr. Input	500,000
Btu/Hr. Output	405,000
Thermal Efficiency	81.0%
Discharge Air Temp (°F)	79.3
Configured Air Temp Rise (°F)	83.3
Configured Airflow	4,500

### As Configured at 0-2000 Ft. Elevation

---

Btu/Hr. Input	500,000
Btu/Hr. Output	405,000
Thermal Efficiency	81.0%
Discharge Air Temp (°F)	79.3
Configured Air Temp Rise (°F)	83.3
Configured Airflow	4,500

	<b>SHOP DRAWING REVIEW</b>	
	PER M/E SPECIFICATIONS SECTIONS	
DATE	PROJECT No.	
<b>2026/04/29</b>	<b>24333-08</b>	
<input type="checkbox"/> NOT REVIEWED	<input checked="" type="checkbox"/> REVIEWED	
<input type="checkbox"/> RESUBMIT	<input type="checkbox"/> REVIEWED AS MODIFIED	
<input type="checkbox"/> NOT SPECIFIED BY MCW, REVIEWED FOR MEP ONLY		
ELECTRICAL REVIEWER:	MECHANICAL REVIEWER:	
<u>R.A.</u>	<u>TT</u>	



## BUILDING MANAGEMENT SYSTEM VARIABLES<sup>1</sup>

### Indirect Gas-Fired Duct Furnace/Make-Up Air Units – Typical BACnet® Variables

Tag: MAU-4500CFM

#### ANALOG VARIABLES

Read/Write	Data Type	Variable Description	BACnet Variable Name	BACnet Address
R	A	Supply Air Temp	SA_Temp_BMS	AV1
R	A	Space Temp	pAD_Temp_BMS	AV2
R	A	Space Dew Point	pAD_DewP_BMS	AV3
R	A	Space Enthalpy	pAD_Enth_BMS	AV4
R	A	Outdoor Air Temp	OA_Temp_BMS	AV5
R	A	Outdoor Air Dew Point	OA_DewP_BMS	AV6
R	A	Outdoor Air Enthalpy	OA_Enth_BMS	AV7
R	A	Return Air Temp	RA_Temp_BMS	AV8
R	A	Return Air Dew Point	RA_DewP_BMS	AV9
R	A	Return Air Enthalpy	RA_Enth_BMS	AV10
R	A	Mixed Air Temp	MA_Temp_BMS	AV11
R	A	Mixed Air Dew Point	MA_DewP_BMS	AV12
R	A	Mixed Air Enthalpy	MA_Enth_BMS	AV13
R	A	Actual Supply Air Temp Setpoint	SA_SP_BMS	AV14
R/W	A	Occupied - Space Heating Setpoint	Space_Heat_SP_Occ_BMS	AV15
R/W	A	Occupied - Space Cooling Setpoint Offset	Space_Cool_Offset_Occ_BMS	AV16
R	A	Occupied - Space Cooling Setpoint	Space_Cool_SP_Occ_BMS	AV17
R/W	A	Occupied - Space Heating Differential	Space_Heat_Diff_Occ_BMS	AV18
R/W	A	Occupied - Space Cooling Differential	Space_Cool_Diff_Occ_BMS	AV19
R/W	A	Occupied - Supply Air Heating Setpoint	SA_Heat_Res_SP_Occ_BMS	AV20
R/W	A	Neutral Air Temp Setpoint	SA_NA_SP_BMS	AV21
R/W	A	Occupied - Supply Air Cooling Setpoint	SA_Cool_Res_SP_Occ_BMS	AV22
R/W	A	Unoccupied - Space Heating Setpoint	Space_Heat_SP_Unocc_BMS	AV23
R/W	A	Unoccupied - Space Cooling Setpoint	Space_Cool_SP_Unocc_BMS	AV24
R/W	A	Unoccupied - Space Heating Differential	Space_Heat_Diff_Unocc_BMS	AV25
R/W	A	Unoccupied - Space Cooling Differential	Space_Cool_Diff_Unocc_BMS	AV26
R/W	A	Unoccupied - Supply Air Heating Setpoint	SA_Heat_Res_SP_Unocc_BMS	AV27
R/W	A	Unoccupied - Supply Air Cooling Setpoint	SA_Cool_Res_SP_Unocc_BMS	AV28
R/W	A	Dehum Mode Supply Air Temp Setpoint	Dehum_SAT_Setpoint_BMS	AV29
R/W	A	55F (0-100)	SA_Reset_Heat_High_BMS	AV30
R/W	A	70F (50-100)	SA_Reset_Heat_Low_Cool_High_BMS	AV31
R/W	A	78F (50-100)	SA_Reset_Cool_Low_BMS	AV32
R/W	A	70F (50-100)	OA_Reset_Heat_Low_BMS	AV33
R/W	A	85F (50-100)	OA_Reset_Heat_High_BMS	AV34
R/W	A	30F (0-100)	OA_Reset_Cool_Low_BMS	AV35
R/W	A	60F (50-100)	OA_Reset_Cool_High_BMS	AV36
R/W	A	Outdoor Air Dew Point Setpoint	OA_DewP_SP_BMS	AV37
R/W	A	Mixed Air Dew Point Setpoint	MA_DewP_SP_BMS	AV38
R/W	A	Unoccupied - Dew Point Setpoint	Unocc_DewP_SP_BMS	AV39
R/W	A	pAD Wall Stat Minimum Allowed Temp Setpoint	pAD_SetMin_Temp_BMS	AV40
R/W	A	pAD Wall Stat Maximum Allowed Temp Setpoint	pAD_SetMax_Temp_BMS	AV41

(continued next page)

SHOWN AS REVIEWED  
 PER THE SPECIFICATIONS SECTIONS  
 DATE: 2026/04/29 PROJECT No. 24333-08

NOT REVIEWED                       REVIEWED  
 RESUBMIT                               REVIEWED AS MODIFIED  
 NOT SPECIFIED BY MCW, REVIEWED FOR MEP ONLY

ELECTRICAL REVIEWER: R.A.                      MECHANICAL REVIEWER: TT



## BUILDING MANAGEMENT SYSTEM VARIABLES<sup>1</sup>

### Indirect Gas-Fired Duct Furnace/Make-Up Air Units – Typical BACnet® Variables

Tag: MAU-4500CFM

#### ANALOG VARIABLES (continued)

Read/Write	Data Type	Variable Description	BACnet Variable Name	BACnet Address
R/W	A	SA Exit Fan Only Enter Heating Offset	SA_Vent_Mode_Heating_Offset_BMS	AV42
R/W	A	SA Exit Fan Only Enter Cooling Offset	SA_Vent_Mode_Cooling_Offset_BMS	AV43
R	A	SA Heating Changeover Temp	SA_Vent_Mode_Heating_CO_Temp_BMS	AV44
R	A	SA Cooling Changeover Temp	SA_Vent_Mode_Cooling_CO_Temp_BMS	AV45
R/W	A	Supply Fan Speed Setpoint	SF_Speed_SP_BMS	AV46
R/W	A	Exhaust Fan Speed Setpoint	EF_Speed_SP_BMS	AV47
R/W	A	DX Cooling Outdoor Air Temp Lockout Setpoint	DX_Cooling_Lockout_Temp_BMS	AV48
R/W	A	CW Cooling Outdoor Air Temp Lockout Setpoint	CW_Cooling_Lockout_Temp_BMS	AV49
R/W	A	Outdoor Air Fill Setpoint For Evaporative Cooling	Evap_Cool_OA_Enable_Setp_BMS	AV50
R/W	A	Outdoor Air Freeze Protection Setpoint To Drain Evaporative Cooler	Evap_Cool_Freeze_OA_Setp_BMS	AV51

#### INTEGER VARIABLES

Read/Write	Data Type	Variable Description	BACnet Variable Name	BACnet Address
R	I	Description of values in Controls Manual	Unit_Status	AV1001
R	I	Description of values in Controls Manual	Occupancy_Status	AV1002
R	I	Description of values in Controls Manual	Unit_Mode	AV1003
R	I	Description of values in Controls Manual	Mechanical_Temp_Lockouts	AV1004
R	I	Space Humidity	pAD_Hum	AV1005
R	I	Outdoor Air Humidity	Outdoor_Air_Humidity	AV1006
R	I	Return Air Humidity	Return_Air_Humidity	AV1007
R	I	Mixed Air Humidity	Mixed_Air_Humidity	AV1008
R	I	Duct Pressure	Duct_Pressure	AV1009
R	I	Building Pressure	Building_Pressure	AV1010
R	I	Space CO2 Content	Space_CO2_Content	AV1011
R	I	Modulating Cooling Demand	Aout_Cooling_Signal_Dispatch	AV1012
R	I	Modulating Furnace Demand	Aout_Furnace_1_Signal_Dispatch	AV1013
R	I	Outdoor Air Damper Position	OA_Damper	AV1014
R	I	Return Air Damper Position	RA_Damper	AV1015
R	I	Blower Speed Demand	Aout_Blower_Speed_Dispatch	AV1016
R	I	Exhaust Fan Speed Demand	Aout_Exhaust_Fan_Speed_Dispatch	AV1017
R	I	Heating Demand	Heating_Demand_Dispatch	AV1018
R	I	Cooling Demand	Cooling_Demand_Dispatch	AV1019
R	I	Supply Air Dehum Demand	Dehum_Demand_Dispatch	AV1020
R/W	I	pAD Wall Set Minimum Allowed rH Setpoint	pAD_SetMin_Hum_BMS	AV1021
R/W	I	pAD Wall Set Maximum Allowed rH Setpoint	pAD_SetMax_Hum_BMS	AV1022
R/W	I	Occupied - Space rH Setpoint	Occ_DeHum_Space_rH_SP_BMS	AV1023
R/W	I	Unoccupied - Space rH Setpoint	Unocc_DeHum_Space_rH_SP_BMS	AV1024
R/W	I	Space CO2 Setpoint	Space_CO2_Setp	AV1025
R/W	I	Outdoor Air Minimum Open Position	OA_Damper_Min_Pos_BMS	AV1026
R/W	I	Outdoor Air Maximum Open Position	OA_Damper_Max_Pos_BMS	AV1027
R/W	I	Outdoor Air Damper Open Position	OA_Damper_Pos_BMS	AV1028

(continued next page)

STOP DRAWING REVIEW  
PER M/E SPECIFICATIONS SECTIONS  
PROJECT NO. 24333-08  
DATE 2026/04/29

NOT SPECIFIED BY MCW, REVIEWED FOR MEP ONLY  
 NOT REVIEWED       REVIEWED  
 REVIEWED AS MODIFIED

ELECTRICAL REVIEWER: R.A. \_\_\_\_\_      MECHANICAL REVIEWER: T.G. \_\_\_\_\_







## BUILDING MANAGEMENT SYSTEM VARIABLES<sup>1</sup>

### Indirect Gas-Fired Duct Furnace/Make-Up Air Units – Typical BACnet® Variables

Tag: MAU-4500CFM

#### DIGITAL VARIABLES (continued)

Read/Write	Data Type	Variable Description	BACnet Variable Name	BACnet Address
R	D	SA RA Fire Stat Smoke Detector - Shutdown Unit, Auto Reset	Sup_Ret_Air_Smoke_Auto	BV69
R	D	SA RA Fire Stat Smoke Detector - Shutdown Unit, Manual Reset	Sup_Ret_Air_Smoke_Manual	BV70
R	D	Faulty Supply Air Temp Sensor - Shutdown Unit	SAT_Sensor_Fail_Unit_Shutdown	BV71
R	D	Supply Duct Pressure Probe Fault - Shutdown Unit	Duct_Press_Fail_Unit_Shutdown	BV72
R	D	High Supply Duct Pressure - Shutdown Unit	High_Duct_Press_Unit_Shutdown	BV73
R	D	DX Condensing Unit Alarm	Condensing_Unit_Alarm	BV74
R	D	Evaporative Cooler Freeze Alarm	AL_Evap_CL_OAT_Freeze_Alarm	BV75
R	D	Sustained Low Supply Air Temp - Shutdown Unit	Low_SAT_Unit_Shutdown	BV76
R	D	Sustained High Supply Air Temp - Shutdown Unit	High_SAT_Unit_Shutdown	BV77
R	D	Cooling Locked Out	Cooling_Lockout	BV78
R	D	Furnace Heat Locked Out Due To High OAT	Furnace_Heating_Temp_Lockout	BV79

Points shown are typical for BACnet® interfaced units. Depending on how the unit was configured, some R/W points may not be writable. Contact Modine for further guidance as necessary.

**SHOP DRAWING REVIEW**  
PER M/E SPECIFICATIONS SECTIONS

DATE: **2026/04/29**      PROJECT No.: **24333-08**

NOT REVIEWED                       REVIEWED  
 RESUBMIT                               REVIEWED AS MODIFIED  
 NOT SPECIFIED BY MCW, REVIEWED FOR MEP ONLY

ELECTRICAL REVIEWER: R.A.                      MECHANICAL REVIEWER: TT



## DIMENSIONS – UNIT

### Model HDP500 Dimensions - Blower Type (Digit 16) = H

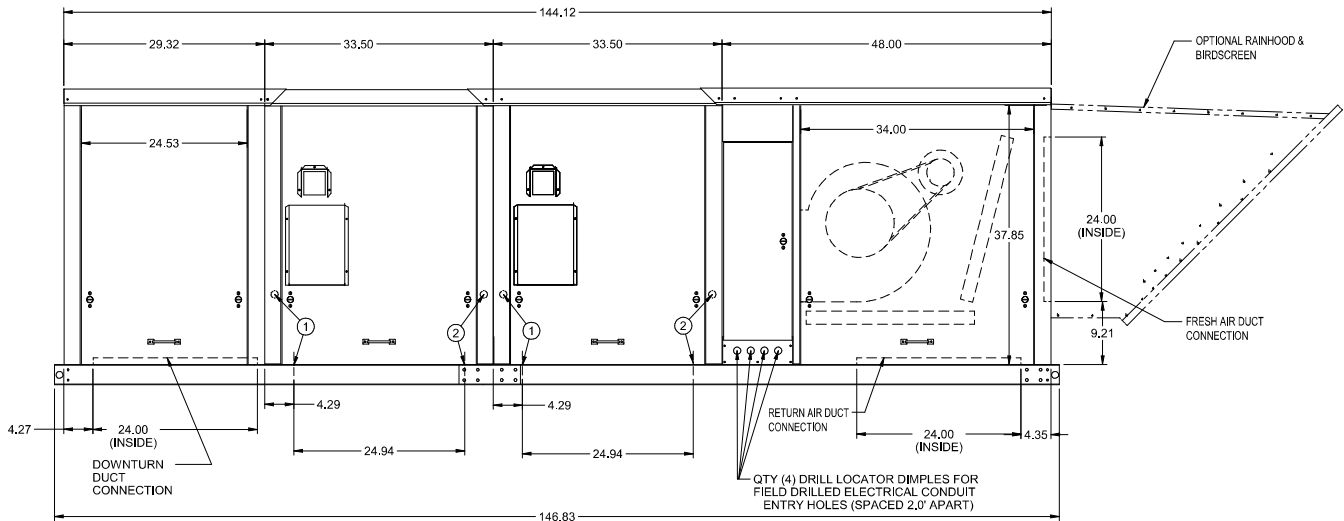

**mcw** SHOP DRAWING REVIEW  
PER M/E SPECIFICATIONS SECTIONS

DATE: **2026/04/29** PROJECT No.: **24333-08**

NOT REVIEWED       REVIEWED

RESUBMIT             REVIEWED AS MODIFIED

NOT SPECIFIED BY MCW, REVIEWED FOR MEP ONLY

ELECTRICAL REVIEWER: **R.A.**      MECHANICAL REVIEWER: **TT**

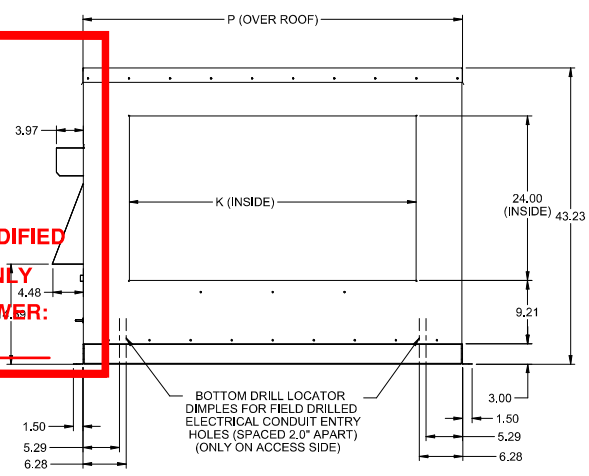

Tag: **MAU-4500CFM**

Dimensions (inches)	
K	29.96
P	44.05
Gas Connection	3/4"

- Notes:
- For Right Hand Access Units – Location of drill locator dimples for gas pipe entry– one on side of unit and one on bottom.
  - For Left Hand Access Units – Location of drill locator dimples for gas pipe entry– one on side of unit and one on bottom.
  - This is a general submittal drawing showing a right hand access unit. Left hand access units are mirrored except for the furnaces which are rotated from what is shown.
  - This is a general submittal drawing showing location of return air which may or may not be included on the unit. Please refer to the Submittal Schedule and Model Nomenclature pages for additional information.



AccuSpec V4.67a

## DIMENSIONS – UNIT BASE

Unit Base Dimensions, Model HDP500 - Blower Type (Digit 16) = H

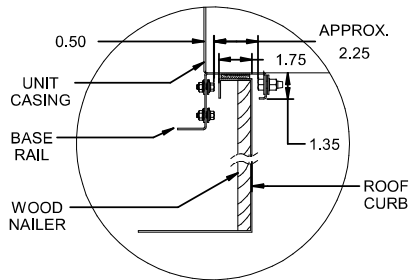

	SHOP DRAWING REVIEW	
	PER M/E SPECIFICATIONS SECTIONS	
DATE	PROJECT No.	
<b>2026/04/29</b>	<b>24333-08</b>	
<input type="checkbox"/> NOT REVIEWED	<input checked="" type="checkbox"/> REVIEWED	
<input type="checkbox"/> RESUBMIT	<input type="checkbox"/> REVIEWED AS MODIFIED	
<input type="checkbox"/> NOT SPECIFIED BY MCW, REVIEWED FOR MEP ONLY		
ELECTRICAL REVIEWER:	MECHANICAL REVIEWER:	
<u>R.A.</u>	<u>TT</u>	

Tag: **MAU-4500CFM**  
 Dimensions (inches)

A	146.77	H	1.53
B	46.75	J	43.89
C	144.12	E <sup>1</sup>	29.46
F	78.66	M <sup>1</sup>	7.21
G	53.72	Pipe Conn.	3/4"

**Note 1:** This is a general submittal drawing showing location of return air which may or may not be included on the unit. Please refer to the Submittal Schedule and Model Nomenclature pages for additional information.



AccuSpec V4.67a

## DIMENSIONS – ROOF CURB

### Roof Curb Dimensions, Model HDP500 - Blower Type (Digit 16) = H

	<b>SHOP DRAWING REVIEW</b>	
	PER M/E SPECIFICATIONS SECTIONS	
DATE	PROJECT No.	
<b>2026/04/29</b>	<b>24333-08</b>	
<input type="checkbox"/> NOT REVIEWED	<input checked="" type="checkbox"/> REVIEWED	
<input type="checkbox"/> RESUBMIT	<input type="checkbox"/> REVIEWED AS MODIFIED	
<input type="checkbox"/> NOT SPECIFIED BY MCW, REVIEWED FOR MEP ONLY		
ELECTRICAL REVIEWER:	MECHANICAL REVIEWER:	
<u>R.A.</u>	<u>TT</u>	

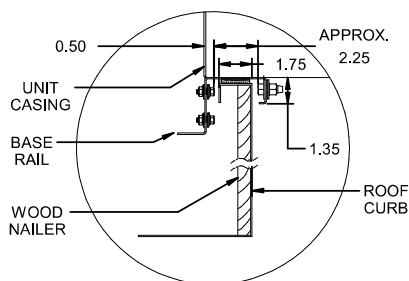

**Tag: MAU-4500CFM**  
**Dimensions (inches)**

A	151.1	F	39.25
B	139.1	G	4.96
C	105.98	H <sup>1</sup>	29.46
D	33.12	J	74.84
E	51.25	Ship Weight (lbs.)	316

**Note 1:** This is a general submittal drawing showing location of return air which may or may not be included on the unit. Please refer to the Submittal Schedule and Model Nomenclature pages for additional information.



AccuSpec V4.67a

## DIMENSIONS – RAINHOOD & BIRDSCREEN

### Rainhood and Birdscreen Dimensions

Rainhood and Birdscreen Dimensions  
(All dimensions in inches)

Tag:	MAU-4500CFM
Model Size	HDP500
Dimensions	

---

A	41.34
---	-------

	<b>SHOP DRAWING REVIEW</b>	
	PER M/E SPECIFICATIONS SECTIONS	
DATE	PROJECT No.	
<b>2026/04/29</b>	<b>24333-08</b>	
<input type="checkbox"/> NOT REVIEWED	<input checked="" type="checkbox"/> REVIEWED	
<input type="checkbox"/> RESUBMIT	<input type="checkbox"/> REVIEWED AS MODIFIED	
<input type="checkbox"/> NOT SPECIFIED BY MCW, REVIEWED FOR MEP ONLY		
ELECTRICAL REVIEWER:	MECHANICAL REVIEWER:	
<u>R.A.</u>	<u>TT</u>	



AccuSpec V4.67a

## BLOWER CURVE

### Indirect Gas-Fired Duct Furnace/Make-Up Air Units

Tag: MAU-4500CFM

Model Number	HDP500TMRLN90G3HH2KDA00
Airflow (CFM)	4,500
Altitude (ft. ASL)	0-2000
External Static Pressure ("W.C.)	1.50
Total Static Pressure ("W.C.)	2.07
Blower Size - RPM	H - 15-15 Pillow Block Bearings - 1,123 RPM
Motor Size - RPM	5 HP - 1800 RPM
Sheave Adjustment Range (RPM)	934-1136

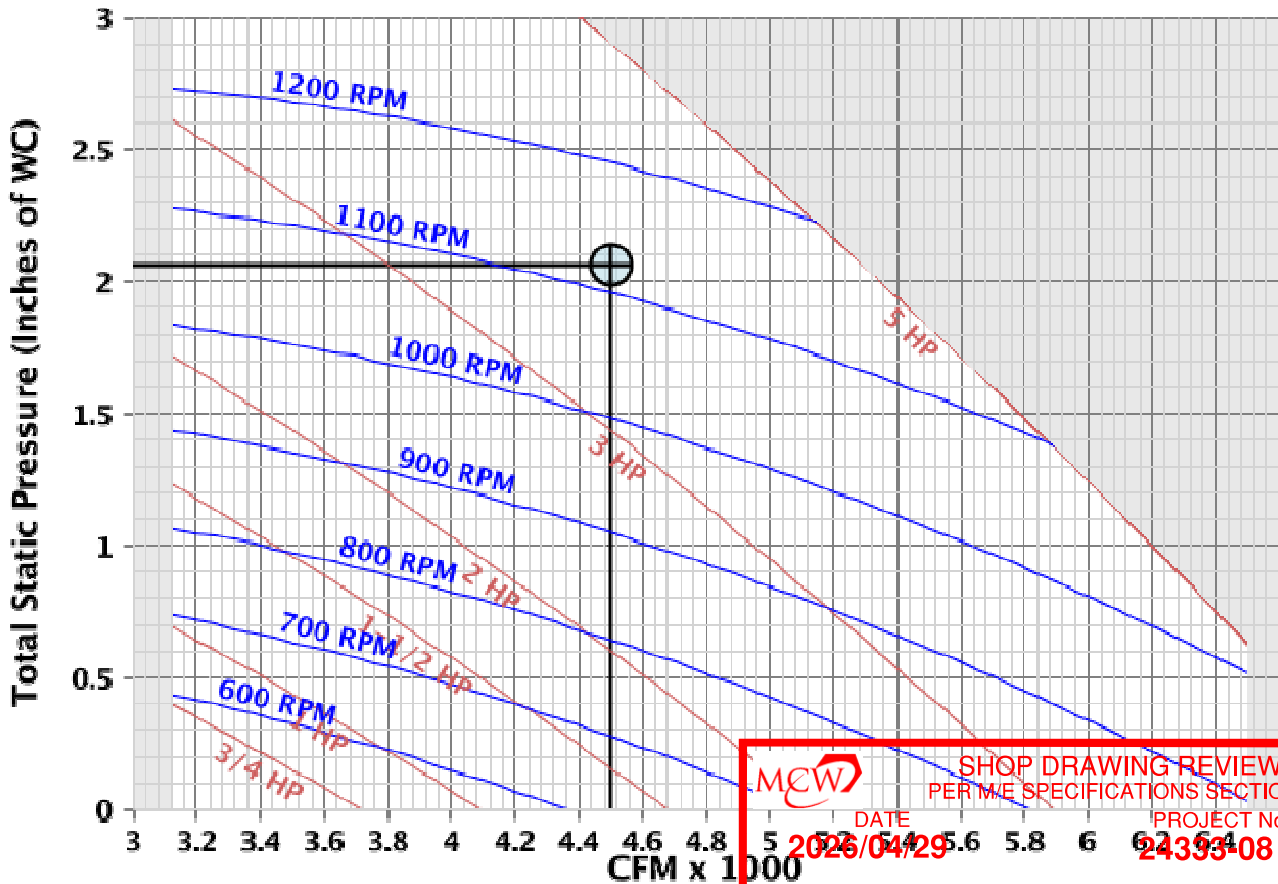

**mcw** SHOP DRAWING REVIEW  
PER THE SPECIFICATIONS SECTIONS

DATE: 2026/04/29 PROJECT No. 24333-08

NOT REVIEWED                       REVIEWED  
 RESUBMIT                             REVIEWED AS MODIFIED  
 NOT SPECIFIED BY MCW, REVIEWED FOR MEP ONLY

ELECTRICAL REVIEWER: R.A.                      MECHANICAL REVIEWER: TT

**SPECIFICATIONS**

Tag: MAU-4500CFM

**GENERAL**

**SUMMARY**

This Section includes indirect gas-fired heating or heating/make-up air units. Each unit shall be constructed in a horizontal configuration and shall incorporate additional product requirements as listed in the "PRODUCTS" section of this specification. If unit is intended for installation on a concrete slab, verify design requirements and construction responsibility for the slab.

**SUBMITTALS**

All information in this document, as provided by Modine Manufacturing Company, is provided without representation or warranty of any kind as to the user or any other party, including, without limitation, ANY IMPLIED WARRANTY OF MERCHANTABILITY, FITNESS FOR PARTICULAR PURPOSE, OR NON-INFRINGEMENT. To the greatest extent permitted by applicable law, Modine Manufacturing Company assumes no liability, and the user assumes all liability and risk, for the use or results from the use of this document or the information contained herein, whether as modified by the user or not. This document must be carefully reviewed by the Engineer to ensure it meets the requirements of the project and local building code(s).

As Modine Manufacturing Company has a Continuous Product Improvement program, it reserves the right to change design and specifications without notice.

**QUALITY ASSURANCE**

The duct furnace(s) shall include ETL design certification for use in both the US and Canada to the ANSI Z83.8 - latest revision, standard for "Gas Unit Heater and Gas-Fired Duct Furnaces" for safe operation, construction, and performance.

The complete system featuring duct furnace(s) and blower section (and cooling and downturn sections if applicable) shall include ETL design certification and the unit nameplate shall include the ETL/ETL Canada listed mark for use in both the US and Canada and must conform to UL 60335-2-40:2022 Ed.4 and be certified to CSA C22.2#60335-2-40:2022 Ed.4 "Household and Similar Electrical Appliances - Safety - Part 2 - 40: Particular Requirements for Electrical Heat Pumps, Air-Conditioners, and Dehumidifiers". This includes UL 60335-1 and CSA C22.2#60335-1 "Household and Similar Electrical Appliances - Part 1: General Requirements".

Manufacturer Qualifications: Company specializing in manufacturing the products specified in this section with minimum ten years documented experience.

**PRODUCTS**

**GENERAL**

Furnish and install an indirect gas-fired heating or heating/make-up air unit. Unit shall be fully assembled, wired, and tested prior to shipment. If unit is intended for installation on a concrete slab, verify design requirements and construction responsibility for the slab.

**MANUFACTURERS**

The basis-of-design product for the indirect gas-fired heating or heating/make-up air unit is based on the Modine model HDP.

**MECHANICAL CONFIGURATION**

Unit(s) shall have right side access, when looking into the discharge, and include:

Furnace section(s) controls.

Blower section containing a supply blower and motor with bottom support to provide rigidity. The blower connection shall be flexible with 1/4" gasket to prevent sound transmission into the supply ductwork.

Electrical section isolated from the supply air stream including a hinged access door. Separate conduit entry points shall be provided for both high and low voltage electrical connections. Provisions must be included for side access electrical connections for slab mounted units and bottom electrical connections for roof curb mounted units.

Downturn plenum section for downward deflection of the supply air.

**CABINET**

Duct Furnace

The duct furnace unit casing shall be constructed of not less than 18 gauge aluminized steel and shall be painted with a baked-on gray-green polyester powder paint (7 mil thickness) for corrosion resistance.

All duct furnace access side doors shall have heavy duty, draw tight, quarter turn latches.

Blower Section

The blower section shall be constructed of not less than 18 gauge aluminized steel and shall be painted with a baked-on gray-green polyester powder paint (7mil thickness) for corrosion resistance.

All blower section access side doors shall have heavy duty, draw tight, quarter turn latches.

The blower cabinet shall be insulated as noted below.

The blower cabinet shall include double wall construction as noted below.

Downturn Plenum Section

**SHOP DRAWING REVIEW**  
 PER M/E SPECIFICATIONS SECTIONS  
 2026/04/29  
 24333-08

NOT REVIEWED       REVIEWED  
 BELOW       REVIEWED AS MODIFIED  
 NOT SPECIFIED BY MCW, REVIEWED FOR MEP ONLY

**ELECTRICAL REVIEWER:** R.A.  
**MECHANICAL REVIEWER:** TT

The downturn plenum section shall be constructed of not less than 18 gauge aluminized steel and shall be painted with a baked-on gray-green polyester powder paint (7mil thickness) for corrosion resistance. All downturn plenum section access side doors shall have heavy duty, draw tight, quarter turn latches. The downturn cabinet shall be insulated as noted below. The downturn cabinet shall include double wall construction as noted below.

**Insulation**

Insulation shall be 1 inch, 1½ lb density acoustical and thermal insulation. The insulation shall be made of glass fibers bonded with a thermosetting resin and overlaid with a fire-resistant black acrylic coating for additional strength. The acrylic coating must meet the requirements of ASTM C 665 for fungi resistance. Double wall construction shall include a 22 gauge aluminized steel liner that covers the insulation to comply with ASHRAE 62.1 to prevent mold growth, allow easy cleaning, and protection of the insulation from the airstream and from entering the airstream.

**Other Construction**

Roof shall be designed for maximum roof rigidity and prevention of standing water and perimeter drip edges to prevent water from dripping into the access doors. Unit shall be designed to reduce air leakage and infiltration through the cabinet. Continuous gasket sealing shall be included between panels and between access doors and openings to reduce air leakage. The unit shall be provided with a 14 gauge, galvanized steel mounting base with lifting and anchoring holes. The base is designed for either curb or slab mounting. Unit shall include an inlet hood with screen that shall be pre-assembled from the factory and provided with internal baffles to prevent water entrainment in the supply air stream.

**AIR CONTROL CONFIGURATION**

Unit airflow control configuration shall be fresh air dampers with no return air opening for 100% outside air applications. The actuator shall be two-position. All fresh air dampers are ultra-low-leak with self-compensating stainless steel side seals and galvanized steel blades with edge seals. Dampers shall have a maximum Class I leakage resistance (less than 4 CFM/ft² at 1" W.C.) when tested in accordance with AMCA Standard No. 500, Test Methods for Louvers, Dampers, and Shutters. The damper actuator shall be mounted directly to the shaft of the fresh air damper. If return air dampers are provided, a damper linkage rod shall be provided to set the positions of the opposed dampers. As one damper opens, the opposing damper closes. The damper actuator shall be on-off, spring return so when power is disconnected, the damper closes the outside air opening. The damper actuator shall have one normally open and one normally closed end switch to prove that the damper has opened. Damper controls shall be as outlined in the "CONTROLS" section.

**HEATING SYSTEM**

The unit shall have an indirect fired gas heating section. The gas heat section shall consist of two single furnaces in series. Each furnace rating is 1/2 the total heat rating of the unit. The venting shall be a power exhausted arrangement. The unit shall be tested to insure proper ignition when the unit is subjected to 40 mile per hour wind velocities. A step down transformer from 575V supply voltage to 115V shall be provided for operation of the power exhauster motor. The gas heating section shall be configured for use with Natural Gas. The inlet gas pressure shall be 6-7" W.C. minimum, not to exceed 14" W.C. The thermal efficiency of the section shall be a minimum of 81% for all air flow ranges resulting in a temperature rise range of 20°F-60°F. The heat exchanger(s) shall be made of 20 gauge 409 stainless steel tubes and headers. The flue collector box shall be made of 20 gauge aluminized steel. The burner(s) shall be made of the same material as the heat exchanger with a thickness of not less than 28 gauge. Burner(s) shall have non-clogging, slotted ports with a stainless steel separator strip designed for good lighting characteristics without noise of extinction. The burner(s) shall be flame-fired. The heat exchanger tube shall be contoured and dimpled to provide efficient heat transfer and crimped to allow for thermal expansion and contraction. The heat exchanger(s) seams and duct connections shall be certified to withstand 3.0" W.C. external static pressure without burner flame disturbance.

located for service removal with  
PER M/E SPECIFICATIONS SECTIONS  
PROJECT No. 24333-08  
DATE 2026/04/29  
 NOT REVIEWED  REVIEWED  
 RESUBMIT  REVIEWED AS MODIFIED  
 NOT SPECIFIED BY MCW, REVIEWED FOR MEP ONLY  
ELECTRICAL REVIEWER: R.A. MECHANICAL REVIEWER: TT

The bottom of the unit shall be angled for draining any condensation to the corners of the unit. The condensation shall be removed through openings in the bottom pan.  
 The drain pan shall be constructed of 20 gauge 409 stainless steel.  
 The gas manifold(s) piping shall allow for gas piping connection on the side of the unit for slab mounted units and through the unit bottom for roof curb mounted units. The manifold(s) shall include a ground joint union for ease of servicing of the orifices without removing the burner assembly or main gas valve string.  
 Gas connections to the furnaces shall consist of individually piped manifolds with separate gas valves and separate ignition controllers.  
 A 1/8" manifold pressure tap shall be located after all valves to test the manifold pressure directly before the main burner orifices.  
 The orifices provided may include adjustable air shutters for controlling the primary air mixture.  
 Orifices shall be sized for operation at 0-2000 feet elevation above sea level.  
 The unit shall be provided with a single phase gas control transformer to step down the supply voltage to 24V.

The ignition controller(s) shall be 100% shut-off with continuous retry for natural gas.  
 The solid state ignition system shall intermittently light the pilot each time the system is energized. Once the pilot is proven, the main gas valve shall open and allow gas flow to the main burner.  
 Each furnace shall include an automatic reset high limit switch.  
 The unit shall include an air flow proving switch to insure air flow across the heat exchanger before allowing the gas controls to be energized.  
 The unit gas controls shall be provided with the following:  
 An electronic modulating gas valve and combination gas valve on the primary furnace and two-stage combination gas valves on successive furnace(s), ignition control on each furnace, and modulating control from the unit mounted microprocessor controller as described in the "Temperature Controls" section of "CONTROLS".  
 The gas controls can modulate the capacity of a single furnace from 40 to 100% of full fire, but by locking out a furnace, turndown is further reduced to 20% as a system.

**SUPPLY AIR BLOWER AND MOTOR**

The unit shall contain a single supply blower that is supported from the bottom to prevent the blower flanges supporting the weight of the motor. The blower shall be a double width, double inlet (DWDI) forward curved, belt driven assembly.  
 The blower shall have heavy duty, pillow block ball bearings.  
 The blower assembly shall include motor and blower vibration isolation using rubber-in-shear grommets.  
 The blower motor shall meet the following requirements:  
 The motor type shall be Open Drip Proof (ODP).  
 The motor shall be premium efficiency to meet the Energy Independence and Security Act requirements.  
 The motor shall be rated for 575/60/3Ph supply voltage.  
 The motor bearings shall be ball bearings rated for 200,000 hours. Motors not marked as having permanently lubricated bearings will include grease fittings for periodic lubrication.  
 The motor shall be inverter duty rated.  
 The motor wiring shall be in flexible metal BX conduit.  
 The motor shall be provided with an adjustable motor sheave to allow for minor adjustment of the blower rpm at the job site.  
 The motor shall be controlled by a factory installed variable frequency drive.  
 Supply air blower controls shall be as outlined in the "CONTROLS" section.

**FILTERS**

Filter Rating: Filters shall be pleated disposable filters with a Minimum Efficiency Reporting Value of MERV 13 per ASHRAE standard 52.2.

**ELECTRICAL**

The unit shall have an electrical control center where all high and low voltage connections are made.  
 All electrical components shall carry UL, ETL, or CSA listing.  
 The unit shall have a job specific wiring diagram affixed to the interior of the control compartment access door.

Unit shall have single point power lugs to land the power feed coming from a single power source.  
 Separate line voltage and low voltage terminal strips shall be provided. All terminal blocks and wires shall be individually numbered.  
 All electrical wires in the control panel shall be run in an enclosed raceway.  
 A single step down transformer shall be provided for all unit controls.  
 The unit shall be supplied with a factory installed non-fusible dead-front disconnect switch to disconnect power to the unit for servicing.

**CONTROLS**

<b>SHOP DRAWING REVIEW</b>	
PER M/E SPECIFICATIONS SECTIONS	
DATE <b>2026/04/29</b>	PROJECT No. <b>24333-08</b>
<input type="checkbox"/> NOT REVIEWED	<input checked="" type="checkbox"/> REVIEWED
<input type="checkbox"/> RESUBMIT	<input type="checkbox"/> REVIEWED AS MODIFIED
<input type="checkbox"/> NOT SPECIFIED BY MCW, REVIEWED FOR MEP ONLY	
<b>ELECTRICAL REVIEWER:</b> <u>R.A.</u>	<b>MECHANICAL REVIEWER:</b> <u>TT</u>

The unit shall include a Carel programmable microprocessor controller mounted in a controls compartment outside the airstream. The controller will be programmed with the Modine Controls System(TM) to operate the unit in an energy efficient manner using pre-engineered control strategies. The controller will monitor output from sensors within each unit subsystem and automatically adjust unit operating parameters to maintain programmed setpoints and strategies.

The control system shall contain LED's and/or LCD interface to indicate the power status, communications status, and fault conditions that arise during operation. Fault conditions indicated include but are not limited to supply air sensor failure, outdoor air sensor failure, space sensor failure, mechanical cooling failure, mechanical heating failure, low supply temperature alarm, high supply temperature alarm, and control temperature cooling or heating failure. The controller shall also monitor outside temperature for heating and cooling circuit lockout during mild conditions. If temperatures fall below the low supply temp alarm point, the unit shall be shut down.

The Carel controller shall be capable of independent stand-alone operation with field configuration, setpoint adjustment, and scheduling accomplished at the unit with an integral user interface that includes a backlit LCD display, keypad, and status LEDs to allow the programming of the control parameters (set point, differential band, alarm thresholds) and basic functions by the user (ON/OFF and display of the controlled values).

Remote Control User Interface: The unit shall be provided with a Carel model pDG1 hand-held user interface for the factory Microprocessor Controller. The device features a backlit LCD display and keyboard that displays status of controllers inputs and outputs, allows for unoccupied/occupied set-point changes, displays service settings, allows adjustment of control parameters, and is used for troubleshooting the unit. The device shall be field wired to the unit microprocessor controller via the Carel pLAN network using shielded cable by others.

The controller shall have a full calendar schedule for occupied, unoccupied, and holiday scheduling.

The controller shall retain all programmed values in non-volatile memory in the event of a power failure.

The Carel controller shall include a pCONet interface to provide the ability to communicate and integrate with BACNet® MS/TP communication networks.

Damper Controls: The damper controls subsystem shall be controlled by the microprocessor controller as follows:

The damper control shall be 2-position where the fresh air damper opens to 100% outside air when occupied. The fresh air damper closes when the unit is unoccupied or off.

Supply Fan Controls: The supply fan controls subsystem shall be controlled by the microprocessor controller as follows:

The supply fan shall be single speed with variable frequency drive. The fan speed can be adjusted manually, within design limits, from within the Modine Control System.

Temperature Controls: The temperature controls subsystem shall be controlled by the microprocessor controller as follows:

Supply Air Temperature Control – The Carel controller shall monitor and control the supply air temperature to maintain the desired supply air temperature.

The microprocessor controller shall monitor the following sensors to achieve the control strategy described above:

An outside air temperature only sensor shall be shipped loose for field installation in the outdoor environment.

A supply air temperature only sensor shall be shipped loose for field installation in the supply air ductwork, downstream from the unit discharge to ensure sensing of properly mixed airflow.

Other Optional Controls: The unit shall be provided with the following additional controls:

A manual reset supply air fire stat shall shut the system down if the temperature at the limit switch location exceeds 200°F.

**ROOF CURB**

Roof Curb: The unit shall be supplied with a knocked down, field assembled and installed roof curb.

Construction: The curb shall be 16" high to meet the National Roofing Contractors Association requirements. The curb shall be constructed of 16 gauge galvanized steel and include wood nailing strips and assembly hardware.

Insulation: The roof curb shall be fully insulated with 1 inch, 1 lb density acoustical and thermal insulation. The insulation shall be made of glass fibers bonded with a thermosetting resin and overlaid with a fire-resistant black acrylic coating for additional strength. The acrylic coating must meet the requirements of ASTM C 665 for fungal resistance.

Gasketing: Curb gasketing shall be furnished with the curb and is to be affixed to the curb immediately before mounting of the rooftop unit to provide an air seal.

Installation: The curb shall be designed for installation on a flat, non-sloped roof.

SHOP DRAWING REVIEW  
PER M/E SPECIFICATIONS SECTIONS  
DATE: 2026/04/29 PROJECT NO: 24333-08

NOT REVIEWED  REVIEWED

RESUBMIT  REVIEWED AS MODIFIED

NOT SPECIFIED BY MCW, REVIEWED FOR MEP ONLY

ELECTRICAL REVIEWER: R.A. MECHANICAL REVIEWER: TT



HTS Oshawa

2001 Thickson Rd, South  
Unit #11  
Whitby, ON L1N 6J3  
T 905.579.6700  
F 905.597.5290  
[ontario.htseng.com](http://ontario.htseng.com)

SUBMITTAL DATA  
APPROVAL REQUIRED

# INSTALLATION AND OPERATION MANUALS

	<b>SHOP DRAWING REVIEW</b>	
	PER M/E SPECIFICATIONS SECTIONS	
DATE	PROJECT No.	
<b>2026/04/29</b>	<b>24333-08</b>	
<input type="checkbox"/> NOT REVIEWED	<input checked="" type="checkbox"/> REVIEWED	
<input type="checkbox"/> RESUBMIT	<input type="checkbox"/> REVIEWED AS MODIFIED	
<input type="checkbox"/> NOT SPECIFIED BY MCW, REVIEWED FOR MEP ONLY		
ELECTRICAL REVIEWER:	MECHANICAL REVIEWER:	
<u>R.A.</u>	<u>TT</u>	



5-572.15

5H0762330001

October, 2025

# INSTALLATION AND SERVICE MANUAL indirect gas weatherproof make-up air units models HBP/ICP/HDP/HPP ORP/OCP/ODP/OPP

SHOP DRAWING REVIEW  
DATE: 2026/04/29  
PROJECT No: 24383-08

NOT REVIEWED  REVIEWED  
 RESUBMIT  REVIEWED AS MODIFIED  
 NOT SPECIFIED BY MCW, REVIEWED FOR MEP ONLY

ELECTRICAL REVIEWER: R.A.  
MECHANICAL REVIEWER: [Signature]



Intertek

All models approved for use in California by the CEC.

## ⚠ WARNING

1. Improper installation, adjustment, alteration, service or maintenance can cause property damage, injury or death, and could cause exposure to substances which have been determined by various state agencies to cause cancer, birth defects or other reproductive harm. Read the installation, operating and maintenance instructions thoroughly before installing or servicing this equipment.
2. To prevent premature heat exchanger failure, do not locate ANY gas-fired appliances in areas where corrosive vapors (i.e. chlorinated, halogenated or acid) are present in the atmosphere.

## ⚠ AVERTISSEMENT

1. Une installation, un réglage, une altération, une réparation ou une maintenance impropre risque de causer des dommages, des blessures ou la mort, et d'engendrer une exposition à des substances dont certains États ont déterminé qu'elles étaient cancérigènes ou pouvaient causer des malformations à la naissance et des problèmes de reproduction. Lisez bien les instructions d'installation, d'utilisation et de maintenance avant d'installer ou de réparer cet appareil.
2. Pour éviter la panne prématurée de l'échangeur thermique, ne placez AUCUN appareil à gaz à des endroits où les vapeurs corrosives (chlorées, halogénées ou acides) sont présentes dans l'atmosphère.

## FOR YOUR SAFETY

### IF YOU SMELL GAS:

1. Open windows.
2. Do not try to light any appliance.
3. Don't touch electrical switches.
4. Extinguish any open flame.
5. Immediately call your gas supplier.

## POUR VOTRE SÉCURITÉ

### SI VOUS SENTEZ UNE ODEUR DE GAZ:

1. Ouvrez les fenêtres.
2. Ne tentez d'allumer aucun autre appareil.
3. Ne touchez pas aux interrupteurs électriques.
4. Éteignez toute flamme nue.
5. Appelez immédiatement votre compagnie de gaz.

## FOR YOUR SAFETY

The use and storage of gasoline or other flammable vapors and liquids in open containers in the vicinity of this appliance is hazardous.

## POUR VOTRE SÉCURITÉ

L'utilisation et le stockage d'essence ou d'autres vapeurs et liquides inflammables dans des récipients ouverts à proximité de cet appareil sont dangereux.

# TABLE OF CONTENTS

## IMPORTANT

1. The use of this manual is specifically intended for a qualified installation and service agency. A qualified installation and service agency must perform all installation and service of these appliances.
2. This appliance is not intended for use by persons (including children) with reduced physical, sensory, or mental capabilities, or lack of experience and knowledge, unless they have been given supervision or instruction concerning use of the appliance by a person responsible for their safety.
3. Children should be supervised to ensure that they do not play with the appliance.

## IMPORTANT

1. Ce manuel est spécifiquement destiné au personnel d'une entreprise qualifiée d'installation et d'entretien. Toutes les opérations d'installation et d'entretien doivent être confiées à une entreprise qualifiée.
2. Cet appareil n'est pas conçu pour être utilisé ou entretenu par des personnes (y compris des enfants) dont les capacités physiques, sensorielles ou mentales sont réduites, ou qui n'ont pas l'expérience et les connaissances suffisantes, à moins d'être supervisées ou d'avoir obtenu des directives concernant l'utilisation de l'appareil par une personne responsable de leur sécurité.
3. Les enfants doivent être supervisés pour s'assurer qu'ils ne jouent pas avec l'appareil.

## INSPECTION ON ARRIVAL

1. Inspect unit upon arrival. In case of damage, report it immediately to transportation company and your local factory sales representative.
2. Check rating plate on unit to verify that power supply meets available electric power at the point of installation.
3. Inspect unit upon arrival for conformance with description of product (including specifications where applicable).

SHOP DRAWING REVIEW  
PER M/E SPECIFICATIONS SECTIONS

DATE: **2026/04/29** PROJECT No.: **24333-08**

<input type="checkbox"/> NOT REVIEWED	<input checked="" type="checkbox"/> REVIEWED
<input type="checkbox"/> RESUBMIT	<input type="checkbox"/> REVIEWED AS MODIFIED
<input type="checkbox"/> NOT SPECIFIED BY MCW, REVIEWED FOR MEP ONLY	
ELECTRICAL REVIEWER: <u>R.A.</u>	MECHANICAL REVIEWER: <u>TT</u>

# TABLE OF CONTENTS

Inspection On Arrival .....	2
Special Precautions .....	3
Hazard Intensity Levels .....	3
Special Design Requests / Unit Location .....	6
Special Design Requests .....	6
Unit Location .....	6
Location Recommendations .....	6
Sound Attenuation / Roof Curb Installation .....	8
Sound and Vibration Levels .....	8
Curb or Sub-Base Mounted Sites .....	8
Slab Mount Installation / Rigging Instructions .....	10
Slab Mounted Units .....	10
General Rigging Instructions .....	11
Duct Installation / Utility Connections .....	12
Duct Installation .....	12
Utility Connections .....	12
Unit Installation .....	14
Gas Connections .....	14
Considerations for Elevation .....	17
Manifold Pressure Adjustment .....	17
Electrical Connections .....	18
Cooling Coil Units .....	20
Start-Up Procedure .....	22
Start-Up Procedure .....	22
Pilot Burner Adjustment .....	23
Furnace Control Operating Sequence .....	26
Cooling Coil Operation .....	28
Component/Option Locations .....	29
Component Descriptions .....	30
General Performance Data .....	37
General Performance Data .....	38
Option & Accessory Pressure Drop Data .....	39
Blower Performance Data .....	40
General Performance Data .....	42
Blower Sheave Assembly Data .....	43
Dimensions - Unit .....	45
Dimensions - Unit Base .....	49
Dimensions - Roof Curbs .....	50
Dimensions - Cooling Coils .....	51
Dimensions - Rainhood, Remote Panel & Evaporative Cooler .....	52
Weights .....	53
Maintenance .....	54
Electrical Wiring .....	54
Cooling Coil Maintenance .....	55
Cooling Coil Drain Pan and Drain System .....	55
Duct Furnace .....	55
Gas Piping & Controls .....	55
Manifold Assembly Removal .....	56
Burner and Pilot Assembly Removal .....	56
Service & Troubleshooting .....	58
Start-Up Checklist .....	60
Model Designations .....	61
Model Identification .....	61
Replacement Parts Ordering .....	61
Model Nomenclature For System Units .....	62
Weatherproof Model Nomenclature .....	62

# SPECIAL PRECAUTIONS

## SPECIAL PRECAUTIONS

THE INSTALLATION AND MAINTENANCE INSTRUCTIONS IN THIS MANUAL MUST BE FOLLOWED TO PROVIDE SAFE, EFFICIENT, AND TROUBLE-FREE OPERATION. IN ADDITION, PARTICULAR CARE MUST BE EXERCISED REGARDING THE SPECIAL PRECAUTIONS LISTED BELOW. FAILURE TO PROPERLY ADDRESS THESE CRITICAL AREAS COULD RESULT IN PROPERTY DAMAGE OR LOSS, PERSONAL INJURY, OR DEATH. THESE INSTRUCTIONS ARE SUBJECT TO ANY MORE RESTRICTIVE LOCAL OR NATIONAL CODES.

## HAZARD INTENSITY LEVELS

1. **DANGER:** Indicates an imminently hazardous situation which, if not avoided, WILL result in death or serious injury.
2. **WARNING:** Indicates a potentially hazardous situation which, if not avoided, COULD result in death or serious injury.
3. **CAUTION:** Indicates a potentially hazardous situation which, if not avoided, MAY result in minor or moderate injury.
4. **IMPORTANT:** Indicates a situation which, if not avoided, MAY result in a potential safety concern.

## PRÉCAUTIONS PARTICULIÈRES

LES INSTRUCTIONS D'INSTALLATION ET D'ENTRETIEN DE CE MANUEL DOIVENT ÊTRE OBSERVÉES POUR ASSURER UN FONCTIONNEMENT SÉCURITAIRE, EFFICACE ET FIABLE. DE PLUS, LES PRÉCAUTIONS PARTICULIÈRES CI-APRÈS DOIVENT ÊTRE RIGOREUSEMENT RESPECTÉES. SINON, IL Y AURAIT RISQUE DE DÉGÂTS MATÉRIELS OU DE PERTE, DE BLESSURE PERSONNELLE OU DE MORT D'HOMME. CES INSTRUCTIONS SONT SUJETTES À TOUTE DISPOSITION PLUS RESTRICTIVE DES CODES PROVINCIAL OU NATIONAL.

## HIÉRARCHIE DES NIVEAUX DE RISQUES

1. **DANGER :** Indique un danger imminent qui, s'il n'est pas évité, entraînera INÉVITABLEMENT des blessures graves, voire mortelles.
2. **AVERTISSEMENT :** Indique un danger potentiel qui, s'il n'est pas évité, RISQUE d'entraîner des blessures graves, voire mortelles.
3. **ATTENTION :** Indique un danger potentiel qui, s'il n'est pas évité, PEUT entraîner des blessures mineures ou modérées.
4. **IMPORTANT :** Indique une situation qui, si elle se matérialise, PEUT entraîner des risques pour la sécurité des personnes.

## DANGER

Appliances must not be installed where they may be exposed to potentially explosive or flammable atmosphere.

## DANGER

Les appareils ne doivent pas être installés à un endroit où ils risquent d'être exposés à une atmosphère potentiellement explosive ou inflammable.

## WARNING

1. To prevent premature heat exchanger failure, do not locate ANY gas-fired appliances in areas where corrosive vapors (i.e. chlorinated, halogenated or acid) are present in the atmosphere.
2. Failure to follow proper lifting instructions and applicable safety procedures could result in property damage, serious injury, or death. Lifting should only be done by a qualified rigging company. Use ALL lifting points. Test lift to ensure proper balance and rigging. Never lift in high winds.
3. All field gas piping must be pressure/leak tested prior to operation. Never use an open flame. Use a soap solution or equivalent for testing.
4. Gas pressure to appliance controls must never exceed 3.4 kPa (14" W.C. or 1/2 psi).
5. Disconnect power supply before making wiring connections or working on this equipment. Follow all applicable safety procedures to prevent accidental power up. Failure to do so can result in injury or death from electrical shock or moving parts and may cause equipment damage.
6. All appliances must be wired strictly in accordance with wiring diagram furnished with the appliance. Any wiring different from the wiring diagram could result in a hazard to persons and property.
7. Any original factory wiring that requires replacement must be replaced with wiring material having a temperature rating of at least 105°C.
8. To reduce the opportunity for condensation, the minimum sea level input to the appliance, as indicated on the serial plate, must not be less than 5% below the rated input, or 5% below the minimum rated input of dual rated units.
9. Ensure that the supply voltage to the appliance, as indicated on the serial plate, is not 5% greater than the rated voltage.
10. When servicing or repairing this equipment, use only factory-approved service replacement parts. A complete replacement parts list may be obtained by contacting Modine Manufacturing Company. Refer to the rating plate on the appliance for complete appliance model number, serial number, and company address. Any substitution of parts or controls not approved by the factory will be at the owners risk.



SHOP DRAWING REVIEW  
PER M/E SPECIFICATIONS SECTIONS

DATE  
**2026/04/29**

PROJECT No.  
**24333-08**

NOT REVIEWED

REVIEWED

RESUBMIT

REVIEWED AS MODIFIED

NOT SPECIFIED BY MCW, REVIEWED FOR MEP ONLY

ELECTRICAL REVIEWER:  
R.A.

MECHANICAL REVIEWER:  
TT

## SPECIAL PRECAUTIONS

### AVERTISSEMENT

1. Pour éviter la panne prématurée de l'échangeur thermique, ne placez AUCUN appareil à gaz à des endroits où les vapeurs corrosives (chlorées, halogénées ou acides) sont présentes dans l'atmosphère.
2. Le non-respect d'une bonne procédure de levage et des procédures de sécurité qui s'appliquent pourrait mener à des dommages matériels ou à des blessures graves, voire mortelles. Le levage doit être effectué uniquement par une entreprise spécialisée dans le gréage. Utilisez TOUS les points de levage. Testez le levage pour assurer un bon équilibre et un bon gréage. Ne procédez jamais au levage de l'appareil par vents forts.
3. Toutes les canalisations de gaz sur site doivent être testées (pression/fuites) avant usage. Ne recherchez jamais les fuites avec une flamme nue. Utilisez plutôt de l'eau savonneuse ou un produit équivalent.
4. La pression de gaz aux commandes de l'appareil ne doit jamais dépasser 3.4 kPa (35,5 cm C.E. ou 1/2 psi).
5. Débranchez l'alimentation électrique avant d'effectuer des connexions ou de travailler sur l'appareil. Respectez toutes les procédures de sécurité qui s'appliquent pour éviter toute mise en marche accidentelle. Le non-respect de cette directive peut entraîner des blessures ou la mort causées par un choc électrique ou des pièces mobiles, en plus d'endommager l'appareil.
6. Tous les appareils doivent être branchés de manière strictement conforme au diagramme fourni. Tout câblage différent de celui du schéma peut créer des risques de dommages matériels ou de blessures.
7. Tout câblage usine d'origine exigeant un remplacement doit être remplacé par un câble d'indice thermique nominal de 105 °C.
8. Pour réduire le risque de condensation, l'entrée minimum dans l'appareil au niveau de la mer, telle qu'indiquée sur la plaque de série, ne doit pas être moins de 5 % inférieure à la valeur d'entrée nominale des appareils à double valeur nominale.
9. Assurez-vous que la tension d'alimentation de l'appareil, comme indiqué sur la plaque de série, n'est pas de 5 % supérieure à la tension nominale.
10. Pour l'entretien et les réparations de cet appareil, utilisez uniquement des pièces d'origine certifiées. Pour la liste complète des pièces de rechange, consultez Modine Manufacturing Company. Le numéro de modèle complet, le numéro de série et l'adresse du fabricant figurent sur la plaque signalétique fixée à l'appareil. Toute substitution de pièce ou de commande non approuvée par le fabricant sera aux risques du propriétaire.

### CAUTION

1. Appliances are designed for outdoor installation only. DO NOT LOCATE APPLIANCES INDOORS.
2. Purging of air from gas lines should be performed as described in ANSI Z223.1 - latest edition "National Fuel Gas Code", or in Canada in CAN/CGA-B149 codes.
3. Ensure that the supply voltage to the appliance, as indicated on the serial plate, is not 5% less than the rated voltage.
4. Do not attempt to reuse any mechanical or electrical component which has been wet. Such component must be replaced.

### ATTENTION

1. Ces appareils sont conçus pour une installation à l'extérieur seulement. NE PLACEZ PAS LES APPAREILS À L'INTÉRIEUR.
2. La purge de l'air des tuyauteries de gaz doit se faire selon la procédure ANSI Z223.1 de la dernière édition du « National Fuel Gas Code » ou des codes CAN/CGA-B149 du Canada.
3. Vérifiez que la tension d'alimentation de l'appareil n'est pas inférieure de plus de 5 % à la tension nominale inscrite sur la plaque de série.
4. Ne tentez pas de réutiliser un composant mécanique ou électrique qui a été mouillé. Ces composants doivent être remplacés.



SHOP DRAWING REVIEW  
PER M/E SPECIFICATIONS SECTIONS

DATE

2026/04/29

PROJECT No.

24333-08

NOT REVIEWED

REVIEWED

RESUBMIT

REVIEWED AS MODIFIED

NOT SPECIFIED BY MCW, REVIEWED FOR MEP ONLY

ELECTRICAL REVIEWER:

R.A.

MECHANICAL REVIEWER:

TT

# SPECIAL PRECAUTIONS

## IMPORTANT

1. For installation only in locations not accessible to the general public.
2. Unit can be operated up to a maximum of 10,000 feet (3048 m).
3. To prevent premature heat exchanger failure, the input to the appliance, as indicated on the serial plate, must not exceed the rated input by more than 5%.
4. To prevent premature heat exchanger failure, observe heat exchanger tubes by looking at the heat exchanger through the field installed access openings in connecting ductwork or the unit access doors where viewing the heat exchanger is possible. If the bottom of the tubes become red while blower and duct furnace are in operation, check to be sure the blower has been set to the proper rpm for the application. Refer to page 26 for Blower Adjustments.
5. Start up and adjustment procedures, installation, and service of these appliances must be performed by a qualified installation and service agency.
6. To prevent premature heat exchanger failure, with all control systems, a blower starting mechanism must be provided so that the blower is running or energized within 45 seconds of the gas control operation.
7. To check most of the Possible Remedies in the troubleshooting guide listed in Table 58.1, and refer to the applicable sections of the manual.

## IMPORTANT

1. À installer uniquement dans des endroits non accessibles au grand public.
2. L'unité peut être utilisée jusqu'à un maximum de 3048 m (10,000 ft).
3. Pour éviter une défaillance prématurée de l'échangeur de chaleur, le pouvoir calorifique du gaz utilisé ne doit pas excéder de plus de 5 % la valeur nominale inscrite sur la plaque signalétique de l'appareil.
4. Pour éviter la défaillance prématurée de l'échangeur de chaleur, examinez les tubes de l'échangeur de chaleur en le regardant à travers les ouvertures d'accès installées sur les lieux lors de la connexion des tuyaux ou les portes d'accès à l'unité où il est possible de voir l'échangeur de chaleur. Si le bas des tubes devient rouge lorsque la soufflante et la chaudière canalisée sont en marche, vérifiez que le régime de la soufflante est approprié pour l'application. Pour le réglage de la soufflante, reportez-vous à la page 26.
5. Les procédures de démarrage et de réglage, l'installation et le service de ces appareils doivent être confiés à un centre d'installation et de service qualifié.
6. Pour éviter une panne prématurée de l'échangeur de chaleur, avec tous les systèmes de commande, un mécanisme de démarrage du ventilateur doit être fourni de manière à ce que le ventilateur soit en marche ou sous tension 45 secondes de l'opération de contrôle du gaz.
7. Pour essayer la plupart des solutions possibles suggérées dans le guide de dépannage du Tableau 58.1 reportez-vous aux sections correspondantes du manuel.

Table 5.1 - SI (Metric) Conversion Factors

To Convert	Multiply By	To Obtain	To Convert	Multiply By	To Obtain
"W.C.	0.24	kPa	CFH	1.699	m <sup>3</sup> /min
psig	6.893	kPa	Btu/ft <sup>3</sup>	0.0374	mJ/m <sup>3</sup>
°F	(°F-32) x 0.555	°C	pound	0.453	kg
inches	25.4	mm	Btu/hr	0.000293	kW
feet	0.305	meters	gallons	3.785	liters
CFM	0.028	m <sup>3</sup> /min	psig	27.7	"W.C.



SHOP DRAWING REVIEW  
PER M/E SPECIFICATIONS SECTIONS

DATE  
**2026/04/29**

PROJECT No.  
**24333-08**

NOT REVIEWED

REVIEWED

RESUBMIT

REVIEWED AS MODIFIED

NOT SPECIFIED BY MCW, REVIEWED FOR MEP ONLY

ELECTRICAL REVIEWER:

MECHANICAL REVIEWER:

R.A.

TT

# SPECIAL DESIGN REQUESTS / UNIT LOCATION

## Special Design Requests

Modine Manufacturing Company will sometimes build units with special features as requested by the customer. This manual only covers standard features and does not include any changes made for special feature requests by the customer. Units built with special features are noted with a 5-digit SPO (Special Product Order) Number on the Serial Plate

## STORAGE PRIOR TO INSTALLATION

If the unit is stored outside prior to installation, the unit should be covered.

## Unit Location

**⚠ DANGER**

Appliances must not be installed where they may be exposed to potentially explosive or flammable atmosphere.

**⚠ DANGER**

Les appareils ne doivent pas être installés à un endroit où ils risquent d'être exposés à une atmosphère potentiellement explosive ou inflammable.

**⚠ WARNING**

To prevent premature heat exchanger failure, do not locate ANY gas-fired appliances in areas where corrosive vapors (i.e. chlorinated, halogenated or acid) are present in the atmosphere.

**⚠ AVERTISSEMENT**

Pour éviter la panne prématurée de l'échangeur thermique, ne placez AUCUN appareil à gaz à des endroits où les vapeurs corrosives (chlorées, halogénées ou acides) sont présentes dans l'atmosphère.

**⚠ CAUTION**

Appliances are designed for outdoor installation only. DO NOT LOCATE APPLIANCES INDOORS.

**⚠ ATTENTION**

Ces appareils sont conçus pour une installation à l'extérieur seulement. NE PLACEZ PAS LES APPAREILS À L'INTÉRIEUR.

**IMPORTANT**

1. For installation only in locations not accessible to the general public.
2. Unit can be operated up to a maximum of 10,000 feet (3048 m).

**IMPORTANT**

1. Pour installation uniquement dans des endroits non accessibles au public.
2. L'unité peut être utilisée jusqu'à un maximum de 3048 m (10,000 ft).

## Location Recommendations

1. When locating the furnace, consider general space and heating requirements and availability of gas and electrical supply.
2. Unit must be installed on the positive pressure side of the circulating blower.
3. Be sure the structural support at the unit location site is adequate to support the weight of the unit and any other required support structure. For proper operation the unit must be installed in a level horizontal position.
4. Do not install units in locations where the flue products can be drawn into the adjacent building openings such as windows, fresh air intakes, etc.
5. Be sure that the minimum clearances to combustible materials and recommended service clearances are maintained. Be sure clearances are maintained to combustion air inlet louvers and power exhauster discharge cover. Units are designed for installation on non-combustible surfaces or combustible surfaces with the minimum clearances shown in Figure 6.1 and Table 7.1.

NOT REVIEWED       REVIEWED  
 RESUBMIT       REVIEWED AS MODIFIED  
 NOT SPECIFIED BY MCW, REVIEWED FOR BIR ONLY  
 DATE: 2025/04/29      PROJECT No: 24333-08  
 ELECTRICAL REVIEWER:      MECHANICAL REVIEWER:

Figure 6.1 - Combustible Material & Service Clearances ①

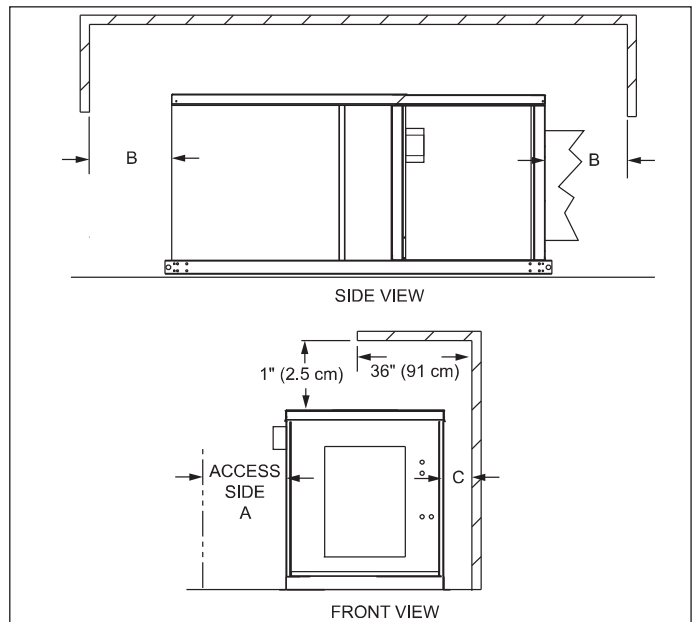

① Minimum clearance to combustible materials is 1" (2.5 cm) from rooftop.

# UNIT LOCATION

Figure 7.1 -  
Matériaux combustibles et dégagement ①

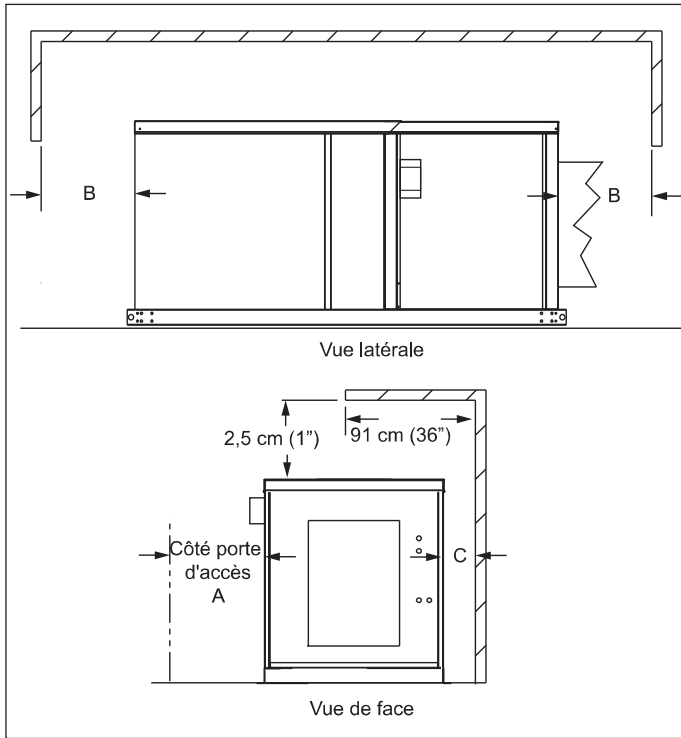

① Le dégagement minimal jusqu'au matériau combustible est de 2,5 cm (1 in) à partir du toit.

Tableau 7.1 -  
Matériaux combustibles et dégagements

Taille de modèle	Dégagements minimaux jusqu'au matériau combustible			Dégagements recommandés pour l'entretien	
	Côté porte d'accès (A)	Avant et arrière (B)	Côté opposé à la porte (C)	Côté porte d'accès (A)	Côté opposé à la porte (C)
100/125	20" (51 cm)	3" (8 cm)	0"	36" (91 cm)	6" (15 cm)
150/175	25" (64 cm)	3" (8 cm)	0"	42" (107 cm)	
200/225	27" (69 cm)	4" (10 cm)	0"	42" (107 cm)	
250/300	30" (76 cm)	5" (13 cm)	0"	48" (123 cm)	36" (91 cm)①
350/400	41" (104 cm)	11" (28 cm)	0"	60" (152 cm)	
500/600	30" (76 cm)	5" (13 cm)	0"	48" (123 cm)	
700/800	41" (104 cm)	11" (28 cm)	0"	60" (152 cm)	
840/960	41" (104 cm)	11" (28 cm)	0"	60" (152 cm)	

① Pour les modèles avec VFD montés en usine

Table 7.1 -  
Combustible Material & Service Clearances

Model Size	Minimum Combustible Material Clearances			Recommended Service Clearances	
	Access Side (A)	Front & Rear (B)	Non-Access Side (C)	Access Side (A)	Non-Access Side (C)
100/125	20" (51 cm)	3" (8 cm)	0"	36" (91 cm)	6" (15 cm)
150/175	25" (64 cm)	3" (8 cm)	0"	42" (107 cm)	
200/225	27" (69 cm)	4" (10 cm)	0"	42" (107 cm)	
250/300	30" (76 cm)	5" (13 cm)	0"	48" (123 cm)	36" (91 cm)①
350/400	41" (104 cm)	11" (28 cm)	0"	60" (152 cm)	
500/600	30" (76 cm)	5" (13 cm)	0"	48" (123 cm)	
700/800	41" (104 cm)	11" (28 cm)	0"	60" (152 cm)	
840/960	41" (104 cm)	11" (28 cm)	0"	60" (152 cm)	

① For models with factory mounted VFDs

**MCW** SHOP DRAWING REVIEW  
PER M/E SPECIFICATIONS SECTIONS

DATE: **2026/04/29** PROJECT No. **24333-08**

NOT REVIEWED       REVIEWED

RESUBMIT       REVIEWED AS MODIFIED

NOT SPECIFIED BY MCW, REVIEWED FOR MEP ONLY

ELECTRICAL REVIEWER: R.A.      MECHANICAL REVIEWER: TT

# SOUND ATTENUATION / ROOF CURB INSTALLATION

## SOUND AND VIBRATION LEVELS

All mechanical equipment generates some sound and vibration that may require attenuation. For critical areas, an acoustical consultant should be retained to assist in the application. Locating the equipment away from the critical area is desirable within ducting limitations. Frequently, units can be located above utility areas, corridors, restrooms, and other non-critical areas. Generally, a unit should be located within 15 feet (457 cm) of a primary support beam to minimize structure deflections. Smaller deflections usually results in reduced vibration and noise transmission.

Install the unit over roof decking with 2" (5 cm) acoustic fiberglass lining within curb area for sound attenuation. The return air duct should be acoustically lined and should be installed with a flexible connection. If the ceiling space is used as a plenum, the acoustically lined return intake duct should form an inverted tee with five foot minimum legs in each direction.

The discharge duct should be acoustically insulated and should have a flexible connection as illustrated.

**Figure 8.1 - Suggested Sound Attenuation**

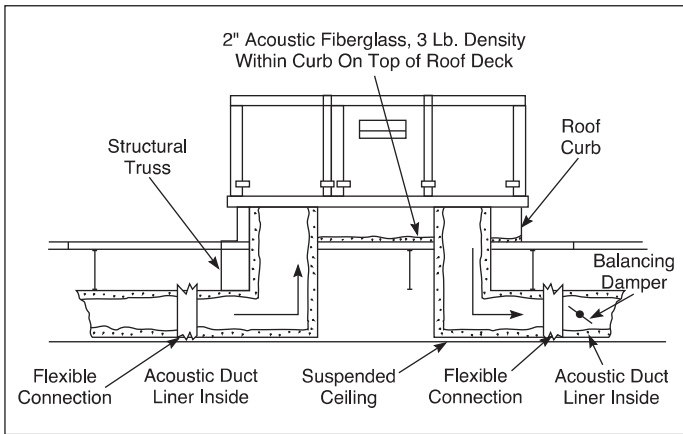

4. Outside dimensions must be held when installing curb. Top surface must be level and straight to insure weather-tightness. All corners must be square.
5. Final electric and gas connections must be made after unit is installed to allow for tolerance in setting of unit on curb. For electrical power supply allow approximately eight feet of wire, plus provisions for weathertight flexible conduit for connection to unit, as required by local codes.
6. Maintain a 12" (30 cm) minimum height from top of roof deck to top of curb.
7. Caulk butt joints after curb is assembled and installed on roof structural members and roof flashing is added.

**Figure 8.2 - Typical Curb Details**

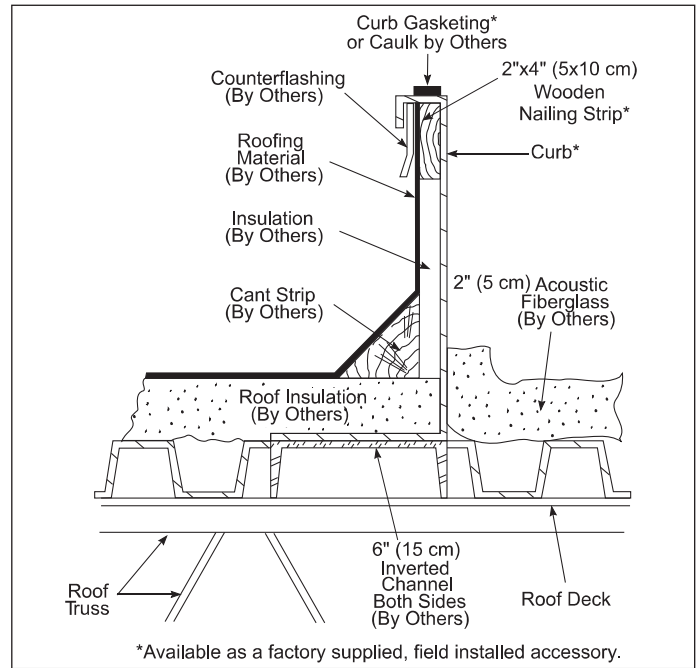

## CURB OR SUB-BASE MOUNTED SITES

An optional roof curb is available to simplify site preparation and raise the unit above roof water and snow level for drainage. It can be installed with the roof, and in advance of the unit. A sub-base must be furnished by the installer if no curb is supplied for the roof. The sub-base, either steel or concrete, must provide required support with the unit bolted to sub-base. The following are some general guidelines for roof curb installed units:

1. The roof structure must be adequately designed to support the live weight load of the unit and any other required support structure. For the bearing loads normally encountered, the roof curb should be supported at points no greater than 5 feet (152 cm) apart. Additional truss reinforcement should be provided, if necessary.
2. Roof curb must be installed level. If roof is pitched it will be necessary to construct a sub-base on which to install the curb.
3. Roof curbs supplied by Modine are fabricated from 16 gauge galvanized steel and supplied knocked down for assembly on the job site. The curb consists of two side pieces, two end pieces, gasketing, four joiner angles, four 2"x4" (5x10 cm) wood nailing strips, nuts, bolts, and washers. Roof curbs over 120" (305 cm) long include two additional side pieces and two splice plates. Refer to the latest revision of Modine literature 5-590 for instructions.

	SHOP DRAWING REVIEW	
	PER M/E SPECIFICATIONS SECTIONS	
DATE	PROJECT No.	
2026/04/29	24333-08	
<input type="checkbox"/> NOT REVIEWED	<input checked="" type="checkbox"/> REVIEWED	
<input type="checkbox"/> RESUBMIT	<input type="checkbox"/> REVIEWED AS MODIFIED	
<input type="checkbox"/> NOT SPECIFIED BY MCW, REVIEWED FOR MEP ONLY		
ELECTRICAL REVIEWER:	MECHANICAL REVIEWER:	
R.A.	TT	

# ROOF CURB INSTALLATION

## SITES D'INSTALLATION SUR REBORD OU SOUS-FONDATION

Un rebord de toit est proposé en option pour simplifier la préparation du site et rehausser l'appareil au-dessus des niveaux d'eau et de neige sur le toit pour l'évacuation. Il peut être installé avec le toit et avant l'appareil. Une sous-fondation doit être prévue par l'installateur si aucun rebord n'est fourni pour le toit. La sous-fondation, en acier ou en béton, doit offrir le soutien requis une fois l'appareil boulonné à celle-ci. Directives générales pour les appareils installés sur un rebord de toit :

1. La structure du toit doit être correctement conçue pour soutenir la charge utile de l'appareil et de toute autre structure de soutien requise. Pour les charges normalement rencontrées, le rebord de toit doit être soutenu à des endroits se trouvant à une distance maximale de 152 cm (5 ft). Au besoin, une poutre de renforcement supplémentaire devra être fournie.
2. Le rebord de toit doit être installée de niveau. Si le toit est incliné, il faudra prévoir la construction d'une sous-fondation sur laquelle le rebord sera installé.
3. Les rebords de toit offerts par Modine sont fabriqués avec de l'acier galvanisé de calibre 16 et fournis démontés pour l'assemblage sur le chantier. Le rebord comprend deux pièces latérales, deux pièces d'extrémité, des joints, quatre angles de menuisier, quatre bandes de clouage en bois de 5 x 10 cm (2" x 4"), des écrous, des boulons et des rondelles. Les rebords de toit mesurant plus de 305 cm (120") de longueur incluent deux pièces latérales supplémentaires et deux plaques d'épissure. Pour les instructions, reportez-vous à la dernière version de la documentation 5-590 de Modine.
4. Les dimensions extérieures doivent être respectées lors de l'installation du rebord. La surface supérieure doit être de niveau et droite pour assurer l'étanchéité météorologique. Tous les angles doivent être carrés.
5. Les branchements électriques et raccordements au gaz définitifs doivent être établis après l'installation de l'appareil sur le rebord. Pour l'alimentation électrique, comptez approximativement 2,4 m (8 ft) de câble et prévoyez un conduit flexible étanche pour le raccordement à l'appareil, selon les exigences des codes locaux.
6. Maintenez une hauteur minimale de 30 cm (12") du haut du platelage de toit jusqu'à la partie supérieure du rebord.
7. Calfeutrez les aboutages une fois le rebord assemblé et installé sur les membres structuraux du toit et après avoir ajouté le solin de toit.

Figure 9.1 - Détails d'un rebord typique

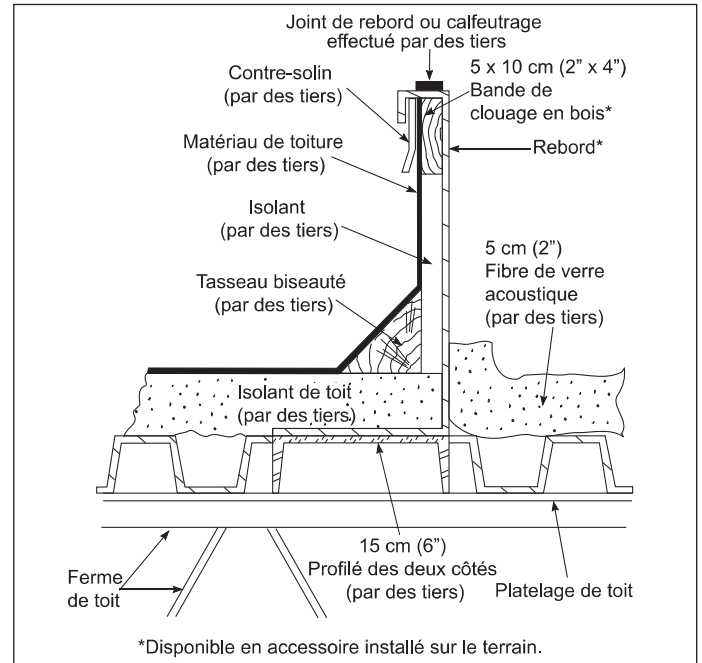

	<b>SHOP DRAWING REVIEW</b> PER M/E SPECIFICATIONS SECTIONS	
	DATE <b>2026/04/29</b>	PROJECT No. <b>24333-08</b>
<input type="checkbox"/> NOT REVIEWED	<input checked="" type="checkbox"/> REVIEWED	
<input type="checkbox"/> RESUBMIT	<input type="checkbox"/> REVIEWED AS MODIFIED	
<input type="checkbox"/> NOT SPECIFIED BY MCW, REVIEWED FOR MEP ONLY		
ELECTRICAL REVIEWER: <b>R.A.</b>	MECHANICAL REVIEWER: <b>TT</b>	

# SLAB MOUNT INSTALLATION / RIGGING INSTRUCTIONS

## Slab Mounted Units

### For Horizontal Discharge (Model Digit 2=B or C)

For ground level installation of a horizontal-discharge unit, prepare a level concrete slab at least 4" (10 cm) thick on adequate footings and a generous bed of gravel for drainage (See Figure 10.1). The slab should include threaded 5/8-inch anchor bolts spaced as shown in Figure 10.1 and Table 10.1. Anchor bolts should extend at least 1.5" (4 cm) above the surface of the pad to allow clearance for mounting washers, nuts and bolts (mounting washers, nuts and bolts by others). The slab should extend out at least 6" (15 cm) around the perimeter of the unit.

### Modèles montés sur dalle

#### Pour l'évacuation horizontale (dont le deuxième caractère du numéro de modèle = B ou C)

Pour l'installation au niveau du sol d'un appareil à évacuation horizontale, préparez une dalle de béton de niveau d'une épaisseur d'au moins 10 cm (4") sur des semelles adéquates et un lit généreux de gravier pour l'évacuation (reportez-vous à la Figure 10.2). La dalle doit comprendre des boulons d'ancrage filetés de 5/8" espacés comme dans la Figure 10.2 et le Tableau 11.1. Les boulons d'ancrage doivent se prolonger au-delà de la surface de la dalle d'au moins 4 cm (1,5") pour permettre un dégagement suffisant pour la mise en place des rondelles, des boulons et des écrous (par des tiers). La dalle doit se prolonger d'au moins 15 cm (6") autour de l'appareil.

Figure 10.1 - Slab-Mounted Make-Up Air Unit

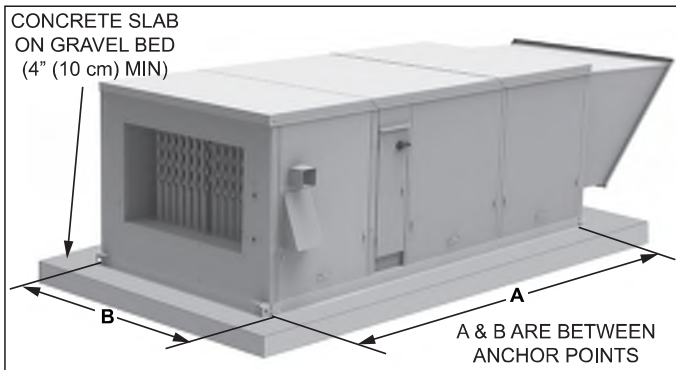

Figure 10.2 - Modèle d'air d'appoint installé sur dalle

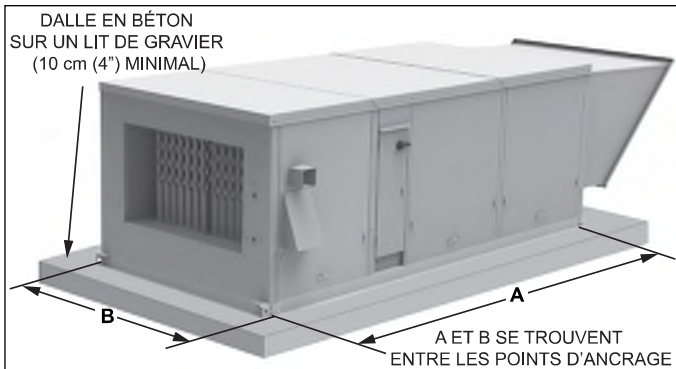

Table 10.1 - Slab Anchor Bolt Dimensions

Digit 2	Model Size	Blower Type (Digit 16)	A	B
B	100/125	All	82.91" (2105.9 cm)	36.36" (923.5 cm)
	150/175	All	82.91" (2105.9 cm)	40.61" (1031.5 cm)
	200/225	All	82.91" (2105.9 cm)	42.71" (1084.8 cm)
	250/300	E, F, G, or H	82.91" (2105.9 cm)	45.75" (1162.1 cm)
		I, J, or K	118.5" (3009.9 cm)	45.75" (1162.1 cm)
	350/400	E, F, G, or H	82.91" (2105.9 cm)	57.27" (1454.7 cm)
		I, J, or K	118.5" (3009.9 cm)	57.27" (1454.7 cm)
	500/600	G or H	116.03" (2947.2 cm)	45.75" (1162.1 cm)
		I, J, K, or L	151.62" (3851.2 cm)	45.75" (1162.1 cm)
	700/800	G or H	116.03" (2947.2 cm)	57.27" (1454.7 cm)
I, J, K, or L		151.62" (3851.2 cm)	57.27" (1454.7 cm)	
840/960	All	185.02" (4699.5 cm)	57.27" (1454.7 cm)	
C	100/125	All	106.89" (2715.0 cm)	36.36" (923.5 cm)
	150/175	All	106.89" (2715.0 cm)	40.61" (1031.5 cm)
	200/225	All	106.89" (2715.0 cm)	42.71" (1084.8 cm)
	250/300	E, F, G, or H	106.89" (2715.0 cm)	45.75" (1162.1 cm)
		I, J, or K	142.48" (3619.0 cm)	45.75" (1162.1 cm)
	350/400	E, F, G, or H	106.89" (2715.0 cm)	57.27" (1454.7 cm)
		I, J, or K	142.48" (3619.0 cm)	57.27" (1454.7 cm)

**SHOP DRAWING REVIEW**  
PER M/E SPECIFICATIONS SECTIONS

DATE: **2026/04/29** PROJECT No.: **24333-08**

NOT REVIEWED                       REVIEWED  
 RESUBMIT                               REVIEWED AS MODIFIED  
 NOT SPECIFIED BY MCW, REVIEWED FOR MEP ONLY

ELECTRICAL REVIEWER: R.A.                      MECHANICAL REVIEWER: TT

# SLAB MOUNT INSTALLATION / RIGGING INSTRUCTIONS

Tableau 11.1 -  
Dimensions des boulons d'ancrage à la dalle

2 <sup>e</sup> chiffre	Taille de modèle	Type de ventilateur (16 <sup>e</sup> chiffre)	A	B
B	100/125	Tout	82.91" (2105.9 cm)	36.36" (923.5 cm)
	150/175	Tout	82.91" (2105.9 cm)	40.61" (1031.5 cm)
	200/225	Tout	82.91" (2105.9 cm)	42.71" (1084.8 cm)
	250/300	E, F, G, or H	82.91" (2105.9 cm)	45.75" (1162.1 cm)
		I, J, or K	118.5" (3009.9 cm)	45.75" (1162.1 cm)
	350/400	E, F, G, or H	82.91" (2105.9 cm)	57.27" (1454.7 cm)
		I, J, or K	118.5" (3009.9 cm)	57.27" (1454.7 cm)
	500/600	G or H	116.03" (2947.2 cm)	45.75" (1162.1 cm)
		I, J, K, or L	151.62" (3851.2 cm)	45.75" (1162.1 cm)
	700/800	G or H	116.03" (2947.2 cm)	57.27" (1454.7 cm)
I, J, K, or L		151.62" (3851.2 cm)	57.27" (1454.7 cm)	
840/960	Tout	185.02" (4699.5 cm)	57.27" (1454.7 cm)	
C	100/125	Tout	106.89" (2715.0 cm)	36.36" (923.5 cm)
	150/175	Tout	106.89" (2715.0 cm)	40.61" (1031.5 cm)
	200/225	Tout	106.89" (2715.0 cm)	42.71" (1084.8 cm)
	250/300	E, F, G, or H	106.89" (2715.0 cm)	45.75" (1162.1 cm)
		I, J, or K	142.48" (3619.0 cm)	45.75" (1162.1 cm)
	350/400	E, F, G, or H	106.89" (2715.0 cm)	57.27" (1454.7 cm)
		I, J, or K	142.48" (3619.0 cm)	57.27" (1454.7 cm)

## General Rigging Instructions

### **⚠ WARNING**

Failure to follow proper lifting instructions and applicable safety procedures could result in property damage, serious injury, or death. Lifting should only be done by a qualified rigging company. Use ALL lifting points. Test lift to ensure proper balance and rigging. Never lift in high winds.

### **⚠ AVERTISSEMENT**

Le non-respect d'une bonne procédure de levage et des procédures de sécurité qui s'appliquent pourrait mener à des dommages matériels ou à des blessures graves, voire mortelles. Le levage doit être effectué uniquement par une entreprise spécialisée dans le gréage. Utilisez TOUS les points de levage. Testez le levage pour assurer un bon équilibre et un bon gréage. Ne procédez jamais au levage de l'appareil par vents forts.

Rigging and lifting of the units should only be done by a qualified rigging company and follow appropriate industry standards, including but not limited to the appropriate sections of ASME B30, OSHA 1910, and OSHA 1926.

Four 3/4-inch holes at the extended ends of the mounting channels are supplied to facilitate lifting the unit with eyebolts furnished by the installer. With the lifting points identified, the units can be lifted by crane or helicopter.

- Follow site preparation instructions for the roof curb, slab, or equipment stand before installation.
- Check the Serial Plate(s) of unit with plans to be sure unit is properly located. Although units may look outwardly similar, their function, capacities, options, and accessories will often vary.
- Check unit dimensions of both the unit base and the curb or stand on which the unit will be installed.
- If the unit will be installed on a roof curb:
  - Thoroughly clean and dry the top of the curb surface.
  - Lay a bead of weather resistant caulking on top perimeter of roof curb as illustrated in Figure 8.2. Note: If roof curb is supplied by Modine, full perimeter gasket material is supplied and caulking is not necessary.
- When lifting the equipment, connect sturdy steel cables, chains, or straps with eye loops as illustrated in Figure 11.1. For stability in lifting and lowering and to

SHOP DRAWING REVIEW  
PER M/E SPECIFICATIONS SECTIONS  
DATE: 2026/04/29 PROJECT No: 24333-08

6.  NO REVIEWED  OVER REVIEWED  
 RESUBMIT  REVIEWED AS MODIFIED

7.  NOT SPECIFIED BY MCW REVIEWED FOR MEP ONLY

ELECTRICAL REVIEWER: MECHANICAL REVIEWER:  
R.A. TT

8. Following the instructions in this manual, make final unit connections for ductwork, utilities, and controls.

Figure 11.1 - Typical Rigging

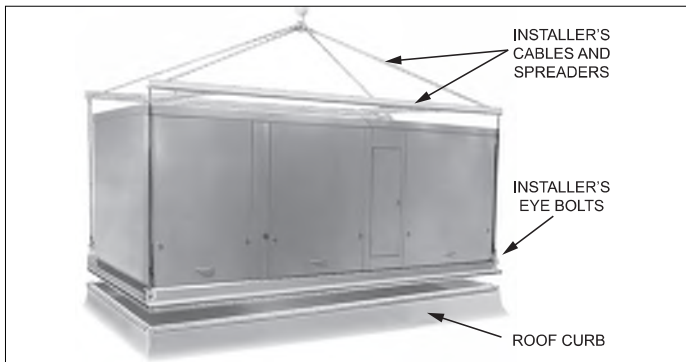

# DUCT INSTALLATION / UTILITY CONNECTIONS

## Duct Installation

1. The blower section inlet and/or return air connections, as well as the furnace furnace discharge are designed to accept 90° flanged ductwork as shown in Figure 12.1. To determine locations and dimensions of connections, refer to the dimensional drawings later in this manual.

**Figure 12.1 - Duct Connections**

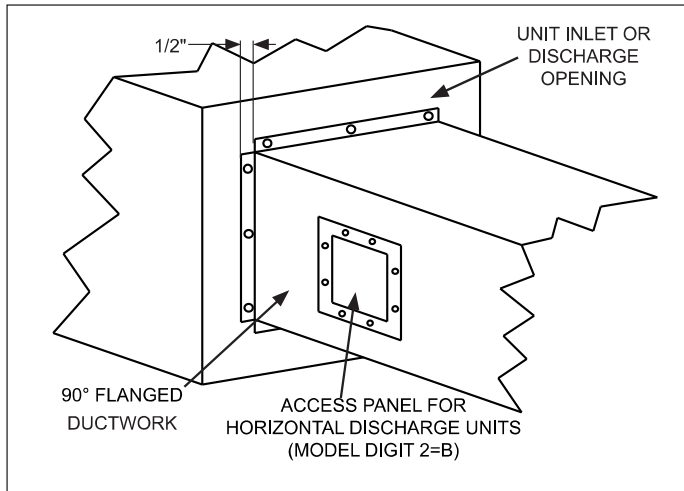

2. Provide an airtight seal between the ductwork and the unit. Seams with cracks in the ductwork should be permanently caulked and/or taped. All duct connections outside the building MUST be weathertight to prevent rain and snow from entering the ductwork.
3. Acoustic duct liners are recommended on all internal supply and return air ducts.
4. Provide uniform air distribution over the heat exchanger. Use turning vanes in the supply ductwork where required to obtain uniform air distribution. See Figure 12.2.

**Figure 12.2 - Recommended Discharge Duct Configs**

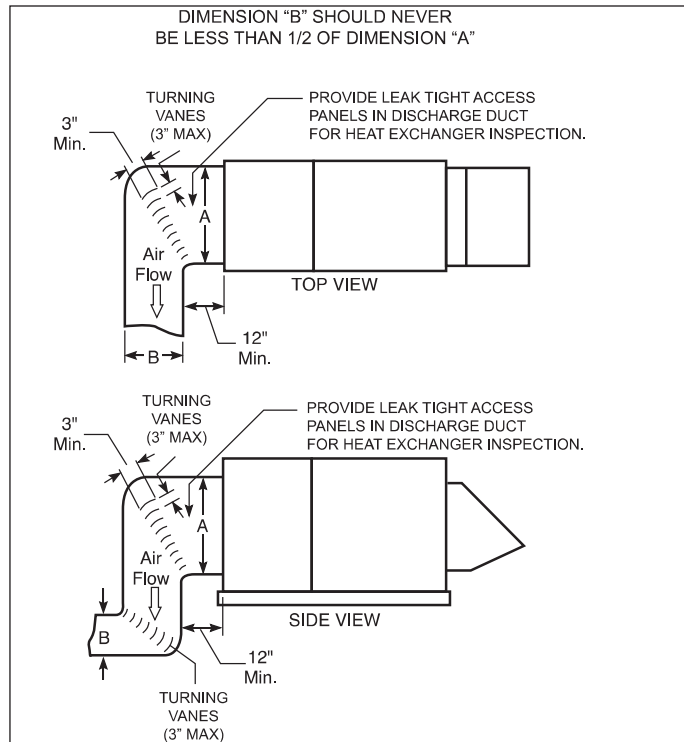

5. On horizontal discharge units with Model Digit 2=B, provide removable access panels on the downstream side of the unit as shown in Figure 12.1. These openings should be large enough to view smoke or reflect light inside the casing to indicate leaks in the heat exchanger and to check for hot spots on the heat exchanger due to a lack of sufficient airflow (CFM). This is not required on horizontal discharge units with Model Digit 2=C because the cooling coil cabinet access door can be removed for this purpose.
6. When a roof curb is used in conjunction with a factory supplied return air connector, the ductwork can be fastened to the connectors prior to the unit installation. The connectors will accept 90° flanged ductwork. See Figure 12.3.

**Figure 12.3 - Discharge and/or Return Air Connectors**

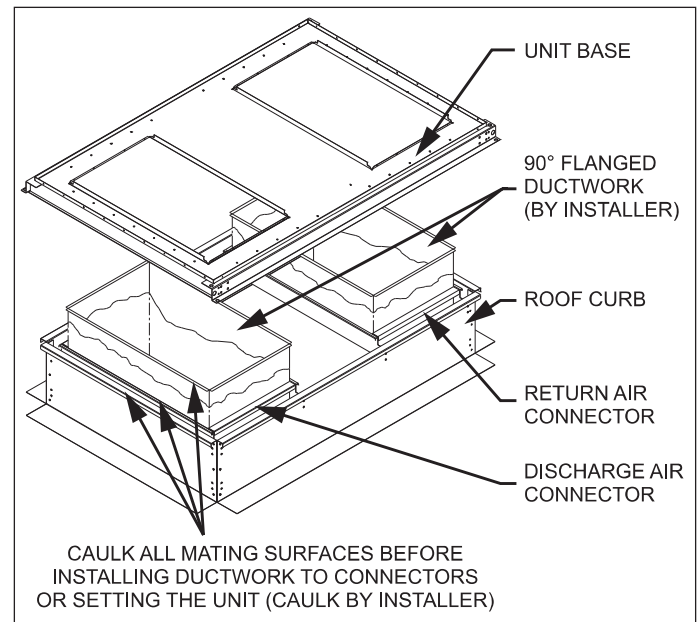

## Utility Connections

Utility and control connections can be made to the unit from the bottom for roof curb-mounted units or through the fixed side panels for horizontal supply and return units. Holes can be made in fixed side panels to accommodate utility connections as specified according to the unit dimensional drawings. Sealing of holes cut in the unit casing for utility connections should be done with care to prevent air and water leaks.

## Venting

1. Installation of venting must conform with local building codes, or in the absence of local codes, with the National Fuel Gas Code, ANSI Z223.1 (NFPA 54), Latest Edition.
2. Units are shipped with the power exhauster discharge cover factory installed.
3. Do not modify or obstruct the combustion air inlet louvers or the power exhauster discharge cover.
4. Do not add any vents other than those supplied by the manufacturer.

MSW Canada, installation must be in accordance with CAN/B149.1 for natural gas units and CAN/CGA-B149.2 for propane units.

DATE: 2026/04/29

PROJECT No. 24333-08

NOT REVIEWED

REVIEWED

RESUBMIT

REVIEWED AS MODIFIED

NOT SPECIFIED BY MSW

REVIEWED FOR MSW ONLY

ELECTRICAL REVIEWER: R.A.

MECHANICAL REVIEWER: TT

**THIS PAGE INTENTIONALLY LEFT BLANK**

# UNIT INSTALLATION

## Gas Connections

### ⚠ WARNING

1. All field gas piping must be pressure/leak tested prior to operation. Never use an open flame. Use a soap solution or equivalent for testing.
2. Gas pressure to appliance controls must never exceed 3.4 kPa (14" W.C. or 1/2 psi).
3. To reduce the opportunity for condensation, the minimum sea level input to the appliance, as indicated on the serial plate, must not be less than 5% below the rated input, or 5% below the minimum rated input of dual rated units.

### ⚠ AVERTISSEMENT

1. Toutes les canalisations de gaz sur site doivent être testées (pression/fuites) avant usage. Ne recherchez jamais les fuites avec une flamme nue. Utilisez plutôt de l'eau savonneuse ou un produit équivalent.
2. La pression de gaz aux commandes de l'appareil ne doit jamais dépasser 3.4 kPa (35,5 cm C.E. ou 1/2 psi).
3. Pour réduire le risque de condensation, l'entrée minimum dans l'appareil au niveau de la mer, telle qu'indiquée sur la plaque de série, ne doit pas être moins de 5 % inférieure à la valeur d'entrée nominale des appareils à double valeur nominale.

### ⚠ CAUTION

Purging of air from gas supply line should be performed as described in ANSI Z223.1 - latest edition "National Fuel Gas Code", or in Canada in CAN/CGA-B149 codes.

### ⚠ ATTENTION

La purge de l'air des tuyauteries de gaz doit se faire selon la procédure ANSI Z223.1 de la dernière édition du « National Fuel Gas Code » ou des codes CAN/CGA-B149 du Canada.

### IMPORTANT

1. Unit can be operated up to a maximum of 10,000 feet (3048 m).
2. To prevent premature heat exchanger failure, the input to the appliance, as indicated on the serial plate, must not exceed the rated input by more than 5%.

### IMPORTANT

1. L'unité peut être utilisée jusqu'à un maximum de 3048 m (10,000 ft).
2. Pour éviter une défaillance prématurée de l'échangeur de chaleur, le pouvoir calorifique du gaz utilisé ne doit pas excéder de plus de 5 % la valeur nominale inscrite sur la plaque signalétique de l'appareil.

1. Installation of piping must conform with local building codes, or in the absence of local codes, with the National Fuel Gas Code, ANSI Z223.1 (NFPA 54) - Latest Edition. In Canada, installation must be in accordance with CAN/CGA-B149.1 for natural gas units and CAN/CGA-B149.2 for propane units.
2. Piping to units should conform with local and national requirements for type and volume of gas handled, and pressure drop allowed in the line.
3. Refer to Model Digits 4-6 of the Model Nomenclature on page 62 and the value on the unit Model ID plate (not individual furnace serial plates) to determine the gas heating capacity in Thousands of Btu/hr (MBH). The Model ID plate is located on the blower section electrical compartment door. See Figure 61.3 for an example Model ID plate.
4. For the length of pipe necessary, determine the pipe diameter from Table 16.1 or Table 16.2 for the unit heating capacity. Where several units are served by the same main, the total capacity and length of main must be considered. While the gas connection(s) on the unit may be smaller than the required supply pipe diameter, do not use pipe sizes smaller than what is required leading up to the unit. At the unit, reduce the pipe size down to the appropriate size (sizes 100-225 are 1/2" connections, 250-960 are 3/4" connections). Avoid pipe sizes smaller than 1/2". The inlet pressure to the unit must be 6-7" W.C. for natural gas and 11-14" W.C. for propane gas. When sizing the inlet gas pipe diameter, be sure the unit supply pressure can be met after the line pressure drop has been subtracted. If the line pressure drop is too high, refer to NFPA 54 National Fuel Gas Code for other gas pipe capacities.
5. The gas piping to the unit can enter the unit from the side of the unit or from below. Install a ground joint union with brass seat and a manual shut-off valve external of the unit casing, and adjacent to the unit for emergency shut-off and easy servicing of controls, including a 1/8" NPT plugged tapping accessible for test gauge connection (See Figure 15.1). Verify the manual shut-off valve is gas tight on an annual basis.
6. Provide a sediment trap before each unit in the line where low spots cannot be avoided. (See Figure 15.1).



SHOP DRAWING REVIEW  
PER M/E SPECIFICATIONS SECTIONS

DATE  
2026/04/29

PROJECT No.  
24333-08

NOT REVIEWED

REVIEWED

RESUBMIT

REVIEWED AS MODIFIED

NOT SPECIFIED BY MCW, REVIEWED FOR MEP ONLY

ELECTRICAL REVIEWER:  
R.A.

MECHANICAL REVIEWER:  
TT

# UNIT INSTALLATION

**Figure 15.1 - Recommended Sediment Trap/Manual Shut-off Valve Installation - Side or Bottom Gas Connection**

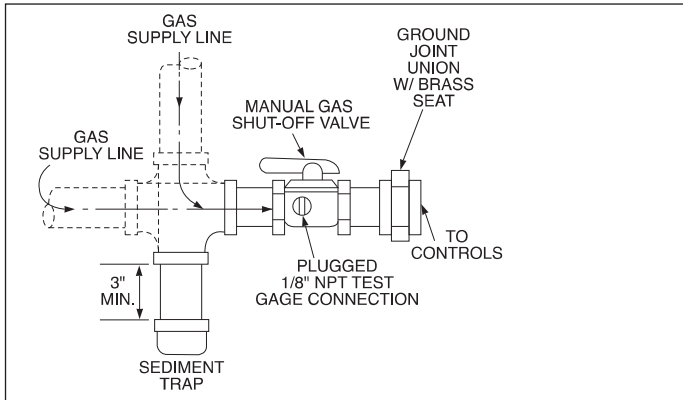

- When Pressure/Leak testing, pressures above 14" W.C. (1/2 psi), close the field installed shut-off valve, disconnect the appliance and its combination gas control from the gas supply line, and plug the supply line before testing. When testing pressures 14" W.C. (1/2 psi) or below, close the manual shut-off valve on the appliance before testing.

<b>mcw</b>		<b>SHOP DRAWING REVIEW</b>	
		PER M/E SPECIFICATIONS SECTIONS	
DATE	PROJECT No.		
<b>2026/04/29</b>	<b>24333-08</b>		
<input type="checkbox"/> NOT REVIEWED	<input checked="" type="checkbox"/> REVIEWED		
<input type="checkbox"/> RESUBMIT	<input type="checkbox"/> REVIEWED AS MODIFIED		
<input type="checkbox"/> NOT SPECIFIED BY MCW, REVIEWED FOR MEP ONLY			
ELECTRICAL REVIEWER:		MECHANICAL REVIEWER:	
<u>R.A.</u>		<u>TT</u>	

# UNIT INSTALLATION

**Table 16.1 - Gas Pipe Capacities - Natural Gas ①**

Pipe Length (ft)	Capacity in MBH by Nominal Pipe Diameter							
	1/2"	3/4"	1"	1 1/4"	1 1/2"	2"	2 1/2"	3"
10	138	287	540	1,113	1,659	3,203	5,103	9,009
20	95	197	371	762	1,145	2,195	3,507	6,195
30	76	159	298	612	917	1,764	2,814	4,977
40	65	135	255	524	784	1,512	2,405	4,253
50	58	120	226	464	695	1,344	2,132	3,770
60	53	109	205	420	630	1,218	1,932	3,423
70	48	100	188	386	580	1,113	1,775	3,150
80	44	93	175	360	540	1,038	1,659	2,930
90	42	87	165	338	506	974	1,554	2,741
100	40	83	155	319	478	921	1,470	2,594
125	35	74	138	282	423	816	1,302	2,300
150	32	66	125	256	384	739	1,176	2,079
175	29	61	114	235	353	680	1,082	1,911
200	27	57	107	219	329	632	1,008	1,785
250	24	50	95	194	291	561	894	1,575

① Gas pipe capacities based on Table 6.2.1 (a) of NFPA 54 for schedule 40 metallic pipe with inlet pressure less than 2 psi, with a pressure drop of 0.3" w.c. and gas specific gravity of 0.60.

**Table 16.2 - Gas Pipe Capacities - Propane Gas ②**

Pipe Length (ft)	Capacity in MBH by Nominal Pipe Diameter							
	1/2"	3/4"	1"	1 1/4"	1 1/2"	2"	2 1/2"	3"
10	291	608	1,150	2,350	3,520	6,790	10,800	19,100
20	200	418	787	1,620	2,420	4,660	7,430	13,100
30	160	336	632	1,300	1,940	3,750	5,970	10,600
40	137	287	541	1,110	1,660	3,210	5,110	9,030
50	122	255	480	985	1,480	2,840	4,530	8,000
60	110	231	434	892	1,340	2,570	4,100	7,250
80	101	212	400	821	1,230	2,370	3,770	6,670
100	94	197	372	763	1,140	2,200	3,510	6,210
125	89	185	349	716	1,070	2,070	3,290	5,820
150	84	175	330	677	1,010	1,950	3,110	5,500
175	74	155	292	600	899	1,730	2,760	4,880
200	67	140	265	543	814	1,570	2,500	4,420
250	62	129	243	500	749	1,440	2,300	4,060

② Gas pipe capacities based on Table 6.3.1(d) of NFPA 54 for schedule 40 metallic pipe with inlet pressure of 11.0" w.c., with a pressure drop of 0.5" w.c. and gas specific gravity of 1.50.

**Table 16.3 - Burner Orifice Sizing and Gas Consumption**

Model Size		Gas Type		Orifice Qty
		Natural ①	Propane ②	
100	Cfh	96.1	40.0	2
	Orifice Drill Size	30	45	
125	Cfh	120.2	50.0	2
	Orifice Drill Size	25	42	
150	Cfh	144.2	60.0	3
	Orifice Drill Size	30	45	
175	Cfh	168.3	70.0	3
	Orifice Drill Size	27	43	
200	Cfh	192.3	80.0	3
	Orifice Drill Size	23	42	
225	Cfh	216.3	90.0	3
	Orifice Drill Size	20	39	
250	Cfh	240.4	100.0	4
	Orifice Drill Size	25	42	
300	Cfh	288.7	120.0	4
	Orifice Drill Size	20	39	
350	Cfh	336.5	140.0	6
	Orifice Drill Size	27	43	
400	Cfh	384.6	160.0	6
	Orifice Drill Size	23	42	
500 ③	Cfh	240.4	100.0	4
	Orifice Drill Size	25	42	
600 ③	Cfh	288.7	120.0	4
	Orifice Drill Size	20	39	
700 ③	Cfh	336.5	140.0	6
	Orifice Drill Size	27	43	
800 ③	Cfh	384.6	160.0	6
	Orifice Drill Size	23	42	
840 ④	Cfh	336.5	140.0	6
	Orifice Drill Size	27	43	
960 ④	Cfh	384.6	160.0	6
	Orifice Drill Size	23	42	

① Based on natural gas properties of 1050 Btu/ft³ and specific gravity of 0.60.

② Based on propane gas properties of 2500 Btu/ft³ and specific gravity of 1.50.

③ Model sizes 500-800 contain 2 furnaces. Values shown are per furnace.

④ Model sizes 840-960 contain 3 furnaces. Values shown are per furnace.

**SHOP DRAWING REVIEW**  
PER M/E SPECIFICATIONS SECTIONS

DATE: **2026/04/29** PROJECT No.: **24333-08**

NOT REVIEWED                       REVIEWED  
 RESUBMIT                               REVIEWED AS MODIFIED  
 NOT SPECIFIED BY MCW, REVIEWED FOR MEP ONLY

ELECTRICAL REVIEWER: R.A.                      MECHANICAL REVIEWER: TT



# UNIT INSTALLATION

## Electrical Connections

**⚠ WARNING**

1. Disconnect power supply before making wiring connections or working on this equipment. Follow all applicable safety procedures to prevent accidental power up. Failure to do so can result in injury or death from electrical shock or moving parts and may cause equipment damage.
2. All appliances must be wired strictly in accordance with wiring diagram furnished with the appliance. Any wiring different from the wiring diagram could result in a hazard to persons and property.
3. Any original factory wiring that requires replacement must be replaced with wiring material having a temperature rating of at least 105°C.
4. Ensure that the supply voltage to the appliance, as indicated on the serial plate, is not 5% greater than rated voltage.

**⚠ AVERTISSEMENT**

1. Débranchez l'alimentation électrique avant d'effectuer des connexions ou de travailler sur l'appareil. Respectez toutes les procédures de sécurité qui s'appliquent pour éviter toute mise en marche accidentelle. Le non-respect de cette directive peut entraîner des blessures ou la mort causées par un choc électrique ou des pièces mobiles, en plus d'endommager l'appareil.
2. Tous les appareils doivent être branchés de manière strictement conforme au diagramme fourni. Tout câblage différent de celui du schéma peut créer des risques de dommages matériels ou de blessures.
3. Tout câblage usine d'origine exigeant un remplacement doit être remplacé par un câble d'indice thermique nominal de 105 °C.
4. Assurez-vous que la tension d'alimentation de l'appareil, comme indiqué sur la plaque de série, n'est pas de 5 % supérieure à la tension nominale.

**⚠ CAUTION**

1. Ensure that the supply voltage to the appliance, as indicated on the serial plate, is not 5% less than the rated voltage.
2. Do not attempt to reuse any mechanical or electrical component which has been wet. Such component must be replaced.

**⚠ ATTENTION**

1. Vérifiez que la tension d'alimentation de l'appareil n'est pas inférieure de plus de 5 % à la tension nominale inscrite sur la plaque de série.
2. Ne tentez pas de réutiliser un composant mécanique ou électrique qui a été mouillé. Ces composants doivent être remplacés.

1. Installation of wiring must conform with local building codes, or in the absence of local codes, with the National Electric Code ANSI/NFPA 70 - Latest Edition. Unit must be electrically grounded in conformance to this code. In Canada, wiring must comply with CSA C22.1, Part 1, Electrical Code.

2. Two copies of the job specific wiring diagram are provided with each unit, one located in the duct furnace electrical junction box and one in the electrical section of the unit located in the blower compartment. Refer to this diagram for all wiring connections.
  3. External electrical connections to be installed include:
    - Supply power (120, 208, 240, 480, or 600 volts).
    - Thermostats, remote monitoring panels, building pressure sensors, time clocks, or any other accessory control devices that may be supplied (24 volts).
- NOTE: If the unit is equipped with a field or factory mounted VFD, make all connections on the access side of the unit.

4. All supply power electrical connections are made in the electrical section of the unit. The low voltage (thermostat and accessory control devices) may be wired to either the electrical section or the duct furnace electrical junction box. Refer to the wiring diagram for the terminal location of all low voltage wiring.
5. Refer to the unit dimensional drawings in this document for the location of the drill locator dimples in the side and bottom of the unit for field drilling the hole for the electrical conduit entry.
6. Control wiring consists of both 24V analog control wiring and for models with Model Digit 12=9, low current digital control signal wiring. To avoid signal interference, the two types should be run in conduit separate from power wiring. The analog control wiring should be shielded at one end of the wiring run. Wiring should be stranded, twisted, and shielded communication wire.
7. The wire gauge must be sized according to the National Electric Code or CSA code based on amp draw and length of run. Refer to Table 18.1 for maximum wire lengths that can be wired between components and the terminal block on the unit based on the wire gauge being used.

**Table 18.1 - 24V and Digital Control Wire Lengths**

Minimum Recommended Wire Gauge	Maximum Distance (feet) from Control Device to Unit	
	24V Control Wiring	Digital Control Wiring
22	n/a	120
20	n/a	200
18	75	300
16	125	500
14	175	n/a

8. FOR UNITS WITH MODEL DIGIT 12=9 (MODINE CONTROL SYSTEM OPTION): For field wiring to the factory terminal strip, the terminal strip connections are designed to clamp down on the wires. To properly connect the wires to the terminal strip:
  - Push the wire into the square hole in the terminal. Press firmly until the screwdriver hits the back stop and opens the terminal (see Figure 19.1).
  - Remove approximately 3/8" of insulation from the end of the wire and push the stripped wire into the oval hole in the terminal.
  - Remove the screwdriver from the wire to make sure that it is correctly clamped in the terminal.
  - Make sure that the terminal clamp is in contact with bare wire (insulation removed).

**SHOP DRAWING REVIEW**

DATE: 2026/04/29

2438-08

NOT REVIEWED

RESUBMIT

NOT SPECIFIED BY MCW, REVIEWED FOR MEP ONLY

REVIEWED

REVIEWED AS MODIFIED

**ELECTRICAL REVIEWER:** \_\_\_\_\_

**MECHANICAL REVIEWER:** \_\_\_\_\_

# UNIT INSTALLATION

**Figure 19.1 - Terminal Strip Wiring (Model Digit 12=9)**

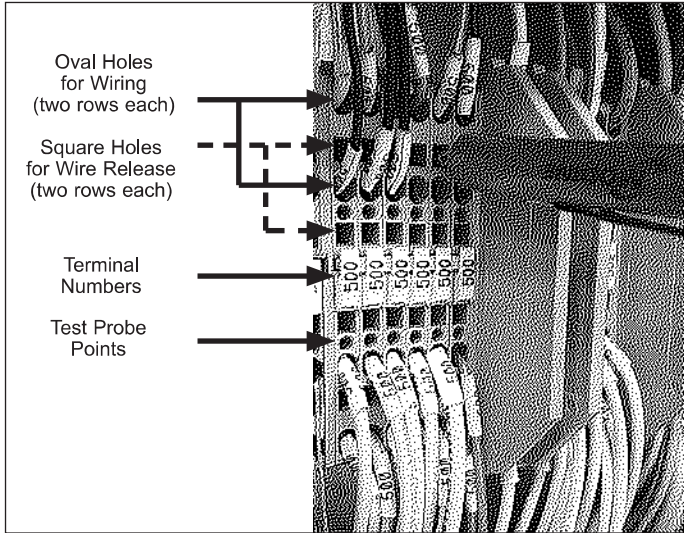

9. Depending on the configuration of the unit controls, there may be sensors that are field installed. Review the unit ordered to verify that the sensors supplied match the configuration of the unit. The following are sensors that may be included for field installation (for installation instructions, refer to the instructions included with the individual sensors):

- **Supply Air Temperature Sensor**  
This sensor is required on all units and is mounted in the supply air ductwork downstream of the unit discharge.
- **Outdoor Air Sensor**  
This sensor is required on all units except 100% return air units. Depending on the unit configuration, the sensor may be duct mounted or remote mounted.
- **Return Air Sensor**  
This sensor is required on all units that have a mixture of outside and return air. The sensor is mounted in the return air ductwork.
- **Space Temperature/Humidity Sensor**  
This sensor is required on all units that have space temperature/humidity reset control.

SHOP DRAWING REVIEW  
PER M/E SPECIFICATIONS SECTIONS  
DATE: 2026/04/29  
24333-08

NOT REVIEWED       REVIEWED

RESUBMIT               REVIEWED AS MODIFIED

NOT SPECIFIED BY MCW, REVIEWED FOR MEP ONLY

**ELECTRICAL REVIEWER: R.A.**      **MECHANICAL REVIEWER: TT**

- **Duct Pressure Sensor**  
This sensor is required on all units that have duct pressure control through variable frequency drive control of the supply air blower.
- **Space CO2 Sensor**  
This sensor is required on all units that have demand based ventilation control based on space CO2 concentration.
- **Duct Mounted Smoke Detector**  
This sensor is mounted in the supply air or return air ductwork.

For further instructions on the above sensor(s), refer to the installation instructions that shipped with the sensor(s).

10. Make sure all multi-voltage components (motors, transformers, etc.) are wired in accordance with the power supply voltage.
11. The power supply to the unit must be protected with a fused or circuit breaker disconnect switch. Refer to the

Factory Mounted Option Locations (Figure 29.1) for the factory mounted disconnect switch location and then review the unit to determine if a factory installed dead front disconnect switch was provided. Accessory field installed disconnect switches should be mounted where required by the National Electric Code as shown in Figure 29.1. For fusible disconnect switches, refer to the Model Identification plate for the fuse size and type.

12. The power supply must be within 5% percent of the voltage rating and each phase must be balanced within 2 percent of each other. If not, advise the utility company.
13. All outdoor electrical connections must be weatherized to prevent moisture from entering the electrical compartment.

**Figure 19.2 - Recommended Accessory Field Installed Disconnect Switch Mounting Locations**

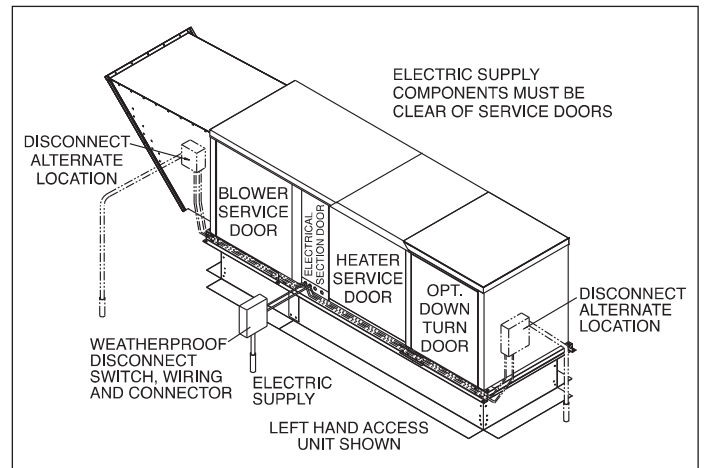

## Evaporative Cooler Installation

For units equipped with an evaporative cooler (Model Digit 22=D), refer to Installation and Service Manual - Evaporative Coolers (Literature 5-588).

### Evaporative Cooler operating conditions.

- Min. Water Pressure: 35 psig (241 kPa)
- Max. Water Pressure: 100 psig (689 kPa)
- Min. Water Temperature: 40 F (4 C)
- Max. Water Temperature: 130 F (54 C)

### Conditions d'utilisation du refroidisseur par évaporation.

- Pression d'eau : 241 kPa (35 psig)
- Pression d'eau : 689 kPa (100 psig)
- Température de l'eau : 4 °C (40 °F)
- Température de l'eau : 54 °C (130 °F)

**Figure 19.3 - Evaporative Cooler (Model Digit 22=D)**

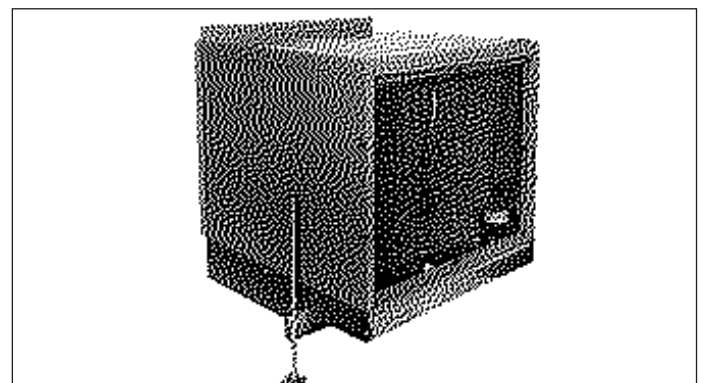

# INSTALLATION

## Models with Optional Cooling Coils

Models with a cooling section can be equipped with a factory installed direct expansion (DX) evaporator or the coil can be field supplied and installed by others. For units equipped with a factory installed DX coil (Digit 23 = 2 or 3), refer to Literature 5-585.

The cooling section includes a full coverage, 3-way sloping 409 stainless steel drain pan to remove condensate from coil headers, thermal expansion valves, and refrigerant piping. Insulation is standard on outdoor units and optional on indoor units. The cabinet includes two doors, a removable upper door for service access to the coil once the plumbing has been installed and a lower door which includes a factory supplied 1" stubbed drain connection to the exterior of the cabinet. Field connections for coil inlet and outlet piping can be made through the cabinet corner post or back of the unit. The cooling section duct transition includes 1.5" (3.8 cm) flanges for fastening the sides of the coil. The bottom duct transition is angled to remove any condensation that may be entrained in the supply air stream.

For field supplied coils, do not exceed the maximum coil dimensions listed in Literature 82-135. The dimensions listed are for the maximum coil dimensions. If the coil supplied is smaller than the listed dimensions, field supplied blank off plates are required to prevent air bypass around the coil. The coil is supported by two 14 gauge support rails which contain mounting provisions for fastening 4" (10.2 cm), 5" (12.7 cm), 6" (15.2 cm), 7.5" (19.1 cm), 10" (25.4 cm) deep coils.

Figure 19.1 -

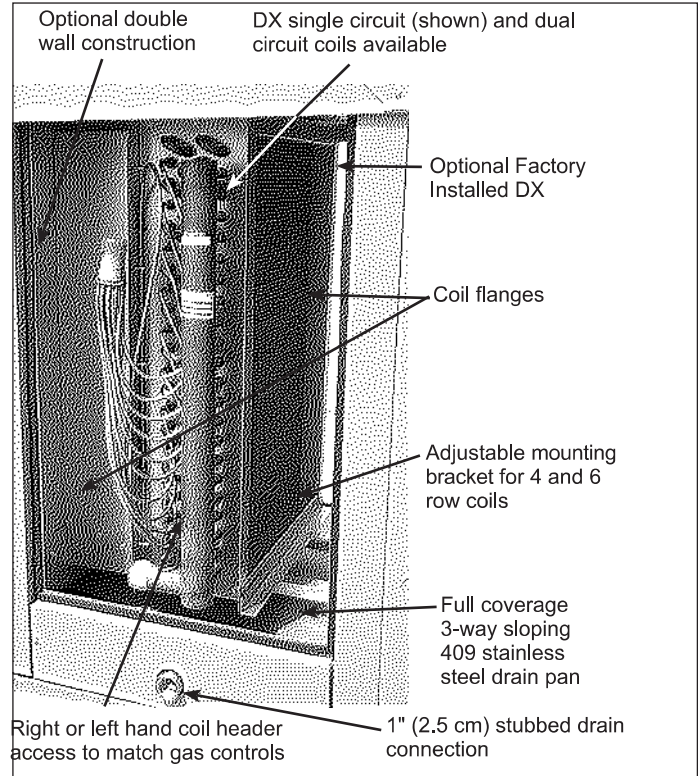

	<b>SHOP DRAWING REVIEW</b> PER M/E SPECIFICATIONS SECTIONS	
	DATE <b>2026/04/29</b>	PROJECT No. <b>24333-08</b>
<input type="checkbox"/> NOT REVIEWED	<input checked="" type="checkbox"/> REVIEWED	
<input type="checkbox"/> RESUBMIT	<input type="checkbox"/> REVIEWED AS MODIFIED	
<input type="checkbox"/> NOT SPECIFIED BY MCW, REVIEWED FOR MEP ONLY		
ELECTRICAL REVIEWER: <u>R.A.</u>	MECHANICAL REVIEWER: <u>TT</u>	

# INSTALLATION

## Condensate Drain Pan Trap

The condensate drain line needs to include a field supplied P-trap immediately downstream of the connection to the unit. This trap should extend at least 2" (5 cm) below the connection to prevent air pressure from forcing air into the unit. The trap should be primed with a water/glycol solution to prevent freezing.

## Direct Expansion (DX) Piping

DX piping must conform to local codes. Factory installed DX evaporators are shipped uncharged with a nozzle installed in the distributor. Inspect the refrigerant distributor and verify that the nozzle is in place before brazing piping.

**Table 21.1 - Cooling Coil Performance Limits**

Cooling Type	Model Size (Digits 4-6)	Min CFM	Single Circuit		Dual Circuit		Max Cooling (Tons) R32 <sup>②</sup>	Max Cooling (Tons) R454B <sup>②</sup>
			Max CFM <sup>①</sup>	Area (ft <sup>2</sup> )	Max CFM <sup>①</sup>	Area (ft <sup>2</sup> )		
DX	100	802 <sup>④</sup>	2,206	4.01	2,048	3.72	11.7	12.1
	125	937						
	150	1,125	2,521	4.58	2,416	4.39	13.6	14.0
	175	1,312						
	200	1,500	3,352	6.09	3,165	5.76	18.8	19.0
	225	1,687						
	250	1,875	3,724	6.77	3,538	6.43	21.2	21.3
	300	2,250						
	350	2,625	5,214	9.48	4,996	9.08	30.0	29.2
	400	3,000						

- ① Based on 550 feet per minute (FPM) coil face velocity.
- ② Based on 95°F/75°F Entering Dry Bulb/Wet Bulb.
- ④ Model Size 100 minimum CFM for DX Dual Circuit is 745.

**SHOP DRAWING REVIEW**  
PER M/E SPECIFICATIONS SECTIONS

DATE: **2026/04/29** PROJECT No.: **24333-08**

NOT REVIEWED                       REVIEWED  
 RESUBMIT                               REVIEWED AS MODIFIED  
 NOT SPECIFIED BY MCW, REVIEWED FOR MEP ONLY

ELECTRICAL REVIEWER: R.A.                      MECHANICAL REVIEWER: TT

# START-UP PROCEDURE

## Start-Up Procedure

### IMPORTANT

1. To prevent premature heat exchanger failure, observe heat exchanger tubes by looking at the heat exchanger through the field installed access openings in connecting ductwork or the unit access doors where viewing the heat exchanger is possible. If the bottom of the tubes become red while blower and duct furnace are in operation, check to be sure the blower has been set to the proper rpm for the application. Refer to page 26 for Blower Adjustments.
2. Start up and adjustment procedures, installation, and service of these appliances must be performed by a qualified installation and service agency.

### IMPORTANT

1. Pour éviter la défaillance prématurée de l'échangeur de chaleur, examinez les tubes de l'échangeur de chaleur en le regardant à travers les ouvertures d'accès installées sur les lieux lors de la connexion des tuyaux ou les portes d'accès à l'unité où il est possible de voir l'échangeur de chaleur. Si le bas des tubes devient rouge lorsque la soufflante et la chaudière canalisée sont en marche, vérifiez que le régime de la soufflante est approprié pour l'application. Pour le réglage de la soufflante, reportez-vous à la page 26.
2. Les procédures de démarrage et de réglage, l'installation et le service de ces appareils doivent être confiés à un centre d'installation et de service qualifié.

Refer to page 60 for the Start-up Checklist.

1. Turn off power to the unit at the disconnect switch. Check that fuses or circuit breakers are in place and sized correctly. Turn all hand gas valves to the "OFF" position.
2. Remove the blower exterior panels and open the electrical compartment door.
3. Check that the supply voltage matches the unit supply voltage listed on the Model Identification plate. Verify that all wiring is secure and properly protected. Trace circuits to insure that the unit has been wired according to the wiring diagram.
4. Check to insure that the venting system is installed and free from obstructions.
5. Check to see that there are no obstructions to the intake and discharge of the unit.
6. Check the belt tension and sheave alignment. Refer to Blower Adjustments for proper belt tension.
7. Check bearings for proper lubrication. For units provided with pillow block bearings (See Model Nomenclature), refer to Lubrication Recommendations for requirements.
8. Check to make sure that all filters are in place and that they are installed properly according to direction of air flow.
9. Perform a visual inspection of the unit to make sure no damage has occurred during installation.
10. Turn on power to the unit at the disconnect switch. Check to insure that the voltage between duct furnace electrical box terminals 1 and 2 is 24V.
11. Check the thermostat, ignition control, gas valve, and supply fan blower motor for electrical operation. If these do not function, recheck the wiring diagram. Check to insure that none of the Control Options have tripped.

12. For units with a return air damper, the return air damper linkage needs to be adjusted. Refer to Damper Linkage Adjustment.
13. Check to make sure that the damper opens properly without binding.
14. Check the blower wheel for proper direction of rotation when compared to the air flow direction arrow on the blower housing. Blower wheel rotation, not air movement, must be checked as some air will be delivered through the duct furnace with the blower wheel running backwards.
15. Check the blower speed (rpm). Refer to Blower Adjustments for modification.
16. Check the motor speed (rpm).
17. Check the motor voltage. On three phase systems, check to make sure all legs are in balance.
18. Check the motor amp draw to make sure it does not exceed the motor nameplate rating. On three phase systems, check all legs to insure system is balanced.
19. Recheck the gas supply pressure at the field installed manual shut-off valve. The minimum inlet pressure should be 6" W.C. on natural gas and 11" W.C. on propane gas. The maximum inlet pressure for either gas is 14" W.C. If inlet pressure exceeds 14" W.C., a gas pressure regulator must be added upstream of the combination gas valve.
20. Open the field installed manual gas shut-off valve.
21. Open the manual main gas valve on the combination gas valve. Call for heat with the thermostat and allow the pilot to light for intermittent pilot ignition. If the pilot does not light, purge the pilot line. If air purging is required, disconnect the pilot line at outlet of pilot valve. In no case should the line be purged into heat exchanger. Check the pilot flame length (See Pilot Flame Adjustment).
22. Once the pilot has been established, check to make sure that the main gas valve opens. Check the manifold gas pressure (See Main Gas Adjustment) and flame length (See Air Shutter Adjustment) while the supply fan blower is operating.
23. Check to insure that gas controls sequence properly (See Control Operating Sequence). Verify if the unit has any additional control devices and set according to the instructions in the Control Options.
24. Once proper operation of the unit has been verified, remove any jumper wires that were required for testing.
25. Close the electrical compartment door.
26. Replace all exterior panels.

	<b>SHOP DRAWING REVIEW</b>	
	PER M/E SPECIFICATIONS SECTIONS	
DATE	PROJECT No.	
<b>2026/04/29</b>	<b>24333-08</b>	
<input type="checkbox"/> NOT REVIEWED	<input checked="" type="checkbox"/> REVIEWED	
<input type="checkbox"/> RESUBMIT	<input type="checkbox"/> REVIEWED AS MODIFIED	
<input type="checkbox"/> NOT SPECIFIED BY MCW, REVIEWED FOR MEP ONLY		
ELECTRICAL REVIEWER:	MECHANICAL REVIEWER:	
<u>R.A.</u>	<u>TT</u>	

# START-UP PROCEDURE

## Pilot Burner Adjustment

The pilot burner is orificed to burn properly with an inlet pressure of 6-7" W.C. on natural gas and 11-14" W.C. on propane gas. Final adjustment must be made after installation. If the pilot flame is too long or large, it may cause soot and/or impinge on the heat exchanger causing failure. If the pilot flame is too short, it may cause poor ignition or result in the controls not opening the combination gas control. A short flame can be caused by a dirty pilot orifice. The pilot flame should be observed periodically to assure trouble-free operation.

### To Adjust the Pilot Flame

1. Create a call for heat from the thermostat.
2. Remove the cap from the pilot adjustment screw. For location, see the combination gas control literature supplied with unit.
3. Adjust the pilot length by turning the screw in or out to achieve a soft steady flame 3/4" to 1" long and encompassing 3/8"-1/2" of the tip of the flame sensing rod (See Figure 23.1).
4. Replace the cap from the pilot adjustment screw.

**Figure 23.1 - Correct Pilot Flame**

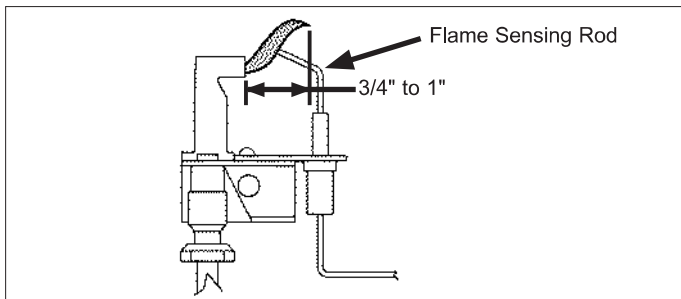

	<b>SHOP DRAWING REVIEW</b> PER M/E SPECIFICATIONS SECTIONS
DATE <b>2026/04/29</b>	PROJECT No. <b>24333-08</b>
<input type="checkbox"/> NOT REVIEWED	<input checked="" type="checkbox"/> REVIEWED
<input type="checkbox"/> RESUBMIT	<input type="checkbox"/> REVIEWED AS MODIFIED
<input type="checkbox"/> NOT SPECIFIED BY MCW, REVIEWED FOR MEP ONLY	
ELECTRICAL REVIEWER: <u>R.A.</u>	MECHANICAL REVIEWER: <u>TT</u>

# START-UP PROCEDURE

## Main Burner Adjustment

The gas pressure regulator (integral to the combination gas control) is adjusted at the factory for average gas conditions. It is important that gas be supplied to the duct furnace in accordance with the input rating on the serial plate. Actual input should be checked and necessary adjustments made after the duct furnace is installed. Over-firing, a result of too high an input, reduces the life of the appliance and increases maintenance. Under no circumstances should the input exceed that shown on the serial plate.

## Check/Adjust Pressure at the Combination Gas Valve

This section applies to all units, regardless of gas control type.

1. Turn the field installed manual shut-off valve to "OFF".
2. Remove the 1/8" pipe plug in the pipe tee or gas valve and attach a U-tube type water manometer which is at least 12" high and capable of reading to 0.1" W.C. See Figure 24.1.
3. Turn the field installed manual gas shut-off valve to "ON".

Figure 24.1 - Checking Gas Pressure with Manometer

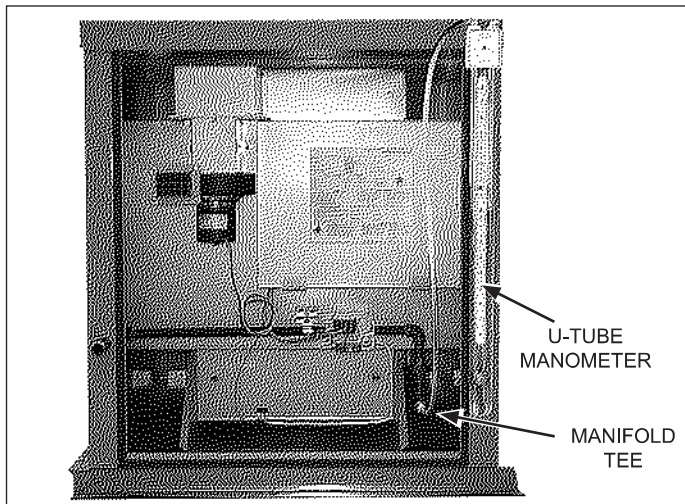

4. Create a high fire call for heat from the thermostat.
5. Determine the correct high fire manifold pressure, which depends on gas type and gas control type. Review the furnace Model Digit 11 and 12 (not the system model number) and adjust the main gas pressure regulator spring to achieve the proper manifold pressure as shown in Table 24.1. For location of regulator adjustment, refer to the combination gas control literature supplied with the unit.

Table 24.1 - Manifold Gas Pressure - Main Valve

Furnace Model Digit 11	Furnace Model Digit 12	Manifold Pressure
N (Natural)	1, 2, 4, 7	3.5"
	9 ①	4.0"
P (Propane)	1, 2, 4, 7	10.0"
	9 ①	10.5"

① For units with Model Digit 12=9 and multiple furnaces, only one furnace will be Model Digit 12=9, the additional furnaces will be Model Digit 12=2, therefore pressures will be different for those furnaces.

6. If the unit has Electronic Modulation gas controls (Model Identification Digit 12=4, 7, or 9), skip steps 7 through 9 in this section and proceed to the next section "Check/Adjust Pressure for the Modulating Valve", otherwise continue to the next step.

7. After adjustment, move the field installed manual shut-off valve to the "OFF" position, remove the manometer, and replace the 1/8" pipe plug.
8. After the plug is in place, move the field installed manual shut-off valve to the "ON" position and recheck pipe plugs for gas leaks with soap solution.
9. Proceed to the section "Air Shutter Adjustment".

## Check/Adjust Pressure for the Modulating Valve

This section only applies to units with Electronic Modulation gas controls (Model Identification Digit 12=4, 7, or 9). Refer to the appropriate instructions for the valve type on the unit.

### For Units with Model Digit 12=4 or 7:

The low fire gas pressure needs to be adjusted. This needs to be repeated on each furnace in multiple furnace units. Using Figure 24.2 for item locations, this is accomplished as follows:

1. Disconnect power.
2. Remove all wires from Maxitrol Amplifier terminal "3" or duct furnace terminal "43" (if available).
3. Turn on power at the disconnect switch.
4. Remove the cover plate (2), maximum adjustment screw (4), spring (5), and plunger (8). A small magnet is useful for this purpose. CAUTION - The plunger is a precision part. Handle carefully to avoid chipping or picking up grease and dirt. Do not lubricate.
5. Using minimum adjusting screw (9), adjust low fire manifold pressure to 0.56" W.C. for natural gas and 1.6" W.C. for propane gas.
6. Replace plunger and spring retainer, spring, and maximum adjusting screw in proper order.
7. Using maximum adjustment screw (4), adjust high fire manifold pressure to 3.5" W.C. for natural gas and 10" W.C. for propane gas.
9. Disconnect power.
9. Replace cover plate (2) and re-install all wires from Maxitrol amplifier terminal "3" or duct furnace terminal "43".
10. After adjustment, move the field installed manual shut-off valve to the "OFF" position, remove the manometer, and replace the 1/8" pipe plug.

**MEW** (Merrill Equipment Warehouse) stamp with handwritten text: "DATE: 2026/04/29", "PROJECT No: 24333-08".

Handwritten notes: "BY HO OR Aiming or Diving", "PER THE SPECIFICATIONS SECTIONS".

Checklist items:

- NOT REVIEWED
- REVIEWED
- RESUBMIT
- REVIEWED AS MODIFIED
- NO SPECIFIED BY MEW - REVIEWED FOR MEW ONLY

Handwritten initials: "ELECTRONIC REVIEWER: R.A.", "MECHANICAL REVIEWER: TT".

(continued next page)

Figure 24.2 - Maxitrol Modulating Valve Adjustments

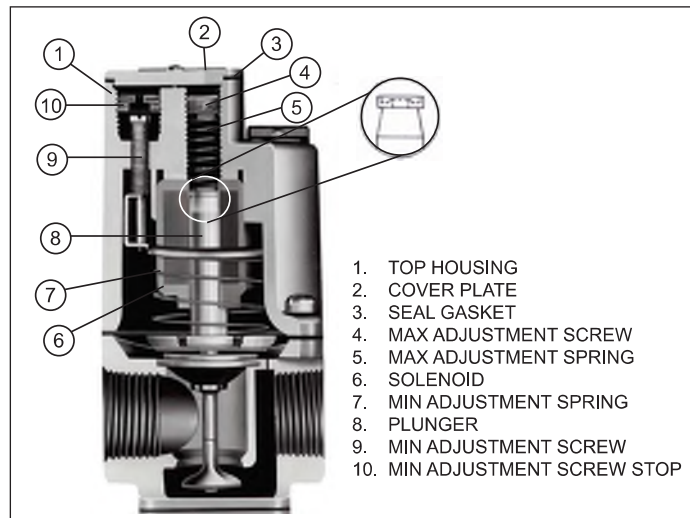

# START-UP PROCEDURE

## Check/Adjust Pressure for the Modulating Valve (continued)

1. After the plug is in place, move the field installed manual shut-off valve to the "ON" position and recheck pipe plugs for gas leaks with soap solution.
2. Proceed to the section "Air Shutter Adjustment".

### For Units with Model Digit 12=9:

The high fire gas pressure needs to be adjusted first, followed by the low gas pressure. For multiple furnace units, this is only required on the duct furnace that has the modulating valve (Model Digit 12=9). This is accomplished as follows:

1. Verify the main valve (valve before the modulating valve) outlet pressure has been set to 4.0-4.5" W.C. for natural gas or 10.5-11.0" W.C. for propane gas per instructions and Table 23.1 on the previous page. For multiple furnace units, the furnaces without the modulating valves are to remain at 3.5" W.C. for natural gas or 10.0" W.C. for propane gas. For location of regulator adjustment, refer to the combination gas control literature supplied with the unit.
2. The Maxitrol EXA modulating valve series has a cover secured with two screws that must be removed. Once removed, there are a bank of (3) DIP switches and two buttons and a communication LED for the user interface as shown in Figure 25.1.
3. Verify that the DIP switches are properly set to the "OFF" position for switches 1 and 3 and "ON" for switch 2. (The 3rd Dip Switch position may not be included.)
4. Adjust the High Fire Setting as follows:
  - a. Enable the unit controls and create a call for heat.
  - b. Press and hold Button #1 on the modulating valve until the LED lights solid red, then release.
  - c. With the valve now in the high fire setting mode, confirm or adjust the high fire manifold pressure to be 3.5" W.C. for natural gas (10.0" W.C. for propane). If the pressure needs to be adjusted, press or hold Button #1 to increase gas flow and press or hold Button #2 to decrease gas flow.
  - d. If 3.5" W.C. cannot be attained, recheck the inlet gas pressure as described previously. After addressing any issues, if 3.5" W.C. for natural gas (10.0" W.C. for propane) still cannot be attained, step the valve closed using button #2 to the point where manifold pressure begins to be impacted. If the pressure at that point is less than 3.3" W.C. for natural gas (9.5" for propane), recheck your inlet pressure with the unit operating and adjust as required.
  - e. Save the setting by simultaneously holding Buttons #1 and #2 until the LED turns OFF. If this is not performed within 5 minutes, the control will default to the previously saved settings and return to normal operating mode.
5. Adjust the Low Fire Setting as follows:
  - a. Press and hold Button #2 on the modulating valve until the LED light blinks red, then release.
  - b. With the valve now in the low fire setting mode, confirm or adjust the low fire manifold pressure to be no less than the minimum of 0.56"W.C. for natural gas or 1.6"W.C. for propane. If the pressure needs to be adjusted:
  - c. Press or hold Button #1 to increase gas flow and #2 to decrease gas flow. It is best to push and release button #2 to single step the valve to the minimum manifold

pressure. Holding the button is likely to cause the valve to close too far and lose flame.

- d. Save the setting by simultaneously holding Buttons #1 and #2 until the LED turns OFF. If this is not performed within 5 minutes, the control will default to the previously saved settings and return to normal operating mode.
6. Once the setting of the modulating valve has been completed, replace the valve cover removed earlier.
7. Move the field installed manual shut-off valve to the "OFF" position, remove the manometer, and replace the 1/8" pipe plug.
8. After the plug is in place, move the field installed manual shut-off valve to the "ON" position and recheck the pipe plug for gas leaks with soap solution.
9. Proceed to the section "Air Shutter Adjustment".

**Figure 25.1 - Proceed to the section "Air Shutter Adjustment". Maxitrol EXA Modulating Valve**

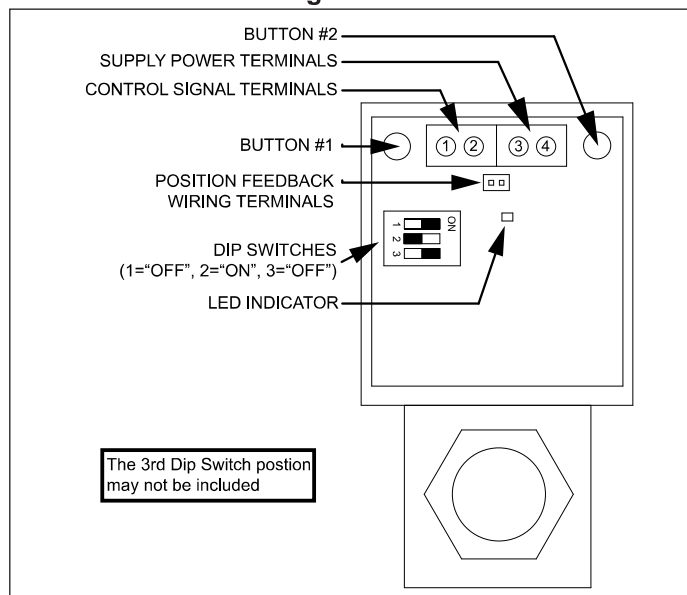

## Air Shutter Adjustment

Proper operation provides a soft blue flame with a well-defined inner core. A lack of primary air will reveal soft yellow-tipped flames. Excess primary air produces short, well-defined flames with a tendency to lift off the burner ports. For both natural and propane gas, the air shutters can be adjusted to control burner flame height. The air shutters can be accessed by reaching behind the manifold tee in Figure 24.1. The larger models may require the removal of the manifold (see Manifold Assembly Removal).

Adjusting the primary combustion air is achieved by resetting the primary air shutters (See Figure 56.1). Prior to flame adjustment, operate duct furnace for 10 minutes to stabilize the main burner flame. The burner flame can be viewed after loosening and pushing aside the designation disc on the side of the burner box.

1. To increase primary air, loosen the air shutter set screws and move the air shutters closer to the manifold until the yellow tipped flames disappear and a clean blue flame with a well defined inner cone appears.
2. To decrease primary air, move the air shutters away from the manifolds until flames no longer lift from burner ports, but being careful not to cause yellow tipping.
3. Re-tighten set screws after adjustment.

**MEW SHOP DRAWING REVIEW**  
 PER M/E SPECIFICATIONS SECTIONS  
 DATE: 2026/04/29 PROJECT No: 24333-08  
 NOT REVIEWED  REVIEWED  
 RESUBMIT  REVIEWED AS MODIFIED  
 NOT SPECIFIED BY MEW, REVIEWED FOR MEP ONLY  
 ELECTRICAL REVIEWER: R.A. MECHANICAL REVIEWER: IT

# START-UP PROCEDURE

## Blower Adjustments

All belt drive supply fan speed adjustments can be made with the adjustable sheave on the blower motor as follows:

1. Refer to page 43 to determine correct blower speed according to job requirements, then proceed to the next step.
2. Turn off power to the unit at the disconnect switch. If equipped with gas heat option, turn all hand gas valves to the "OFF" position.
3. Loosen the belt tension and remove the belt.
4. On the motor sheave, loosen the set screw on the side away from the motor (see Figure 26.1).

**Figure 26.1 - Motor Sheave Adjustment**

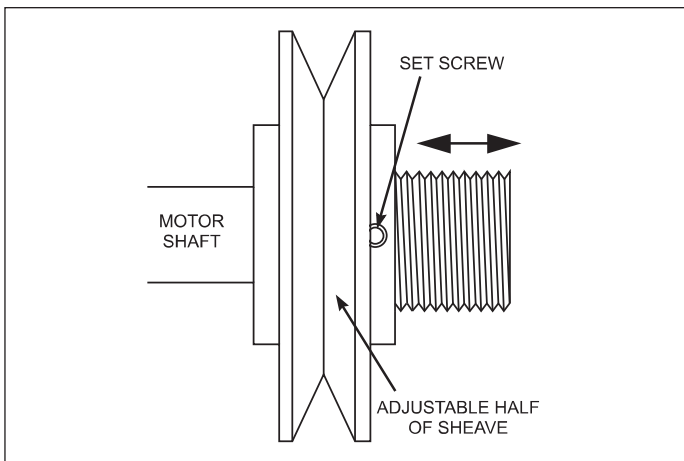

5. Turn outer side of motor sheave clockwise until motor sheave is fully closed.
6. From fully closed position, turn outer side of motor sheave counterclockwise until the proper number of turns open are achieved. Turns should be done in half-turns (180° rotations). Each half turn results in a change of blower speed and air volume of approximately 2.5-5%. Adjusting the half of the sheave inward increases blower speed, adjusting outward decreases blower speed.
7. Tighten the set screw on the flat portion of the motor shaft.
8. Replace the belt and verify that the belts are aligned in the sheave grooves properly and are not angled from sheave to sheave.

**Figure 26.2 - Belt Tension Adjustment**

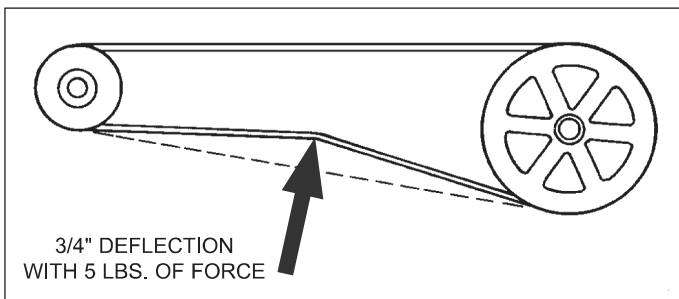

9. Retighten motor base. Motor base should be shifted for proper belt tension which is 3/4" deflection with about 5 lbs. of force. Refer to Figure 26.2.
10. Turn on power to the unit and initiate blower motor operation. Do not fire gas controls until blower adjustment has been made or unit may cycle on high limit control.

11. Check the motor amps to ensure the maximum motor amp rating is not exceeded. Verify airflow volume and repeat steps above for further adjustment.
12. If equipped with gas heat, turn on the gas and initiate burner operation.
13. Verify the temperature rise and supply air temperature of the heating section do not fall outside the range or exceed the maximums shown in Table 37.1.
14. After 24 hours of operation, retighten the setscrews to the torque listed in the owners manual on the bearing, sheave, and blower wheel to avoid damage to the unit.

## Lubrication Recommendations

The blower can be provided with either spider or pillow block bearings. Spider bearings are permanently lubricated and do not require lubrication. Pillow block bearings are shipped greased from the factory but will require lubrication. The bearings should be checked and lubricated before each heating season but a more frequent lubrication schedule may be required based on the environment in which the unit is installed, and the frequency

ended. **SHOP DRAWING REVIEW**  
 PER M/E SPECIFICATIONS SECTIONS  
**PROJECT No. 24399-08**  
**DATE 2026/04/29**

**Damper Linkage Adjustment**

If the unit is provided with a return air damper to prevent shipping damage, the return air damper linkage is disconnected and the damper is closed. Before opening the unit, the fresh and return air dampers must be connected. This is accomplished by the following:

**NOT SPECIFIED BY MCW, REVIEWED FOR MEP ONLY**  
 **ELECTRICAL REVIEWER:**  
 **MECHANICAL REVIEWER:**

1. The damper actuator should be de-energized and the fresh air damper in a fully closed position.
2. **A** Open the return air damper in a fully open position.
3. Slide the connecting rod into the ball joint on the blade arm with the return air damper fully open. See Figure 26.3.
4. Tighten the 5/16" hex head screw on the ball joint.

**Figure 26.3 - Damper Linkage Adjustment**

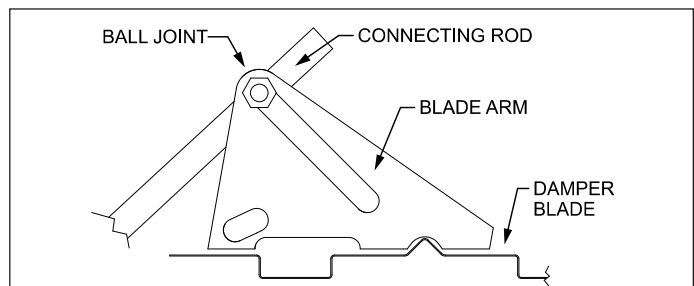

## Furnace Control Operating Sequence

### IMPORTANT

To prevent premature heat exchanger failure, with all control systems, a blower starting mechanism must be provided so that the blower is running or energized within 45 seconds of the gas control operation.

### IMPORTANT

Pour éviter la panne prématurée de l'échangeur thermique, avec tous les systèmes de commande, un mécanisme de démarrage de la soufflerie doit être fourni pour que la soufflerie démarre dans les 45 secondes qui suivent l'activation de la commande de gaz.

# START-UP PROCEDURE

Furnaces are supplied with intermittent pilot systems with continuous retry, which both the main burner and pilot burner are turned off 100% when the thermostat is satisfied.

Control Options (see page 30) could change the listed sequence of operation for the unit based on their function. The descriptions given below are for the basic duct furnace.

## Single Furnace Controls

Single furnace units (Model Digits 4-6=100 through 400) are offered with different types of gas control:

- **Staged Control (Model Digit 12=1 or 2):** These furnaces utilize a single- or two-stage combination gas valve, an ignition control, and a low voltage thermostat.
- **Electronic Modulating Control (Model Digit 12=4 or 7):** These furnaces utilize a single-stage combination gas valve, an electronic modulating gas valve, a modulating amplifier, an ignition control, and one of the following:
  - Modulating room thermostat
  - Modulating duct thermostat with remote temperature set point adjuster
  - Building Management System (BMS) signal by others (an inverted signal where 0VDC is high fire and 10VDC is low fire).
- **Electronic Modulating Control with Modine Control System (Model Digit 12=9):** These furnaces utilize a single-stage combination gas valve, an electronic modulating gas valve, a programmable microprocessor based controller, an ignition control, and different sensors depending on the application, but most commonly include:
  - A duct temperature sensor
  - A space temperature sensor
  - There is also BMS integration capability for BACnet or LonWorks protocol systems.

The control operating sequence for all furnaces is as follows:

1. The thermostat calls for heat or is enabled by the BMS.
2. The power exhauster relay is energized starting the power exhauster motor. Once the motor has reached full speed, the differential pressure switch closes. The power exhauster pre-purge time delay relay then closes after 20 to 40 seconds and energizes the gas control circuit.
3. The pilot valve opens and the spark igniter sparks in an attempt to light the pilot. The system will attempt to light the pilot for 70 seconds. If the pilot is not sensed for any reason, the ignition control will wait for approximately six minutes with the combination gas control closed and no spark. After six minutes, the cycle will begin again. After three cycles, some ignition controllers lockout for approximately one hour before the cycle begins again. This will continue indefinitely until the pilot flame is sensed or power is interrupted to the system.
4. Once the pilot is lit, the flame sensor proves the pilot and stops the spark igniter from sparking.
5. The main gas valve is opened and the main burner is controlled as follows:
  - a. **Single-Stage Furnaces (Model Digit 12=1):** The main burner is lit to 100% full fire.
  - b. **Two-Stage Furnaces (Model Digit 12=2):** The main burner is lit to 50% fire. If the temperature at the thermostat continues to fall, the thermostat will call for high stage heat and the main burner is lit to 100% full fire.

- c. **Modulating Room or Duct Thermostat (Model Digit 12=4):** The main gas valve is opened 100% and the burner firing rate is modulated between 40% and 100% full fire. A resistance signal (8000 to 12000 ohms) in the thermostat is converted by the modulating amplifier to an inverted DC voltage (between 0VDC for high fire to 12 VDC for low fire) and applied to the modulating gas valve to control the gas flow to the main burner.

**Note:** When modulating duct sensing is utilized, a room override thermostat can be added. When the room override calls for heat, the burner modulates to full fire operation until the room override is satisfied. The unit then reverts back to duct sensing control. When equipped with both, either the duct sensor or the room override thermostat can call for heat.

- d. **BMS Signal (Model Digit 12=7):** The main gas valve is opened 100% and the burner firing rate is modulated between 40% and 100% full fire. A BMS 0-10VDC signal (inverted, such that 0 VDC is high fire and 10 VDC is low fire) is converted by the signal conditioner/modulating amplifier into an inverted DC voltage (between 0VDC for high fire to 12 VDC for low fire) and applied to the modulating gas valve to control the gas flow to the main burner. The signal conditioner can accept a 0-10 VDC signal when all the dip switches are in the "OFF" position.

**Note:** For further information regarding the operation of any of the electronic modulating system options above, consult the literature provided with the unit.

- e. **Modulating with Modine Control System (Model Digit 12=9):** The main gas valve is opened 100% and the burner firing rate is modulated between 40% and 100% full fire. Heating demand is determined by the Modine Control System through a comparison of the supply air or space temperature to setpoint and a DC voltage (between 2VDC for low fire to 10 VDC for high fire) is applied to the modulating gas valve to control the gas flow to the main burner.

**Note:** Typically the temperature control is via supply air with the space sensor used to reset the supply air temperature setpoint. For additional information, refer to the Modine Control System Manual, literature #74-510 that shipped with the unit.

6. If the unit was provided with a time delay relay, the blower starts after 30 to 45 seconds.
7. Once the temperature is satisfied, both the main and pilot valves close 100%. Blower operation may or may not continue, depending on application.

	<b>SHOP DRAWING REVIEW</b> PER M/E SPECIFICATIONS SECTIONS
DATE <b>2026/04/29</b>	PROJECT No. <b>24333-08</b>
<input type="checkbox"/> NOT REVIEWED	<input checked="" type="checkbox"/> REVIEWED
<input type="checkbox"/> RESUBMIT	<input type="checkbox"/> REVIEWED AS MODIFIED
<input type="checkbox"/> NOT SPECIFIED BY MCW, REVIEWED FOR MEP ONLY	
ELECTRICAL REVIEWER: <u>R.A.</u>	MECHANICAL REVIEWER: <u>TT</u>

# START-UP PROCEDURE

## Multiple Furnace Controls

Multiple furnace units are available as two furnace units (Model Digits 4-6=500 through 800) and three furnace units (Model Digits 4-6=840 or 960) and with different types of gas control:

- **Staged Control (Model Digit 12=1):** For control of multiple staged furnaces, each furnace would be individually controlled. Refer to the section for Single Furnace Controls, Staged Control (Model Digit 12=1).
  - Two furnace units would be controlled as 2-stage (50%/50%).
  - Three furnace units can be controlled as 3-stage (33%/33%/33%) or 2-stage (33%/67%).
- **Electronic Modulating Control (Model Digit 12=4):** For control of multiple electronic modulating furnaces, one furnace is the Primary furnace featuring a modulating amplifier capable of driving modulating gas valves on Secondary furnaces. Because all valves are driven by one amplifier, all valves modulate at the same rate, from 40% to 100% full fire. Refer to the section for Single Furnace Controls, Electronic Modulating Gas Controls (Digit 12=4).
- **Electronic Modulating Control (Model Digit 12=7):** For control of multiple electronic modulation furnaces for BMS control (0-10VDC control signal), each furnace would be individually controlled. Refer to the section for Single Furnace Controls, Electronic Modulation Control (Model Digit 12=7).
- **Modulating with Modine Control System (Model Digit 12=9):** For control of multiple furnaces, one furnace features a modulating gas valve while additional furnaces are two stage furnaces. The Modine Control system seamlessly stages furnaces and modulates the primary furnace based on demand.

## Variable Air Volume Applications

Units may be supplied with field installed variable frequency drives for applications where variable air volume is required. The minimum air flow may be reduced to as low as 30% of the full speed air flow, but not lower than the minimum airflow listed in Table 28.1 and Table 37.1, unless certain conditions are followed. Refer to the following section titled "Extended VAV Airflow Limits" for additional information.

To determine the actual minimum allowable airflow, all unit selections must be performed with the AccuSpec configuration software. Within AccuSpec, multiple variable frequency drive speed control changeover options are available, which include these common selections:

- Two speed which may be controlled by a manual high/low switch which may be factory mounted on the control panel or shipped loose for field installation or by exhaust fan interlocks.
- Building management control which allows for an external signal of 0-10VDC to adjust the unit airflow.

Additional options are available when the unit is configured with the Modine Control System option (Model Digit 12=9).

## Extended VAV Airflow Limits

If certain conditions are followed, the allowable minimum CFM of the system can be extended to:

75% of the minimum listed CFM in Table 37.1 for high air temperature rise units (Model Digit 10=H)

66% of the minimum listed CFM in Table 37.1 for low air temperature rise units (Model Digit 10=L).

Refer to Table 28.1 for a summary of the reduced minimum airflows, indicated in the column "Extended Range". To allow

the reduced airflows, the unit must be applied as follows:

The unit has 2-stage or modulating gas controls.

The unit is provided with a discharge air thermostat.

The system does not include a room thermostat. Exception: See note below for units equipped with the Modine Control System option (Model Digit 12=9).

The discharge air thermostat will prevent the unit from firing above the allowable 100°F rise when the unit is at or above the minimum CFM by monitoring the discharge air and going to low fire. A room thermostat, because it is located remote from the unit, could cause the unit to over-fire.

Note for units equipped with the Modine Control System option (Model Digit 12=9): A space temperature sensor (Carel pAD) is permitted, as a call for heating from the space results in a reset of the supply air temperature setpoint that will still maintain a supply temperature that is at or below the maximum allowable discharge air temperature.

**Table 28.1 - Extended Range VAV Minimum Airflow**

Input Rating (Digit 4-6)	Minimum Airflow (CFM)			
	High ATR (Digit 10=H)		Low ATR (Digit 10=L)	
	Standard	Extended Range ①	Standard	Extended Range ②
100	750	563	1,250	825
125	938	703	1,563	1,031
150	1,125	844	1,875	1,238
175	1,313	984	2,188	1,444
200	1,500	1,125	2,500	1,650
225	1,688	1,266	2,813	1,856
250	1,875	1,406	3,125	2,063
300	2,250	1,688	3,750	2,475
350	2,625	1,969	4,375	2,888
400	3,000	2,250	5,000	3,300
500	-	-	3,125	2,063
600	-	-	3,750	2,475
700	-	-	4,375	2,888
800	-	-	5,000	3,300
840	-	-	6,562	4,331
960	-	-	7,500	4,950

① Extended range minimum can be 75% of standard minimum.

② Extended range minimum can be 66% of standard minimum.

## Cooling Coil Operation

1. Airflow must be properly distributed across the coil face and should not vary by more than 20%.
2. Air velocities should be maintained between 200 and 550 feet per minute. Refer to Table 21.1.

	<b>SHOP DRAWING REVIEW</b> PER M/E SPECIFICATIONS SECTIONS	
	DATE <b>2026/04/29</b>	PROJECT No. <b>24333-08</b>
<input type="checkbox"/> NOT REVIEWED	<input checked="" type="checkbox"/> REVIEWED	
<input type="checkbox"/> RESUBMIT	<input type="checkbox"/> REVIEWED AS MODIFIED	
<input type="checkbox"/> NOT SPECIFIED BY MCW, REVIEWED FOR MEP ONLY		
ELECTRICAL REVIEWER: <b>R.A.</b>	MECHANICAL REVIEWER: <b>TT</b>	

# COMPONENT/OPTION LOCATION

For location of standard and optional factory installed components, refer to Figure 29.1 and the descriptions on the following pages.

**Figure 29.1 - Factory Mounted Option Locations**

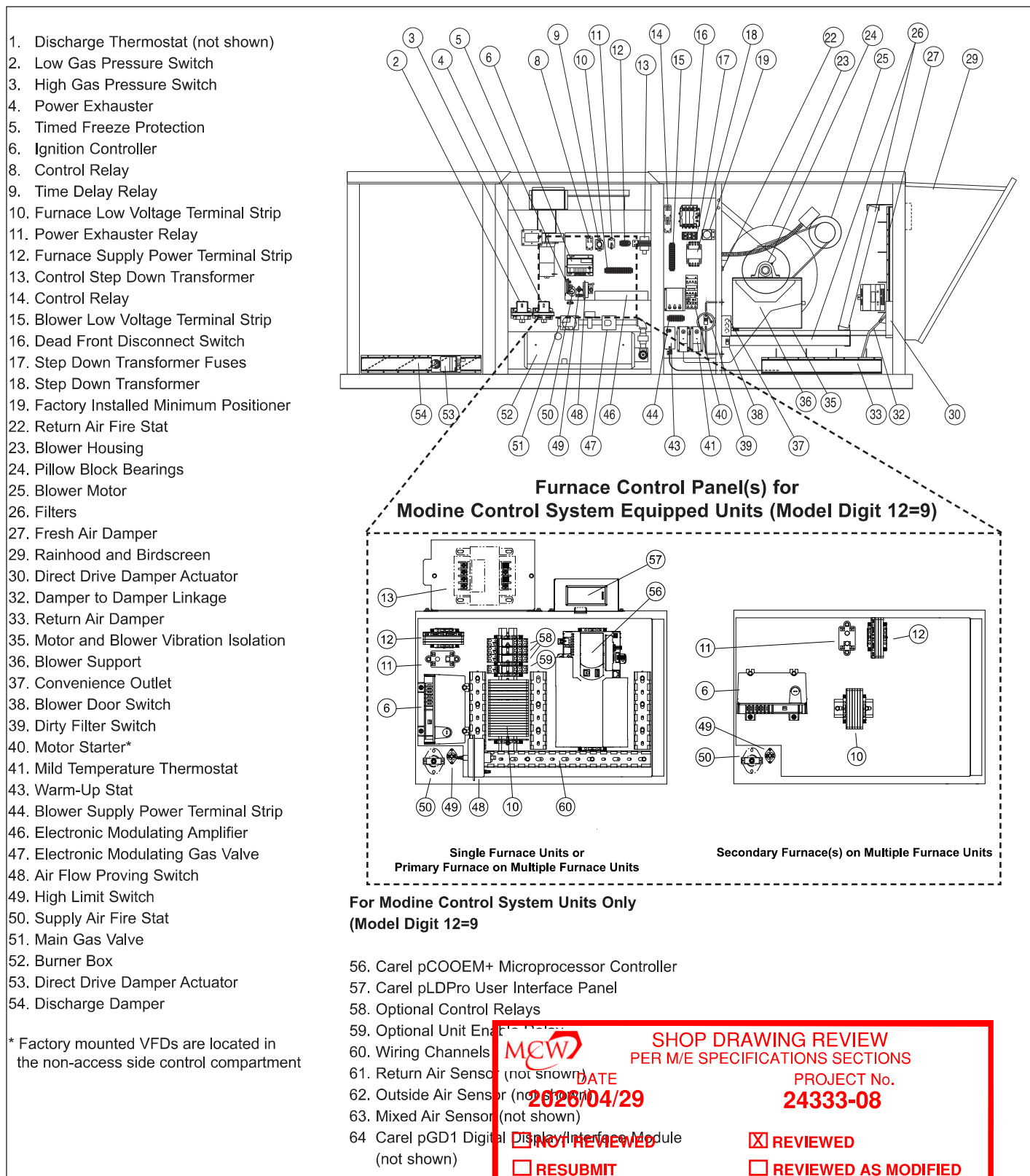

1. Discharge Thermostat (not shown)
2. Low Gas Pressure Switch
3. High Gas Pressure Switch
4. Power Exhauster
5. Timed Freeze Protection
6. Ignition Controller
8. Control Relay
9. Time Delay Relay
10. Furnace Low Voltage Terminal Strip
11. Power Exhauster Relay
12. Furnace Supply Power Terminal Strip
13. Control Step Down Transformer
14. Control Relay
15. Blower Low Voltage Terminal Strip
16. Dead Front Disconnect Switch
17. Step Down Transformer Fuses
18. Step Down Transformer
19. Factory Installed Minimum Positioner
22. Return Air Fire Stat
23. Blower Housing
24. Pillow Block Bearings
25. Blower Motor
26. Filters
27. Fresh Air Damper
29. Rainhood and Birdscreen
30. Direct Drive Damper Actuator
32. Damper to Damper Linkage
33. Return Air Damper
35. Motor and Blower Vibration Isolation
36. Blower Support
37. Convenience Outlet
38. Blower Door Switch
39. Dirty Filter Switch
40. Motor Starter\*
41. Mild Temperature Thermostat
43. Warm-Up Stat
44. Blower Supply Power Terminal Strip
46. Electronic Modulating Amplifier
47. Electronic Modulating Gas Valve
48. Air Flow Proving Switch
49. High Limit Switch
50. Supply Air Fire Stat
51. Main Gas Valve
52. Burner Box
53. Direct Drive Damper Actuator
54. Discharge Damper

**For Modine Control System Units Only  
(Model Digit 12=9)**

56. Carel pCOEM+ Microprocessor Controller
57. Carel pLDPro User Interface Panel
58. Optional Control Relays
59. Optional Unit End...
60. Wiring Channels
61. Return Air Sensor (not shown)
62. Outside Air Sensor (not shown)
63. Mixed Air Sensor (not shown)
64. Carel pGD1 Digital Display Interface Module (not shown)

**SHOP DRAWING REVIEW**  
PER M/E SPECIFICATIONS SECTIONS

DATE: **2026/04/29**

PROJECT No.: **24333-08**

NOT REVIEWED       REVIEWED  
 RESUBMIT             REVIEWED AS MODIFIED  
 NOT SPECIFIED BY MCW, REVIEWED FOR MEP ONLY

**ELECTRICAL REVIEWER:** R.A.      **MECHANICAL REVIEWER:** TT



# COMPONENT DESCRIPTIONS

## (6) Ignition Controller – (STD)

The ignition controller is factory installed in the duct furnace electrical junction box with the spark ignitor and sensor located on the burner. For both natural and propane gas units, the ignition controller is 100% shut-off with continuous retry. On a call for heat, the system will attempt to light the pilot for 70 seconds. If the pilot is not sensed for any reason, the ignition control will wait for approximately six minutes with the combination gas control closed and no spark. After six minutes, the cycle will begin again. After three cycles, some ignition controllers lockout for approximately one hour before the cycle begins again. This will continue indefinitely until the pilot flame is sensed or power is interrupted to the system.

## (8) Control Relay – (OPT)

The control relay(s) are factory installed in the duct furnace electrical junction box. The relay has a 24V coil with double-pole, double throw (DPDT) contacts. Refer to the unit wiring diagram for the switching function of the relay. The two normally open and two normally closed contacts are rated for a maximum of 30 amps @ 115V/1Ph.

## (9) Time Delay Relay – (STD)

The time delay relay is factory installed in the duct furnace electrical junction box. The time delay relay allows the gas controls to operate for approximately 30 seconds before the blower starts. This allows the heat exchanger a warm up period so that the initial delivered air is not cold. The time delay relay also keeps the motor running for approximately 30 seconds after the call for heat has been satisfied to remove the residual heat from the heat exchanger. For single phase units below 1-1/2 Hp, the time delay relay controls the motor directly. For single phase units 1-1/2 Hp and greater and all three phase units, the time delay relay controls the motor starter.

## (10) Furnace Low Voltage Terminal Strip – (STD)

The terminal strip is labeled to match the electrical wiring diagram provided with the unit. All field wiring connections should be made to the top side of the terminals to prevent miswiring by modifying the factory wiring which is made to the bottom of the terminal strip.

## (11) Power Exhaust Relay – (STD)

The control relay is factory installed in the duct furnace electrical junction box. On a call for heat, the relay coil is energized resulting in the contacts energizing the power exhauster motor.

## (12) Furnace Supply Power Terminal Strip – (STD)

The terminal strip is labeled to match the electrical wiring diagram provided with the unit. All field wiring connections should be made to the bottom side of the terminals to prevent miswiring by modifying the factory wiring which is made to the top of the terminal strip.

## (13) Step Down Transformer – (STD)

The control step down transformer is located in the duct furnace electrical junction box. The transformer steps down the supply power (115V, 208V, 230V, 460V, 575V) to 24V for the gas controls, damper actuator, relays, etc. Refer to Model Digit 15 of the unit nameplate nomenclature to determine the (A) capacity of the transformer.

## (14) Control Relay – (OPT)

The control relay is factory installed in the blower electrical section. See description of Option 8 for additional details.

## (15) Blower Low Voltage Terminal Strip – (STD)

The terminal strip is labeled to match the electrical wiring diagram provided with the unit. All field wiring connections should be made to the right side of the terminals to prevent miswiring by modifying the factory wiring which is made to the left side of the terminal strip.

## (16) Dead Front Disconnect Switch – (OPT)

**⚠ WARNING**

Disconnect power supply before making wiring connections or working on this equipment. Follow all applicable safety procedures to prevent accidental power up. Failure to do so can result in injury or death from electrical shock or moving parts and may cause equipment damage.

**⚠ AVERTISSEMENT**

Débranchez l'alimentation électrique avant d'effectuer des connexions ou de travailler sur l'appareil. Respectez toutes les procédures de sécurité qui s'appliquent pour éviter toute mise en marche accidentelle. Le non-respect de cette directive peut entraîner des blessures ou la mort causées par un choc électrique ou des pièces mobiles, en plus d'endommager l'appareil.

The dead front disconnect switch is factory installed in the blower electrical section. The disconnect switch is designed so that it must be turned "OFF" before entry to the electrical control cabinet can be obtained (see Figure 31.1). When in the "OFF" position, power is disconnected to all unit wiring electrically following the switch (See Warning). For servicing the unit, the disconnect switch can be manually overridden by using a wrench and turning the disconnect switch shaft 90° clockwise.

**Figure 31.1 - Dead Front Disconnect Switch Assembly**

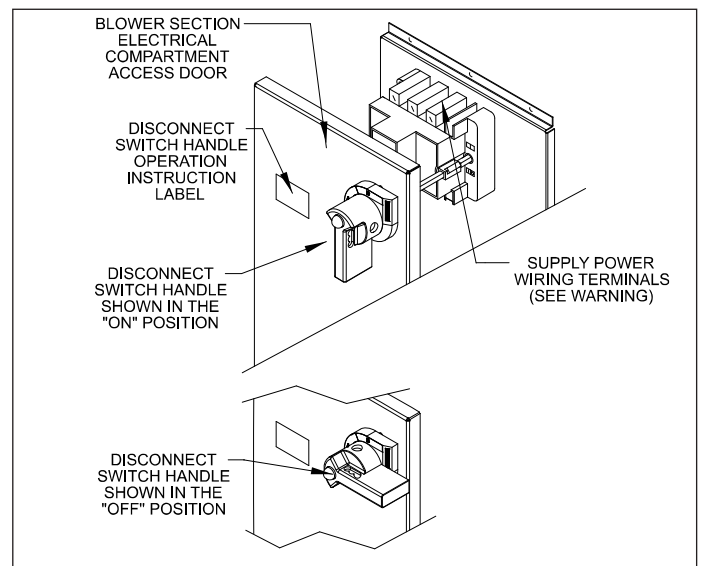

## (17) Step Down Transformer Fuses – (OPT)

The transformer fuses are factory installed in the blower electrical section. The fuses are included to protect the transformer.

**SHOP DRAWING REVIEW**

**DATE: 2026/04/29**

**BY: R.A.**

**24333-08**

**NOT REVIEWED**

**REVIEWED**

**NOT SPECIFIED BY MCW, REVIEWED FOR MEP ONLY**

**ELECTRICAL REVIEWER: MECHANICAL REVIEWER:**

**R.A.**

# COMPONENT DESCRIPTIONS

## (18) Step Down Transformer – (OPT)

The step down transformer is factory installed in the blower electrical section. The transformer is required as follows:

### Without Evap Cooler (Model Digit 22=0)

- Supply voltage of 460V/3Ph or 575V/3Ph (Model Digit 14=F or G). The transformer reduces the voltage to 115V for the power exhauster(s).

### With Evap Cooler (Model Digit 22=D)

- Supply voltage of 208V/1Ph or 208V/3Ph (Model Digit 14=B or D). The transformer reduces the voltage to 115V for the evaporative cooler. The power exhauster(s) will be 208V.
- Supply voltage of 460V/3Ph or 575V/3Ph (Model Digit 14=F or G). The transformer reduces the voltage to 115V for the power exhauster(s) and evaporative cooler.

For all other configurations, the transformer is not required.

## (19) Minimum Positioner – (OPT) (All Except Model Digit 12=9)

The factory installed minimum positioner is installed in the blower electrical section and is used with a modulating damper actuator to set the minimum percentage of outside air. The minimum positioner dial is manually set between 0 to 100% resulting in a 2 to 10 VDC signal being sent to the damper actuator.

For units with the Modine Control System option (Model Digit 12=9), this feature is available as a damper control when configured properly and does not require a separate additional positioner. Refer to the latest revision of the Modine Control System Manual, literature 74-510 for additional information.

Figure 32.1 - Minimum Positioner



## (22) Return Air Fire Stat – (OPT)

The return air fire stat is factory installed in the blower electrical section with the sensor in the return air stream. In case of elevated temperatures at the sensor, the manual reset switch shuts down the entire unit. If the limit temperature is exceeded, a service person must inspect the unit for the cause of the high temperature, take corrective action, and then reset the switch.

## (23) Blower Housing – (STD)

The blower section contains a double width, double inlet (DWDI) blower wheel. Both sides of the blower must be free from obstructions for proper operation. For Right Hand units (Model Digit 9 = R), during operation the blower wheel should rotate in the clockwise direction when viewed from the service side of the unit. For Left Hand units (Model Digit 9 = L), the blower wheel should rotate in the counterclockwise direction when viewed from the service side of the unit. If necessary, interchange supply power wiring to reverse blower rotation.

## (24) Pillow Block Bearings – (OPT)

The blower can be provided with either spider or pillow block

bearings. Spider bearings are permanently lubricated and do not require lubrication. Pillow block bearings are shipped non-greased from the factory and require lubrication before start-up. For lubrication recommendations, see Lubrication Recommendations.

## (25) Blower Motor – (STD)

The blower motor can be provided in a variety of supply voltages, frame types, and motor horsepower. Refer to the model nomenclature to determine the type of motor provided. The blower motor is supplied with an adjustable sheave that can be used to increase/decrease the blower RPM. For instructions on changing the blower RPM, refer to Blower Adjustments.

## (26) Filters – (OPT)

When filters are supplied with the unit, a rack and the filters are factory installed in the blower section. The unit can be supplied with 2" permanent filters, 2" pleated throwaway filters in MERV 8 or 13 ratings. For filter replacement, refer to Maintenance.

## (27) Fresh Air Damper – (OPT)

When a fresh air damper is supplied with the unit, the damper is used as an outside air shut-off damper. The damper is ultra low leak, Class II leakage resistance (less than 10 CFM/ft<sup>2</sup> at 1" W.C.) dampers with self-compensating stainless steel side seals and santoprene and galvanized steel blade seals.

## (29) Rainhood and Birdscreen – (OPT)

The rainhood and birdscreen is shipped loose for field installation at the back of the blower section. For installation instructions, refer to Literature 5-589, latest revision.

## (30) Direct Drive Damper Actuator – (OPT)

The direct drive damper actuator is factory installed on the side of the fresh air damper. The return air damper, if provided, is controlled by the damper linkage between the two dampers. All damper actuators are low voltage (24V). For Right Hand units (Model Digit 9 = R), during operation the actuator should rotate in the counterclockwise direction when viewed from the service side of the unit. For Left Hand units (Model Digit 9 = L), the actuator should rotate in the clockwise direction when viewed from the service side of the unit. Two different types of dampers actuators can be provided: Two Position and Modulating.

- Two-Position Damper Actuator:** A two-position actuator is provided with Air Control options (Model Digits 20-21=DA and EA). The actuator provides open/closed operation of the fresh air damper. When the actuator is energized, the fresh air damper is opened to 100% outside air in 75 seconds (for outside air percentages lower than 100%, refer to the following section, "Setting the Damper Limiter"). Actuators are spring return, so when the damper is de-energized, the fresh air damper will spring closed. Actuator include auxiliary switches (one normally open and one normally closed) that reverse when the damper actuator is at 85° rotation (adjustable). Setting the Damper Limiter: The two-position damper limiter can be factory set to prevent the outside air damper from opening to 100%. Field adjustment of the two-position damper limiter is accomplished by the following:

SHOP DRAWING REVIEW

DATE: 2026/04/29 TIME: 2:45PM '08

<input type="checkbox"/> NOT REVIEWED	<input checked="" type="checkbox"/> REVIEWED
<input type="checkbox"/> RESUBMIT (continued next page)	<input type="checkbox"/> REVIEWED AS MODIFIED
<input type="checkbox"/> NOT SPECIFIED BY MCW, REVIEWED FOR MEP ONLY	
<b>ELECTRICAL REVIEWER:</b> R.A.	<b>MECHANICAL REVIEWER:</b> TT

# COMPONENT DESCRIPTIONS

1. Determine the maximum outside air % required.
2. Locate the angle of rotation limiter on the actuator so that its edge lines up with the degree graduation on the actuator face corresponding to the required rotation. (See figure below which is shown at 50% rotation limit.)
3. Position the limiter to the desired position, making sure the locating "teeth" on the limiter are engaged into the locating holes on the actuator.
4. Fasten the limiter to the actuator using the screw provided.
5. Test the damper rotation either manually with the manual crank or apply power. Re-adjust if necessary.
6. If the damper end switch is being used in the control circuit and needs to be adjusted for the new limit position, refer to the next section, "Adjusting the Damper End Switch".

**Figure 33.1 - Two-Position Damper Actuator Limiter**

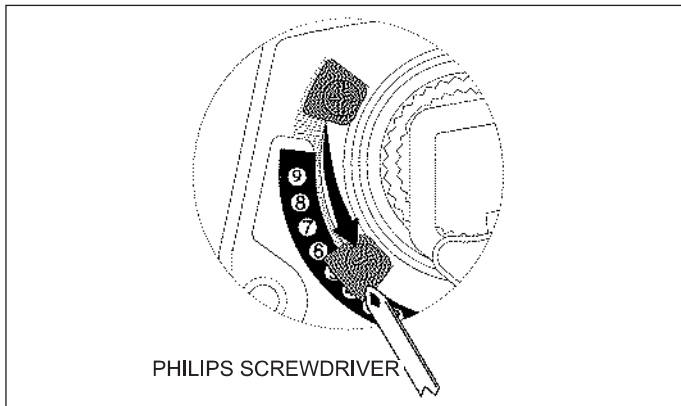

**Adjusting the Damper End Switch:** If the damper limiter was adjusted in the previous section, it may be required to adjust the Damper End Switch as follows:

1. The actuator must be in its fail-safe position.
2. Insert the crank handle into the Torx shaped hole in the center of the adjustable switch pointer as shown below.
3. Gently rotate the crank until the switch pointer is at the desired switch point in degrees as shown.

**Figure 33.2 - Adjusting the Damper End Switch**

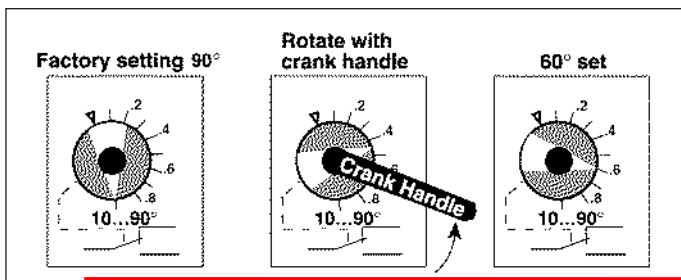

- **Modulating Damper Actuator:** A modulating actuator is provided with Air Control options (Model Digits 20-21=GA, GC, or GE). The actuator provides incremental operation of the fresh air damper (the return air damper is controlled by the fresh air damper position). Full 90° rotation of the actuator requires 150 seconds. Actuators operate using a 0-10 Vdc input signal from a damper controller. Actuators are spring return, so when the damper is de-energized, the fresh air damper will spring closed. For units with the Modine Control System option (Model Digit 12=9), when the damper control is modulating, Model Digits 20-21 will always be GA and the control will be integral to the Modine Control System control logic. Refer to the latest revision of the Modine Control System Manual, literature 74-510 for additional information.

### (32) Damper to Damper Linkage – (OPT)

Units with fresh and return air dampers include a damper actuator that controls the fresh air damper. The return air damper position is controlled by the fresh air damper through the connecting rod. For adjustment, refer to Damper Linkage Adjustment.

### (33) Return Air Damper – (OPT)

When a return air damper is supplied with the unit, the damper is factory installed in the blower section. The return air damper is used as an air balancing damper so low leak, Class III leakage resistance (less than 40 CFM/ft<sup>2</sup> at 1" W.C.) dampers with self-compensating stainless steel side seals and santoprene blade seals are used.

### (35) Motor and Blower Vibration Isolation – (STD)

The motor vibration isolation is factory installed below the blower support bracket. The four (4) neoprene vibration mount grommets provide isolation of the blower housing and motor from the blower support channels. The blower duct connection is not rigidly mechanically fastened and the 1/4" thick gasketing around the duct transition provides vibration isolation.

**Figure 33.3 - Blower/Motor Vibration Isolation**

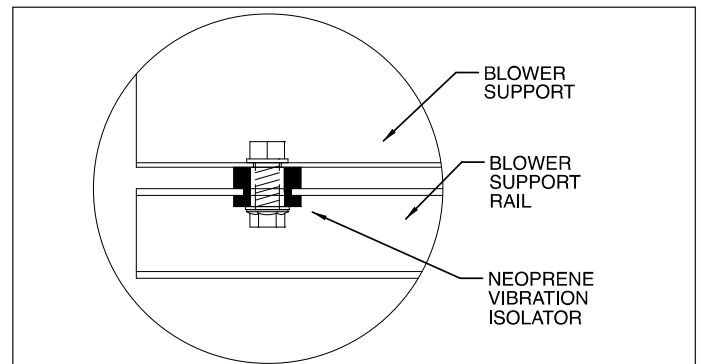

### (36) Blower Support – (STD)

The blower supports are factory installed in the blower section. The blower supports are used to rigidly support the weight of the blower and motor during operation and shipping.



SHOP DRAWING REVIEW  
PER M/E SPECIFICATIONS SECTIONS

DATE  
**2026/04/29**

PROJECT No.  
**24333-08**

NOT REVIEWED

REVIEWED

RESUBMIT

REVIEWED AS MODIFIED

NOT SPECIFIED BY MCW, REVIEWED FOR MEP ONLY

ELECTRICAL REVIEWER:  
**R.A.**

MECHANICAL REVIEWER:  
**TT**

# COMPONENT DESCRIPTIONS

## (37) Convenience Outlet – (OPT)

### ⚠ WARNING

Disconnect power supply before making wiring connections or working on this equipment. Follow all applicable safety procedures to prevent accidental power up. Failure to do so can result in injury or death from electrical shock or moving parts and may cause equipment damage.

### ⚠ AVERTISSEMENT

Débranchez l'alimentation électrique avant d'effectuer des connexions ou de travailler sur l'appareil. Respectez toutes les procédures de sécurité qui s'appliquent pour éviter toute mise en marche accidentelle. Le non-respect de cette directive peut entraîner des blessures ou la mort causées par un choc électrique ou des pièces mobiles, en plus d'endommager l'appareil.

The convenience outlet is factory installed in the blower section for providing power for 115V service equipment (trouble light, power tools, etc.). The 115V ground fault circuit interrupter (GFCI) is rated for 15 amps and includes test and reset switches. A separate field supplied 115V/1Ph power supply must be routed through the electrical section wall into the back of the convenience outlet junction box.

## (38) Blower Door Switch – (OPT)

The blower door switch is installed inside the blower section door on the access side of the unit. If the door is removed, the switch interrupts power to the low voltage circuit. For single phase units 1-1/2 Hp and less, the switch de-energizes a relay that controls blower motor operation. For three phase units and single phase units 1-1/2 Hp and greater, the switch de-energizes the motor starter that controls blower motor operation. For servicing, the switch has an override position that can be manually pulled out to override the switch as shown below. For units with Modine Control System option (Model Digit 12=9), the switch is wired to a digital input on the unit controller.

**Figure 34.1 - Blower Door Switch with Manual Override**

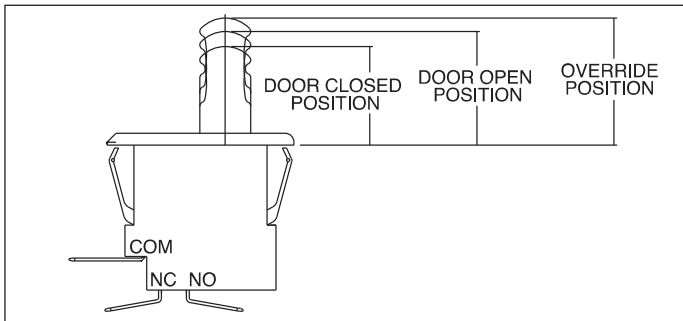

## (39) Dirty Filter Switch – (OPT)

The dirty filter pressure switch is factory installed in the blower electrical section. The switch monitors the pressure differential between the two sides of the filters. When the filters become dirty, the differential pressure increases and trips the pressure switch which energizes a light on the remote monitoring panel (for units with Modine Control System option (Model Digit 12=9), the switch is wired to a digital input on the unit controller). The switch must be field set with ductwork installed and the blower in operation.

## Setting the Dirty Filter Switch

The range of the switch is adjustable between 0.17" to 5.0" W.C.

1. Ensure that the unit filters are clean or replace if necessary.
2. Connect leads of a continuity tester to the NO and C terminals of the pressure switch. See the figure below.
3. Turn the set screw of the pressure switch clockwise until it stops. This will set the pressure at 5.0" W.C. and the continuity tester should be sensing an open circuit.
4. Begin turning the screw counterclockwise until the continuity tester senses a closed circuit. This determines the base pressure of the system.
5. Turn the screw clockwise until the continuity tester senses an open circuit and then one additional full turn (This is approximately 0.25" W.C.) This will allow for the increase in static pressure due to dirty filters.

**Figure 34.2 - Dirty Filter Pressure and/or Air Flow Proving Switch**

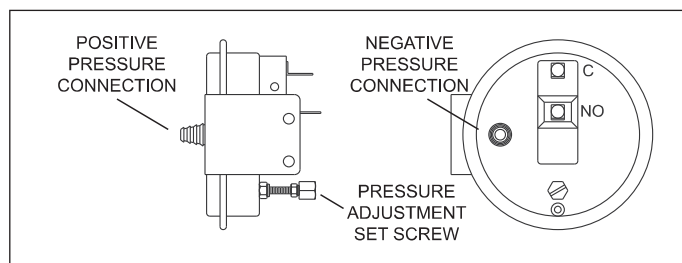

## (40) Motor Starter – (OPT)

The motor starter is factory installed in the blower electrical section. A motor starter is required for:

- All three phase motors
- Single phase motors 1-1/2 Hp and greater

If the factory installed motor starter option was not ordered with a unit that requires it, a motor starter must be field supplied and installed. Alternatively for three phase motors, see also the Variable Frequency Drive option below.

The overload module of the motor starter is designed to protect the motor from exceeding the nameplate amps. If the motor exceeds the amp draw on the current set point dial, the trip condition is indicated by a red color in the trip indicator window. The current set point dial is factory set to the motor full load amps listed on the motor nameplate.

The motor starter can be placed in the automatic or manual reset positions. Automatic reset is accomplished by depressing the "RESET" button and turning the button 1/4 turn. When in the automatic reset position, if the overload module trips, the module will reset itself once the overload relay has cooled. In the manual reset position, if the overload module trips, the "RESET" button must be depressed before the blower can

**SHOP DRAWING REVIEW**

factor module includes one (1) normally open auxiliary contact. The contact rating is 10 amps.

DATE: **2026/04/29** PROJECT No. **24333-08**

(continued next page)

<input type="checkbox"/> NOT REVIEWED	<input checked="" type="checkbox"/> REVIEWED
<input type="checkbox"/> RESUBMIT	<input type="checkbox"/> REVIEWED AS MODIFIED
<input type="checkbox"/> NOT SPECIFIED BY MCW, REVIEWED FOR MEP ONLY	
ELECTRICAL REVIEWER: <u>R.A.</u>	MECHANICAL REVIEWER: <u>TT</u>

# COMPONENT DESCRIPTIONS

Figure 35.1 - Motor Starter

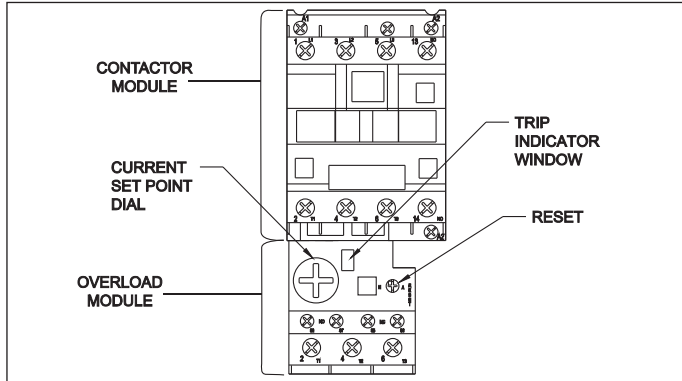

### (40) Variable Frequency Drive – (OPT)

The VFD controller adjusts the motor rpm to vary the unit air flow. The minimum air flow may be varied between 30 and 100% of the full speed air flow depending on the controls selection of the unit (refer to the section "Variable Air Volume Applications" on page 28 for additional information). The control changeover options include two speeds, and building management control. For units with the Modine Control System option (Model Digit 12=9), additional control options may be available. Refer to the latest revision of the Modine Control System Manual, literature 74-510 for additional information.

### (41) Mild Temperature Stat – (OPT) (All Except Digit 12=9)

The mild temperature thermostat is factory installed in the blower electrical section. The mild temperature thermostat is designed to lockout the burner during mild weather conditions which prevents the burner from cycling. The thermostat must be field set to the desired mild temperature condition (refer to the latest revision of Modine Literature 75-540).

For units with the Modine Control System option (Model Digit 12=9), this feature is integral to the control logic and utilizes existing sensors included with that option. Refer to the latest revision of the Modine Control System Manual, literature 74-510 for additional information.

### (43) Warm-Up Stat – (OPT) (All Except Model Digit 12=9)

A warm-up stat can be provided with Air Control options (Model Digits 20-21=EA, GC, or GE) and factory installed in the blower electrical section with the sensor in the return air stream. The warm-up thermostat monitors the return air temperature upon changing to the occupied mode and prevents the fresh air dampers from opening until the temperature of the return air has reached the desired set point (typically 65°F or 5°F below the room temperature).

### (44) Blower Supply Power Terminal Strip – (STD)

The terminal strip is labeled to match the electrical wiring diagram provided with the unit. All field wiring connections should be made to the bottom side of the terminals to prevent miswiring by modifying the factory wiring which is made to the top of the terminal strip.

### (46) Electronic Modulation Amplifier – (OPT)

An electronic modulation amplifier is provided factory installed in the duct furnace electrical junction box when the unit is equipped with Electronic Modulating Gas Controls (Model Digit 12=4). The amplifier processes the thermostat temperature and set point signals to modulate the firing rate between 40% to 100% full fire. For additional information, refer to Control Operating Sequence.

### (47) Electronic Modulating Gas Valve – (OPT)

An electronic modulating gas valve is provided factory installed in the duct furnace gas train when the unit is equipped with Electronic Modulating Gas Controls (Model Digit 12=4, 7, or 9). The gas valve modulates the firing rate between 40% to 100% full fire based on the input signal from the Electronic Modulation Amplifier (Model Digit 12=4), Signal Conditioner (Model Digit 12=7), or Modine Control System controller (Model Digit 12=9). For additional information, refer to the Furnace Control Operating Sequence section in this manual.

### (48) Air Flow Proving Switch – (OPT)

The air flow proving switch is factory installed in the duct furnace electrical junction box. The air flow proving switch monitors the pressure differential between the duct furnace and the atmosphere. The purpose of the air flow proving switch is to cut power to the gas controls if a positive pressure is not measured by the switch. This could be caused by a lack of air movement through the heat exchanger.

**Note:** The air flow proving switch will prevent any heat exchanger warm-up because the gas controls can not be energized until air flow is proven.

### Setting the Air Flow Proving Switch

The range of the switch is adjustable between 0.17" to 5.0" W.C.

1. Set the thermostat or controller so that there is a call for heat. For units with the Modine Control System option (Model Digit 12=9), refer to the latest revision of the Modine Control System Manual, literature 74-510 for additional information.
2. Turn the set screw of the pressure switch clockwise until it stops. This will set the pressure at 5.0" W.C.
3. Turn the screw counter-clockwise until the gas controls light and then one additional full turn. This will allow for dirty filters or other slight system static pressure increases.

### (49) High Limit Switch

The high limit switch is factory installed in the duct furnace electrical junction box. If the limit temperature is exceeded, the gas controls are de-energized.

- Automatic – (STD): The automatic reset high limit will reset when the switch is cooled.

### (50) Supply Air Fire Stat – (OPT)

The supply air fire stat is factory installed in the duct furnace electrical junction box with the sensor in the discharge air stream. In case of elevated temperatures in the supply air stream, the manual reset switch shuts down the entire unit. If the limit temperature is exceeded, a service person must inspect the unit for the cause of the high discharge temperature, take corrective action, and then reset the switch.

### (51) Main Gas Valve – (STD)

The main gas valve is factory installed in the duct furnace gas train. The main gas valve controls the gas flow to the burner, gas control valve, and annual shutoff functions. For additional information, see the supplier literature included with the unit.

SHOP DRAWING REVIEW

PER ME SPECIFICATIONS SECTIONS

PROJECT No. 24333-08

DATE 2026/04/29

<input type="checkbox"/> NOT REVIEWED	<input checked="" type="checkbox"/> REVIEWED
<input type="checkbox"/> RESUBMIT	<input type="checkbox"/> REVIEWED AS MODIFIED
<input type="checkbox"/> NOT SPECIFIED BY MCW, REVIEWED FOR MEP ONLY	
ELECTRICAL REVIEWER: R.A.	MECHANICAL REVIEWER: TT

## COMPONENT DESCRIPTIONS

### (52) Burner Box – (STD)

The burner box is located in the duct furnace section and contains the burner and pilot assembly. The burner box includes an access panel for removal of the burner for inspection and servicing.

### (53) Direct Drive Discharge Damper Actuator – (OPT)

The direct drive damper actuator is factory installed on the side of the discharge damper (available as an option on units with Model Digit 2=D or P). All discharge damper actuators are low voltage (24V), two-position, spring return type. For Right Hand units (Model Digit 9 = R), during operation the actuator should rotate in the counterclockwise direction when viewed from the service side of the unit. For Left Hand units (Model Digit 9 = L), the actuator should rotate in the clockwise direction when viewed from the service side of the unit.

The actuator provides open/closed operation of the discharge air damper. When the actuator is energized, the damper is opened to 100% outside air in 75 seconds. Actuators are spring return, so when the damper is de-energized, the air damper will spring closed. Actuator include auxiliary switches (one normally open and one normally closed) that reverse when the damper actuator is at 85° rotation (adjustable). When the damper is closed, the unit is not operating.

### (54) Discharge Damper – (OPT)

When a discharge air damper is supplied with the unit, the damper is factory installed in the downturn plenum section. The discharge air damper is used as an outside air shut-off damper so ultra low leak, Class II leakage (less than 10 CFM/ft<sup>2</sup> at 1" W.C.) dampers with self-compensating stainless steel side seals and santoprene and galvanized steel blade seals are used.

### For Modine Control System Units Only (Model Digit 12=9)

The following items may be included with units configured with the Modine Control System option:

### (56) Carel pCOEM+ Microprocessor Controller

The Modine Controls System utilizes a Carel pCOEM+ programmable microprocessor controller that is factory installed in the duct furnace electrical section.

### (57) Carel pLDPro User Interface Panel

The interface allows a user to access the Carel controller for setpoint changes and to view the operational status of the equipment. The interface features an LED backlit graphic display and buttons for excellent visibility.

### (58) Control Relays - (OPT)

The control relay(s) are factory installed in the duct furnace electrical junction box. The relay has a 24V coil with double-pole, double throw (DPDT) contacts. Refer to the unit wiring diagram for the switching function of the relay. The two normally open and two normally closed contacts are rated for a maximum of 8A @ 230V/1Ph.

### (59) Unit Enable Relay - (OPT)

The control relay is factory installed in the duct furnace electrical junction box and is used to enable the unit based on contact closure from a customer enable circuit. The closing of that contact will power a 24V relay from the unit mounted controller and enable the unit in On or Occupied mode. The relay provides electrical isolation to the controller for protection.

### (60) Wiring Channels with Cover - (STD)

The wiring channels organize and separate high voltage and low voltage wiring.

### (61) Return Air Sensor (not shown) - (OPT)

This sensor is required on all units that have a mixture of outside and return air. The sensor is field mounted in the return air ductwork. It may be dry bulb only or enthalpy (temperature and humidity).

### (62) Outside Air Sensor (not shown) - (OPT)

This sensor is required on all units except 100% return air units and is field installed. Depending on the unit configuration, the sensor may be duct mounted or remote mounted. It may be dry bulb only or enthalpy (temperature and humidity).

### (63) Mixed Air Sensor (not shown) - (OPT)

This sensor is required on all units that have a mixture of outside and return air and is factory mounted in the blower cabinet. The sensor is dry bulb temperature only.

### (64) Carel pGD1 Digital Display/Interface Module (not shown) - (OPT)

The interface allows a user to access the Carel controller remotely for setpoint changes and to view the operational status of the equipment. The interface features an LED backlit graphic display and buttons for excellent visibility. Also included is a buzzer to indicate alarm conditions. The interface can be used as a handheld device or can be wall mounted. Maintenance personnel may wish to have the pGD1 mounted in an equipment control room.

Refer to the latest revision of the Modine Control System Manual, literature 74-510 for additional information

	<b>SHOP DRAWING REVIEW</b> PER M/E SPECIFICATIONS SECTIONS	
	DATE <b>2026/04/29</b>	PROJECT No. <b>24333-08</b>
<input type="checkbox"/> NOT REVIEWED	<input checked="" type="checkbox"/> REVIEWED	
<input type="checkbox"/> RESUBMIT	<input type="checkbox"/> REVIEWED AS MODIFIED	
<input type="checkbox"/> NOT SPECIFIED BY MCW, REVIEWED FOR MEP ONLY		
ELECTRICAL REVIEWER: <b>R.A.</b>	MECHANICAL REVIEWER: <b>TT</b>	



# GENERAL PERFORMANCE DATA

**Table 38.1 - Air Temperature Rise** ①②③

Model Size	Btu/Hr Input ①	Btu/Hr Output ①	Air Temperature Rise Through Unit (°F)									
			20	40	50	60	70	80	90	100	110	120
100	100,000	81,000	3,750	1,875	1,500	1,250	1,071	938	833	750	-	-
125	125,000	101,250	4,688	2,344	1,875	1,563	1,339	1,172	1,042	937	-	-
150	150,000	121,500	5,500	2,813	2,250	1,875	1,607	1,406	1,250	1,125	-	-
175	175,000	141,750	5,500	3,281	2,625	2,188	1,875	1,641	1,458	1,312	-	-
200	200,000	162,000	6,500	3,750	3,000	2,500	2,143	1,875	1,667	1,500	-	-
225	225,000	182,250	6,500	4,219	3,375	2,813	2,411	2,109	1,875	1,687	-	-
250	250,000	202,500	9,375	4,688	3,750	3,125	2,679	2,344	2,083	1,875	-	-
300	300,000	243,000	11,250	5,625	4,500	3,750	3,214	2,813	2,500	2,250	-	-
350	350,000	283,500	12,000	6,563	5,250	4,375	3,750	3,281	2,917	2,625	-	-
400	400,000	324,000	12,000	7,500	6,000	5,000	4,286	3,750	3,333	3,000	-	-
500	500,000	405,000	-	9,375	7,500	6,250	5,357	4,688	4,167	3,750	3,409	3,125
600	600,000	486,000	-	11,250	9,000	7,500	6,429	5,625	5,000	4,500	4,091	3,750
700	700,000	567,000	-	13,000	10,500	8,750	7,500	6,563	5,833	5,250	4,773	4,375
800	800,000	648,000	-	14,500	12,000	10,000	8,571	7,500	6,667	6,000	5,455	5,000
840	1,050,000	850,500	-	-	-	13,000	11,250	9,844	8,750	7,875	7,159	6,562
960	1,200,000	972,000	-	-	-	14,500	12,857	11,250	10,000	9,000	8,182	7,500

① Ratings are shown for elevations up to 2000 feet. For higher elevations, refer to section "Considerations for Elevation" on page 17.

② Minimum Air Temperature Rise, Maximum Air Temperature Rise, and Maximum Discharge Air Temperature are as follows:

-For Model Sizes 100-400, Min Air Temp Rise is 20°F, Max Air Temp Rise is 100°F, and Max Discharge Air Temp is 150°F.

-For Model Sizes 500-800, Min Air Temp Rise is 40°F, Max Air Temp Rise is 120°F, and Max Discharge Air Temp is 150°F.

-For Model Sizes 840-960, Min Air Temp Rise is 60°F, Max Air Temp Rise is 120°F, and Max Discharge Air Temp is 150°F.

-Note that these are typical limits but may vary by Model Size. Refer to Table 37.1 for actual limits.

③ For Variable Air Movement Applications, see page 28.

## Air Temperature Limits

The maximum allowable discharge air temperature is 150°F. The maximum allowable air temperature rise per furnace for Low Air Temperature Rise Units is 60°F. All system units are designed for a maximum allowable total static pressure of 3.0" W.C.

		<b>SHOP DRAWING REVIEW</b>	
		PER M/E SPECIFICATIONS SECTIONS	
DATE		PROJECT No.	
<b>2026/04/29</b>		<b>24333-08</b>	
<input type="checkbox"/> NOT REVIEWED	<input checked="" type="checkbox"/> REVIEWED		
<input type="checkbox"/> RESUBMIT	<input type="checkbox"/> REVIEWED AS MODIFIED		
<input type="checkbox"/> NOT SPECIFIED BY MCW, REVIEWED FOR MEP ONLY			
ELECTRICAL REVIEWER:		MECHANICAL REVIEWER:	
<u>R.A.</u>		<u>TT</u>	

# OPTION & ACCESSORY PRESSURE DROP DATA

Table 39.1 - Option & Accessory Pressure Drop Tables (in "W.C.) ①

Unit Size	Digit 16	CFM	Filters			Evap Cooler, 12" Media		Other		
			2" Permanent	2" Farr Aeropleat	2" Farr 30/30	Without Pre-Filters	With Pre-Filters	Downturn Plenum	Rainhood and Birdscreen	Discharge Damper
100/125	C, D, E, F	741	0.02	0.02	0.02	0.02	0.08	0.00	0.03	0.01
		1,000	0.02	0.03	0.04	0.04	0.12	0.01	0.05	0.01
		1,500	0.04	0.05	0.07	0.08	0.23	0.02	0.07	0.02
		2,000	0.06	0.07	0.10	0.15	0.36	0.04	0.10	0.03
		2,500	0.08	0.10	0.14	0.23	0.53	0.07	0.13	0.04
		3,000	0.11	0.13	0.19	0.34	0.73	0.11	0.16	0.05
		3,500	0.13	0.16	0.24	0.46	0.97	0.15	0.19	0.07
		4,000	0.16	0.20	0.30	0.60	1.23	0.19	0.22	0.09
		4,500	0.20	0.25	0.37	4000 Max CFM for Evap		0.25	0.25	0.11
		4,630	0.21	0.26	0.39			0.26	0.26	0.11
150/175	C, D, E, F	1,111	0.02	0.03	0.04	0.03	0.09	0.02	0.02	0.01
		1,500	0.03	0.04	0.05	0.05	0.15	0.02	0.03	0.01
		2,000	0.04	0.06	0.08	0.09	0.24	0.04	0.05	0.02
		2,500	0.06	0.09	0.11	0.14	0.34	0.05	0.08	0.02
		3,000	0.08	0.11	0.15	0.20	0.46	0.07	0.10	0.04
		3,500	0.11	0.14	0.18	0.27	0.61	0.10	0.14	0.05
		4,000	0.13	0.18	0.23	0.35	0.77	0.13	0.18	0.06
		4,500	0.16	0.21	0.27	0.45	0.95	0.17	0.22	0.08
		5,000	0.19	0.25	0.32	0.55	1.15	0.21	0.27	0.10
		5,200	0.21	0.27	0.34	0.60	1.23	0.23	0.29	0.11
200/225	C, D, E, F, G, H	1,481	0.02	0.03	0.03	0.04	0.12	0.02	0.03	0.01
		2,000	0.02	0.04	0.04	0.07	0.19	0.03	0.05	0.01
		2,500	0.04	0.05	0.06	0.10	0.27	0.04	0.08	0.02
		3,000	0.05	0.07	0.08	0.15	0.36	0.06	0.10	0.04
		3,500	0.06	0.09	0.10	0.20	0.47	0.09	0.14	0.05
		4,000	0.08	0.11	0.12	0.27	0.60	0.11	0.18	0.06
		4,500	0.10	0.13	0.15	0.34	0.73	0.14	0.22	0.08
		5,000	0.11	0.16	0.18	0.42	0.89	0.18	0.27	0.10
		5,500	0.14	0.19	0.21	0.50	1.05	0.21	0.32	0.12
		6,000	0.16	0.22	0.25	0.60	1.23	0.26	0.38	0.14
250/300 500/600	E, F, G, H	1,852	0.02	0.05	0.05	0.05	0.15	0.02	0.07	0.02
		2,000	0.03	0.05	0.06	0.06	0.17	0.02	0.08	0.02
		2,500	0.04	0.07	0.09	0.09	0.24	0.03	0.09	0.03
		3,000	0.06	0.10	0.11	0.13	0.32	0.04	0.12	0.04
		3,500	0.08	0.12	0.15	0.17	0.41	0.06	0.14	0.06
		4,000	0.10	0.15	0.18	0.23	0.52	0.08	0.16	0.07
		4,500	0.13	0.18	0.22	0.29	0.64	0.10	0.19	0.09
		5,500	0.19	0.25	0.31	0.43	0.91	0.15	0.25	0.13
		6,500	0.26	0.34	0.42	0.60	1.23	0.21	0.31	0.18
		7,250	0.32	0.41	0.51	6500 Max CFM		0.27	0.37	0.23
350/400 700/800 840/960	E, F, G, H	1,925	0.01	0.03	0.03	0.02	0.08	0.02	0.07	0.02
		3,000	0.03	0.05	0.05	0.05	0.15	0.04	0.12	0.04
		4,000	0.05	0.08	0.09	0.09	0.23	0.08	0.16	0.07
		5,000	0.08	0.11	0.12	0.14	0.34	0.12	0.22	0.11
		6,000	0.11	0.15	0.16	0.20	0.46	0.18	0.28	0.16
		7,000	0.15	0.19	0.21	0.27	0.61	0.25	0.35	0.21
		8,000	0.20	0.24	0.27	0.35	0.77	0.33	0.42	0.28
		9,000	0.25	0.30	0.33	0.45	0.95	0.42	0.51	0.35
		10,400	0.33	0.38	0.42	0.60	1.23	0.57	0.64	0.47
		11,111	0.38	0.43	0.47	10400 Max CFM		0.66	0.71	0.53
350/400 700/800 840/960	I, J, K	2,593	0.02	0.04	0.04	0.05	0.16	0.02	0.03	0.01
		3,000	0.02	0.05	0.05	0.07	0.20	0.03	0.04	0.01
		3,500	0.03	0.06	0.06	0.10	0.25	0.04	0.05	0.01
		4,000	0.04	0.07	0.08	0.13	0.32	0.05	0.07	0.01
		4,500	0.05	0.09	0.10	0.16	0.39	0.06	0.09	0.02
		5,000	0.06	0.10	0.12	0.20	0.47	0.07	0.11	0.02
		5,500	0.07	0.12	0.14	0.24	0.55	0.09	0.14	0.03
		6,000	0.08	0.14	0.17	0.29	0.64	0.10	0.17	0.04
		6,500	0.10	0.16	0.19	0.34	0.74	0.12	0.20	0.04
		7,000	0.11	0.18	0.22	0.39	0.85	0.14	0.23	0.05
350/400 700/800 840/960	I, J, K	2,593	0.01	0.02	0.02	0.03	0.11	0.02	0.03	0.01
		3,000	0.02	0.02	0.03	0.04	0.14	0.03	0.04	0.01
		4,000	0.03	0.04	0.04	0.08	0.22	0.05	0.07	0.01
		5,000	0.04	0.06	0.06	0.12	0.31	0.07	0.11	0.02
		6,000	0.05	0.08	0.08	0.18	0.41	0.09	0.14	0.03
		7,000	0.07	0.10	0.10	0.24	0.52	0.12	0.18	0.04
		8,000	0.09	0.13	0.13	0.32	0.64	0.15	0.23	0.05
		9,000	0.12	0.15	0.16	0.40	0.75	0.19	0.30	0.08
		10,000	0.14	0.19	0.23	0.50	0.86	0.24	0.38	0.10
		11,050	0.17	0.22	0.23	0.61	1.24	0.30	0.48	0.14
350/400 700/800 840/960	I, J, K	12,000	0.20	0.27	0.27	11030 Max CFM		0.43	0.69	0.21
		12,500	0.22	0.30	0.31			0.47	0.75	0.23
		13,000	0.24	0.30	0.31			0.51	0.81	0.26

① Accessory / Option static pressure losses are approximate. Please consult the Accuspec selection software for static pressure losses at other than listed CFM.

SHOP DRAWING REVIEW  
PER M/E SPECIFICATIONS SECTIONS

DATE: 2026/04/29 PROJECT No. 24393-08

NOT REVIEWED       REVIEWED  
 RESUBMIT                       REVIEWED AS MODIFIED

ELECTRICAL REVIEWER: R.A.      MECHANICAL REVIEWER: TT

# BLOWER PERFORMANCE DATA

Table 40.1 - Unit Performance Tables ①②

Unit Size	Digit 16	Air Temp. Rise	CFM	Total Static Pressure, "W.C.																			
				0.25		0.50		0.75		1.00		1.25		1.50		2.00		2.50		3.00			
				BHP	RPM	BHP	RPM	BHP	RPM	BHP	RPM	BHP	RPM	BHP	RPM	BHP	RPM	BHP	RPM	BHP	RPM		
100/125 Start 125	C,D	100°F/-	741	-	-	0.15	808	0.23	962	0.30	1093	0.38	1212	0.47	1320	0.60	1514	0.86	1686	1.07	1840		
		80°F/100°F	926	0.13	670	0.21	846	0.29	993	0.38	1121	0.47	1236	0.56	1342	0.77	1532	0.99	1702	1.22	1856		
		62°F/77°F	1200	0.22	758	0.31	916	0.41	1052	0.52	1173	0.62	1282	0.74	1384	0.97	1568	1.22	1733	1.48	1884		
		53°F/68°F	1400	0.30	828	0.41	975	0.53	1103	0.64	1218	0.76	1323	0.89	1422	1.15	1600	1.42	1762	1.70	1910		
		41°F/51°F	1800	0.55	982	0.69	1108	0.83	1220	0.98	1325	1.12	1422	1.27	1513	1.58	1681	1.90	1834	2.23	1976		
		34°F/42°F	2200	0.93	1145	1.10	1254	1.27	1354	1.44	1449	1.61	1537	1.79	1621	2.15	1778	2.52	1923	2.90	2057		
		28°F/38°F	2600	1.45	1315	1.65	1410	1.85	1500	2.05	1585	2.25	1666	2.46	1744	1.35	1638	-	-	-	-		
25°F/31°F	3000	2.16	1489	2.39	1573	2.61	1654	2.84	1731	-	-	-	-	-	-	-	-	-	-				
100/125 End 100	E,F	41°F/51°F	1800	0.28	497	0.41	622	0.56	735	0.72	837	-	-	-	-	-	-	-	-	-			
		34°F/42°F	2200	0.43	553	0.58	662	0.75	762	0.93	855	1.12	942	1.33	1025	-	-	-	-	-			
		28°F/38°F	2600	0.63	614	0.81	710	1.00	800	1.20	885	1.41	965	1.63	1042	-	-	-	-	-			
		25°F/31°F	3000	0.91	680	1.11	766	1.32	847	1.54	1731	1.77	997	2.01	1068	2.51	1202	3.04	1328	3.60	1446		
		22°F/27°F	3400	1.26	748	1.48	825	1.72	899	1.96	970	2.21	1038	2.47	1104	3.01	1229	3.58	1347	4.17	1459		
		20°F/25°F	3704	1.58	802	1.83	873	2.08	942	2.34	1008	2.60	1072	2.88	1135	3.45	1254	4.04	1367	4.67	1474		
		- / 23°F	4100	2.09	873	2.35	938	2.63	1001	2.91	1062	3.20	1122	3.49	1180	4.10	1291	4.74	1398	-	-		
		- / 20°F	4630	2.93	969	3.23	1028	3.53	1085	3.84	1140	4.16	1194	4.48	1247	-	-	-	-	-	-		
		150/175 Start 175	C,D	100°F/117°F	1111	0.19	727	0.28	884	0.38	1023	0.48	1148	0.59	1262	0.70	1369	0.94	1563	1.21	1738	1.48	1899
				86°F/100°F	1296	0.27	793	0.37	937	0.47	1066	0.59	1184	0.71	1293	0.83	1395	1.09	1582	1.37	1752	1.66	1909
79°F/93°F	1400			0.32	832	0.42	970	0.54	1093	0.66	1208	0.78	1313	0.91	1412	1.18	1596	1.47	1763	1.78	1917		
62°F/72°F	1800			0.59	994	0.72	1109	0.86	1216	1.00	1316	1.15	1410	1.30	1500	1.62	1667	1.95	1823	2.29	1967		
51°F/59°F	2200			1.00	1166	1.16	1264	1.32	1356	1.49	1444	1.66	1529	1.84	1610	2.20	1762	2.57	1906	2.96	2041		
43°F/50°F	2600			1.58	1344	1.76	1429	1.95	1510	2.14	1589	2.34	1664	2.54	1737	2.95	1877	-	-	-	-		
37°F/43°F	3000			2.35	1526	2.57	1600	2.78	1673	3.00	1743	-	-	-	-	-	-	-	-	-	-		
150/175	E,F	86°F/100°F	1296	-	-	0.25	609	0.37	734	-	-	-	-	-	-	-	-	-	-	-			
		79°F/93°F	1400	0.17	474	0.28	615	0.40	737	-	-	-	-	-	-	-	-	-	-	-			
		62°F/72°F	1800	0.28	526	0.41	650	0.55	760	0.70	859	0.85	952	-	-	-	-	-	-	-			
		51°F/59°F	2200	0.44	588	0.59	697	0.75	796	0.91	887	1.09	972	1.27	1052	1.67	1201	-	-	-			
		43°F/50°F	2600	0.67	657	0.83	753	1.01	842	1.19	925	1.39	1004	1.59	1078	2.02	1218	2.47	1348	2.96	1469		
		37°F/43°F	3000	0.96	729	1.15	815	1.35	895	1.55	972	1.76	1044	1.98	1114	2.45	1245	2.94	1368	3.45	1483		
		33°F/38°F	3400	1.35	804	1.55	881	1.77	955	2.00	1025	2.23	1092	2.47	1157	2.96	1280	3.49	1396	4.03	1505		
		29°F/34°F	3800	1.82	880	2.05	951	2.29	1018	2.53	1083	2.79	1146	3.04	1206	3.58	1322	4.14	1431	4.72	1535		
		26°F/31°F	4200	2.40	959	2.66	1023	2.92	1085	3.18	1145	3.45	1204	3.73	1260	4.30	1369	4.90	1472	-	-		
		24°F/28°F	4700	3.30	1058	3.58	1116	3.87	1172	4.16	1227	4.46	1281	4.76	1333	-	-	-	-	-	-		
21°F/25°F	5200	4.40	1158	4.71	1212	-	-	-	-	-	-	-	-	-	-	-	-	-	-				
200/225 Start 225	C,D	100°F/113°F	1481	0.36	871	0.48	1016	0.60	1144	0.73	1259	0.85	1366	0.99	1465	1.26	1646	1.54	1808	1.84	1958		
		89°F/100°F	1667	0.48	943	0.61	1078	0.75	1198	0.88	1309	1.03	1411	1.17	1507	1.47	1682	1.77	1842	2.09	1988		
		85°F/95°F	1750	0.54	975	0.68	1106	0.82	1224	0.96	1332	1.11	1433	1.26	1527	1.57	1700	1.88	1857	2.21	2003		
		74°F/83°F	2000	0.76	1077	0.92	1197	1.08	1306	1.24	1407	1.40	1502	1.57	1592	1.91	1758	2.26	1910	2.62	2051		
		66°F/74°F	2250	1.04	1181	1.21	1291	1.39	1393	1.57	1488	1.75	1577	1.94	1663	2.31	1822	2.69	1969	-	-		
		59°F/67°F	2500	1.38	1288	1.57	1389	1.77	1484	1.97	1573	2.17	1658	2.37	1739	2.78	1892	-	-	-	-		
		54°F/61°F	2750	1.79	1396	2.00	1490	2.22	1579	2.44	1663	2.66	1743	2.88	1820	-	-	-	-	-	-		
		49°F/56°F	3000	2.28	1506	2.51	1593	2.75	1677	2.98	1756	-	-	-	-	-	-	-	-	-	-		
200/225	E,F	85°F/95°F	1750	0.29	594	0.43	723	0.58	838	0.75	944	0.94	1042	1.14	1134	1.58	1303	2.07	1458	2.60	1600		
		74°F/83°F	2000	0.40	642	0.54	759	0.71	866	0.88	966	1.08	1058	1.28	1146	1.74	1309	2.23	1458	2.78	1595		
		59°F/67°F	2500	0.68	746	0.85	845	1.04	938	1.23	1025	1.45	1108	1.67	1188	2.15	1337	2.67	1475	3.24	1604		
		49°F/56°F	3000	1.09	857	1.29	942	1.50	1024	1.72	1101	1.95	1176	2.19	1248	2.71	1384	3.27	1511	3.86	1632		
		42°F/48°F	3500	1.66	972	1.88	1047	2.12	1119	2.36	1188	2.61	1255	2.88	1320	3.43	1455	4.03	1563	-	-		
		37°F/42°F	4000	2.40	1091	2.65	1157	2.91	1221	3.18	1284	3.46	1345	3.75	1404	4.35	1518	4.98	1628	-	-		
		33°F/37°F	4500	3.34	1211	3.62	1270	3.91	1329	4.21	1385	4.51	1441	4.82	1495	-	-	-	-	-	-		
		30°F/33°F	5000	4.52	1332	4.82	1387	-	-	-	-	-	-	-	-	-	-	-	-	-	-		
200/225	G,H	85°F/95°F	1750	0.20	425	0.33	546	0.48	653	-	-	-	-	-	-	-	-	-	-	-			
		74°F/83°F	2000	0.26	449	0.40	562	0.56	662	0.74	754	-	-	-	-	-	-	-	-	-			
		59°F/67°F	2500	0.42	507	0.58	603	0.75	692	0.94	774	1.16	851	1.38	925	-	-	-	-	-			
		49°F/56°F	3000	0.65	571	0.83	654	1.02	732	1.23	807	1.45	877	1.69	944	2.21	1071	-	-	-			
		42°F/48°F	3500	0.97	639	1.17	713	1.38	782	1.60	850	1.84	914	2.10	975	2.64	1093	3.23	1202	3.86	1307		
		37°F/42°F	4000	1.38	710	1.60	776	1.83	839	2.08	899	2.34	958	2.60	1014	3.18	1123	3.80	1226	4.46	1324		
		33°F/37°F	4500	1.90	783	2.14	842	2.40	899	2.66	955	2.94	1008	3.23	1061	3.84	1161	4.48	1258	-	-		
		30°F/33°F	5000	2.54	858	2.81	911	3.08	963	3.37	1014	3.67	1064	3.98	1112	4.62	1206	-	-	-	-		
27°F/30°F	5500	3.32	933	3.61	982	3.91	1030	4.22	1077	4.54	1123	4.87	1168	-	-	-	-	-	-				
25°F/28°F	6000	4.25	1009	4.57	1054	4.89	1099	-	-	-	-	-	-	-	-	-	-	-	-				

① Total static pressure should include external static pressure and accessory / option static pressure from Table 39.1. Unit internal resistance has been included in the unit performance tables.

② Brake Horsepower and RPM values are approximate values only. Pressures.

It the AccuSpec selection software for values other than listed CFM / static pressures.</



# GENERAL PERFORMANCE DATA

Table 42.1 - Unit Performance Tables ① ②

Unit Size	Digit 16	Air Temp Rise	CFM	Total Static Pressure Inches "W.C.																			
				0.25		0.50		0.75		1.00		1.25		1.50		2.00		2.50		3.00			
				BHP	RPM	BHP	RPM	BHP	RPM	BHP	RPM	BHP	RPM	BHP	RPM	BHP	RPM	BHP	RPM	BHP	RPM		
500/600 Start 600	G or H →	120°F / -	3086	0.62	529	0.82	620	1.03	703	1.26	779	1.50	849	1.75	916	2.28	1038	2.84	1149	3.44	1252		
		106°F / -	3500	0.84	575	1.06	658	1.30	736	1.54	807	1.80	874	2.07	937	2.63	1054	3.23	1160	3.86	1262		
		100°F / 120°F	3704	0.97	598	1.20	678	1.45	753	1.70	822	1.97	887	2.25	949	2.83	1064	3.44	1172	4.09	1268		
		93°F / 111°F	4000	1.18	633	1.43	709	1.69	779	1.96	846	2.24	908	2.53	968	3.14	1080	3.78	1183	4.45	1279		
		82°F / 99°F	4500	1.61	693	1.88	762	2.17	827	2.46	889	2.77	948	3.09	1001	3.74	1110	4.43	1208	-	-		
		74°F / 89°F	5000	2.13	755	2.43	818	2.75	878	3.07	936	3.40	991	3.74	1044	4.44	1145	-	-	-	-		
		67°F / 81°F	5500	2.77	818	3.10	876	3.44	932	3.79	986	4.15	1038	4.51	1088	-	-	-	-	-	-		
		62°F / 74°F	6000	3.53	882	3.89	936	4.25	988	4.63	1038	-	-	-	-	-	-	-	-	-	-		
500/600 Start 600	I, J, K →	120°F / -	3086	0.46	401	0.69	496	0.95	580	1.23	657	-	-	-	-	-	-	-	-	-			
		100°F / 120°F	3704	0.69	443	0.95	527	1.23	604	1.54	675	-	-	-	-	-	-	-	-	-			
		93°F / 111°F	4000	0.82	464	1.09	544	1.39	618	1.71	686	2.05	749	2.42	810	-	-	-	-	-			
		74°F / 89°F	5000	1.43	542	1.75	609	2.09	673	2.46	733	2.84	790	3.24	844	4.09	946	5.01	1041	-	-		
		62°F / 74°F	6000	2.31	624	2.68	682	3.07	738	3.48	791	3.91	842	4.35	891	5.29	984	6.28	1072	7.33	1155		
		53°F / 63°F	7000	3.51	709	3.94	760	4.38	809	4.84	857	5.31	903	5.80	947	6.82	1032	7.90	1113	9.03	1191		
		46°F / 56°F	8000	5.09	797	5.57	842	6.07	886	6.58	928	7.10	970	7.64	1010	8.75	1089	9.92	1163	11.13	1235		
		41°F / 49°F	9000	7.11	885	7.65	926	8.20	965	8.76	1001	9.33	1042	9.92	1079	11.13	1151	12.38	1220	13.69	1287		
500/600 Start 500	L →	- / 44°F	10000	9.62	975	10.21	1012	10.81	1048	11.43	1083	12.05	1118	12.69	1152	14.00	1218	15.35	1283	-	-		
		- / 43°F	10400	10.77	1011	11.38	1046	12.01	1081	12.64	1115	13.29	1149	13.95	1182	15.30	1247	-	-	-	-		
		- / 40°F	11000	12.66	1065	13.31	1099	13.97	1132	14.64	1164	15.32	1197	16.01	1228	17.42	1290	-	-	-	-		
		- / 40°F	11111	13.04	1075	13.69	1109	14.36	1141	15.03	1174	15.72	1205	16.41	1237	17.83	1298	-	-	-	-		
		62°F / 74°F	6000	1.69	512	1.97	565	2.26	615	2.57	664	2.89	710	3.23	755	-	-	-	-	-	-		
		53°F / 63°F	7000	2.57	580	2.89	626	3.22	671	3.56	714	3.92	756	4.29	797	5.06	874	-	-	-	-		
		46°F / 56°F	8000	3.73	650	4.09	691	4.46	731	4.84	770	5.23	808	5.64	845	6.47	916	7.35	984	-	-		
		41°F / 49°F	9000	5.21	721	5.60	758	6.01	795	6.43	830	6.86	864	7.30	898	8.21	964	9.16	1027	10.14	1088		
700/800 Start 800	G or H →	- / 44°F	10000	7.04	793	7.48	827	7.93	860	8.39	882	8.85	924	9.33	955	10.31	1016	11.33	1074	12.38	1131		
		- / 43°F	10400	7.88	823	8.34	855	8.80	887	9.28	918	9.76	949	10.25	979	11.26	1038	12.31	1095	13.38	1150		
		- / 40°F	11000	9.27	866	9.75	897	10.24	927	10.74	957	11.24	986	11.76	1015	12.81	1071	13.90	1126	-	-		
		- / 40°F	11111	9.54	874	10.03	905	10.52	935	11.02	964	11.53	993	12.05	1022	13.12	1078	14.21	1132	-	-		
		120°F / -	4321	1.51	685	1.80	760	2.11	830	2.43	896	2.77	958	3.13	1018	3.88	1131	4.69	1236	-	-		
		115°F / -	4500	1.68	708	1.98	780	2.30	847	2.63	912	2.98	973	3.34	1032	4.11	1142	4.94	1245	-	-		
		105°F / 120°F	4938	2.15	763	2.48	89	2.82	893	3.17	953	3.54	1011	3.93	1066	4.74	1172	-	-	-	-		
		104°F / 119°F	5000	2.23	770	2.55	836	2.90	899	3.26	959	3.63	1016	4.02	1072	4.83	1176	-	-	-	-		
700/800 Start 800	I, J, K →	94°F / 108°F	5500	2.89	834	3.25	895	3.62	953	4.00	1009	4.40	1063	4.81	1116	-	-	-	-	-			
		86°F / 99°F	6000	3.68	900	4.06	956	4.46	1010	4.87	1062	-	-	-	-	-	-	-	-	-			
		80°F / 91°F	6500	4.61	965	-	-	-	-	-	-	-	-	-	-	-	-	-	-	-	-		
		120°F / -	4321	0.87	443	1.14	421	1.42	591	1.72	657	2.04	717	2.37	774	3.08	879	3.84	974	4.65	1063		
		104°F / 119°F	5000	1.26	488	1.55	558	1.87	623	2.20	683	2.54	740	2.90	794	3.66	894	4.47	985	5.33	1071		
		86°F / 99°F	6000	2.02	558	2.36	619	2.73	677	3.10	731	3.49	782	3.89	832	4.73	924	5.62	1010	6.55	1091		
		65°F / 74°F	8000	4.44	707	4.89	755	5.35	801	5.82	845	6.30	888	6.79	930	7.81	1009	8.87	1085	9.96	1156		
		58°F / 66°F	9000	6.19	784	6.69	827	7.20	869	7.72	909	8.25	949	8.79	987	9.90	1061	11.04	1131	12.23	1199		
700/800 Start 800	L →	52°F / 59°F	10000	8.36	861	8.91	901	9.47	939	10.04	976	10.62	1012	11.21	1048	12.42	1117	13.66	1183	14.93	1246		
		47°F / 54°F	11000	11.00	940	11.60	976	12.22	1011	12.84	1045	13.47	1079	14.11	1112	15.41	1176	16.74	1238	-	-		
		43°F / 49°F	12000	14.16	1019	14.81	1052	15.48	1085	16.15	1117	16.83	1148	17.52	1179	18.92	1239	-	-	-	-		
		40°F / 46°F	13000	17.88	1098	18.59	1129	19.30	1159	-	-	-	-	-	-	-	-	-	-	-	-		
		65°F / 74°F	8000	3.26	566	3.60	611	3.95	654	4.31	696	4.67	736	5.05	774	5.84	848	6.66	918	7.51	984		
		58°F / 66°F	9000	4.54	626	4.92	667	5.30	706	5.70	744	6.10	780	6.52	816	7.37	885	8.25	950	9.17	1012		
		52°F / 59°F	10000	6.13	687	6.54	724	6.97	760	7.40	794	7.85	828	8.30	861	9.22	925	10.17	987	11.15	1046		
		47°F / 54°F	11000	8.06	749	8.52	782	8.98	815	8.45	847	9.93	879	10.42	910	11.41	969	12.43	1027	13.48	1083		
End 700	→	47°F / 54°F	11050	8.17	752	8.62	785	9.09	818	9.56	850	10.04	881	10.53	912	11.53	972	12.56	1029	13.61	1084		
		43°F / 49°F	12000	10.37	811	10.86	842	11.37	872	11.88	902	12.40	931	12.92	960	13.99	1016	15.08	1070	16.20	1123		
		40°F / 46°F	13000	13.09	873	13.63	902	14.17	930	14.72	958	15.27	986	15.83	1013	16.98	1065	18.14	1116	19.33	1166		
		- / 42°F	14000	16.26	936	16.83	963	17.41	989	18.00	1015	18.59	1041	19.19	1066	-	-	-	-	-	-		
		- / 41°F	14500	18.02	968	18.61	994	19.21	1019	19.82	1045	-	-	-	-	-	-	-	-	-	-		
		840/960 End 840	I, J, K →	120°F / -	6481	2.72	630	3.09	685	3.48	736	3.88	785	4.30	832	4.72	876	5.60	960	6.52	1038	7.48	1112
		111°F / -		7000	3.36	672	3.76	723	4.17	772	4.60	818	5.04	863	5.49	905	6.42	986	7.38	1061	8.39	1133	
		105°F / 120°F		7407	3.93	705	4.35	754	4.79	800	5.23	845	5.69	888	6.16	929	7.13	1007	8.13	1081	9.17	1151	
97°F / 111°F	8000	4.87		754	5.33	799	5.90	843	6.27	885	6.76	926	7.26	965	8.28	1040	9.33	1111	10.43	1179			
86°F / 99°F	9000	6.80		837	7.31	878	7.83	918	8.36	956	8.90	994	9.44	1030	10.56	1100	11.71	1166	12.90	1230			
78°F / 89°F	10000	9.20		921	9.76	958	10.33	995	10.91	1030	11.50	1065	12.10	1099	13.32	1164	14.56	1226	-	-			
70°F / 80°F	1105																						

# BLOWER SHEAVE ASSEMBLY DATA

## Adjusting the Blower Drive Sheave Setting

All units include a sheave assembly indicated by Digit 19 of the model nomenclature. Within that assembly are the fixed blower sheave, adjustable motor sheave, and belt(s) to provide a method of adjusting the blower speed to balance the airflow based on actual external static pressure for the installation. The motor sheave is adjusted at the factory for external static conditions indicated on the order detail, however actual external static often varies from design, resulting in a need to adjust the equipment to provide correct design airflow.

To determine how many turns open the motor sheave should be set for:

1. Locate the unit Model Identification Plate and identify the following model number digits:
  - a. Digits 4-6 = Model Size
  - b. Digit 16 = Blower Size
  - c. Digit 19 = Sheave Arrangement
2. Use Table 39.1 to determine the individual static pressure drops for any features included on the unit for the design airflow. Add those and the design external static pressure to calculate the total static pressure.
3. Use Table 40.1 through Table 42.1 to determine the blower speed (RPM) required to meet the job requirements.
4. Use Table 44.1 to determine the RPM range and approximately blower speeds for each 1/2 turn open of the adjustable motor sheave. Find the RPM that is closest to one value shown to determine the turns open and set the motor sheave as described in the section "Blower Adjustments" on page page 26

**Figure 43.1 - Blower Section**

## Example:

Determine motor sheave turns open for a unit operating at 4000 CFM with a design external static pressure (ESP) of 0.60"W.C. as follows:

1. From the Model Nomenclature:
  - a. Model size (Model Digit 4-6) = 400
  - b. Blower size (Model Digit 16) = E
  - c. Sheave arrangement (Model Digit 19) = J
2. From Table 39.1, the unit includes 2" Farr 30/30 Filters (0.08"W.C. static) and Rainhood & Birdscreen (0.07"W.C. static). Total static pressure is  $0.08+0.07+0.60=0.75$ "W.C.
3. From Table 41.1, the blower speed is 1078 RPM.
4. From Table 44.1, the blower range is 1029-1332 RPM. The closest value to 1078 RPM in the row of Blower RPM by Sheave Turns Open is 1090 RPM, which corresponds to 4.0 turns open.

If actual job ESP after installation was measured at 0.75"W.C., the process above would be repeated with the new TSP of 0.90"W.C.

	<b>SHOP DRAWING REVIEW</b>	
	<b>PER M/E SPECIFICATIONS SECTIONS</b>	
DATE	PROJECT No.	
<b>2026/04/29</b>	<b>24333-08</b>	
<input type="checkbox"/> NOT REVIEWED	<input checked="" type="checkbox"/> REVIEWED	
<input type="checkbox"/> RESUBMIT	<input type="checkbox"/> REVIEWED AS MODIFIED	
<input type="checkbox"/> NOT SPECIFIED BY MCW, REVIEWED FOR MEP ONLY		
ELECTRICAL REVIEWER:	MECHANICAL REVIEWER:	
R.A. _____	TT _____	

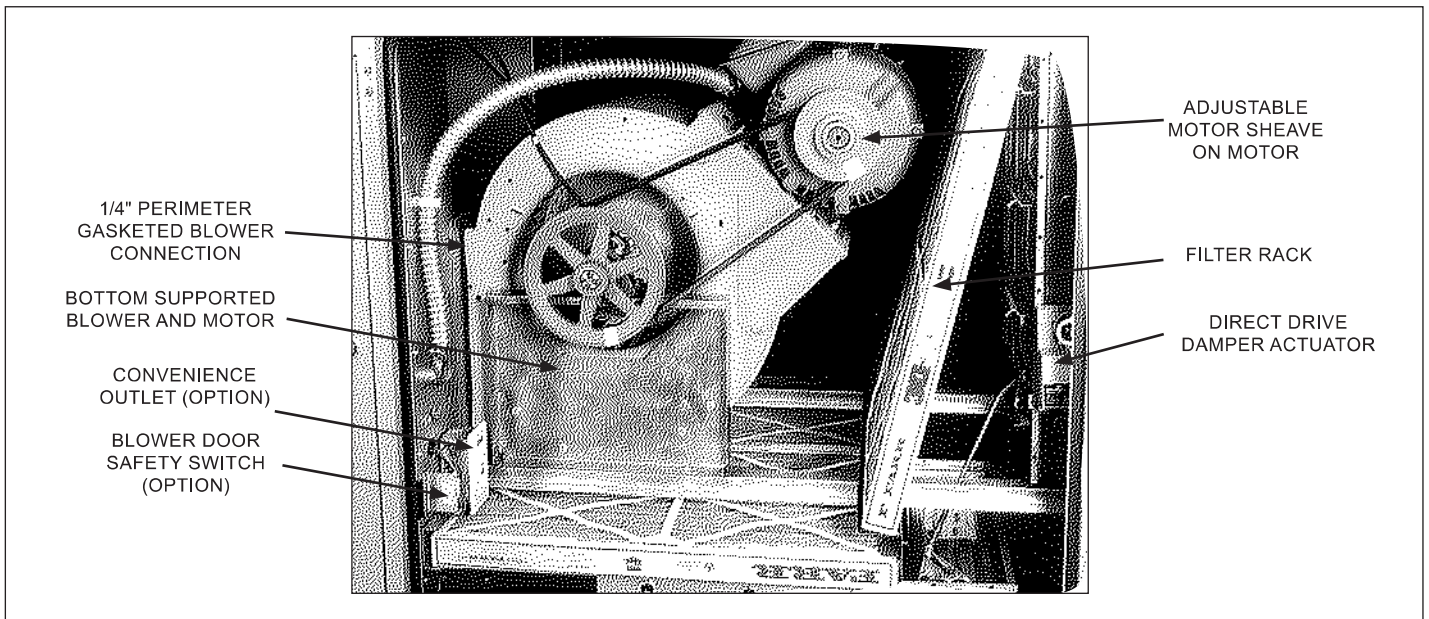

# BLOWER SHEAVE ASSEMBLY DATA

Table 44.1 - Sheave Assembly Data

Blower Type Digit 16	Sheave Digit 19	RPM Range	Blower RPM by Sheave Turns Open Setting (Approx.)										
			0	0.5	1	1.5	2	2.5	3	3.5	4	4.5	5
<b>A or B</b> (9-7 Blower)	A, B	656-1001	1001	967	932	898	863	829	794	760	725	691	656
	C, D, E	978-1265	1265	1236	1208	1179	1150	1122	1093	1064	1035	1007	978
	F, G	1150-1561	1561	1520	1479	1438	1397	1356	1314	1273	1232	1191	1150
	H, I	1526-1858	1858	1825	1792	1758	1725	1692	1659	1626	1592	1559	1526
	J, K	1763-2147	2147	2109	2070	2032	1993	1955	1917	1878	1840	1801	1763
<b>C or D</b> (9-9 Blower)	A, B	656-1001	1001	967	932	898	863	829	794	760	725	691	656
	C, D, E	978-1265	1265	1236	1208	1179	1150	1122	1093	1064	1035	1007	978
	F, G, H	1150-1561	1561	1520	1479	1438	1397	1356	1314	1273	1232	1191	1150
	I, J, K	1526-1858	1858	1825	1792	1758	1725	1692	1659	1626	1592	1559	1526
	L, M, N	1763-2147	2147	2109	2070	2032	1993	1955	1917	1878	1840	1801	1763
<b>E or F</b> (12-12 Blower)	A, B	468-715	715	690	666	641	616	592	567	542	517	493	468
	C, D, E	644-874	874	851	828	805	782	759	736	713	690	667	644
	F, G, H	863-1078	1078	1057	1035	1014	992	971	949	928	906	885	863
	I, J, K, Q	1029-1332	1332	1302	1271	1241	1211	1181	1150	1120	1090	1059	1029
	L, M, N	1150-1438	1438	1409	1380	1352	1323	1294	1265	1236	1208	1179	1150
	O, P	1327-1659	1659	1626	1593	1559	1526	1493	1460	1427	1393	1360	1327
<b>G or H</b> (15-15 Blower)	A, B, C	410-625	625	604	582	561	539	518	496	475	453	432	410
	D, E, F	568-771	771	751	730	710	690	670	649	629	609	588	568
	G, H, I	767-958	958	939	920	901	882	863	843	824	805	786	767
	J, K, L, O	934-1136	1136	1116	1096	1075	1055	1035	1015	995	974	954	934
	M, N	1136-1380	1380	1356	1331	1307	1282	1258	1234	1209	1185	1160	1136
<b>I or J</b> (18-18 Blower with Under 15 HP Motor)	A, B, C	491-649	649	633	617	602	586	570	554	538	523	507	491
	D, E, F, G	586-744	744	728	712	697	681	665	649	633	618	602	586
	H, I, J	682-821	821	807	793	779	765	752	738	724	710	696	682
	K, L, M, N	821-1009	1009	990	971	953	934	915	896	877	859	840	821
	O, P, Q, R	995-1161	1161	1144	1128	1111	1095	1078	1061	1045	1028	1012	995
	S, T, U	1101-1285	1285	1267	1248	1230	1211	1193	1175	1156	1138	1119	1101
<b>K</b> (18-18 Blower with 15 HP Motor & Up)	A, B, G, H	826-1009	1009	991	972	954	936	918	899	881	863	844	826
	C, D, I, J	995-1161	1161	1144	1128	1111	1095	1078	1061	1045	1028	1012	995
	E, F, K, L	1101-1285	1285	1267	1248	1230	1211	1193	1175	1156	1138	1119	1101
	M, N	1232-1438	1438	1417	1397	1376	1356	1335	1314	1294	1273	1253	1232
<b>L</b> (20-18 Blower)	A, B	491-649	649	633	617	602	586	570	554	538	523	507	491
	C, D, E	626-765	765	751	737	723	709	696	682	668	654	640	626
	F, G, H, I, J, K	765-901	901	887	874	860	847	833	819	806	792	779	765
	L, M, N, O, P, Q	901-1059	1059	1043	1027	1012	996	980	964	948	933	917	901
	R, S, T, U, V	995-1161	1161	1144	1128	1111	1095	1078	1061	1045	1028	1012	995
	W, X, Y, Z	1101-1285	1285	1267	1248	1230	1211	1193	1175	1156	1138	1119	1101

**SHOP DRAWING REVIEW**  
PER M/E SPECIFICATIONS SECTIONS

DATE: **2026/04/29** PROJECT No.: **24333-08**

NOT REVIEWED                       REVIEWED  
 RESUBMIT                             REVIEWED AS MODIFIED  
 NOT SPECIFIED BY MCW, REVIEWED FOR MEP ONLY

ELECTRICAL REVIEWER: R.A.                      MECHANICAL REVIEWER: TT



# DIMENSIONS - UNIT

Figure 46.1 - Outdoor EXTENDED Blower Package Unit (Model Digit 2=B, Digit 16=I, J, K, or L) ⑤

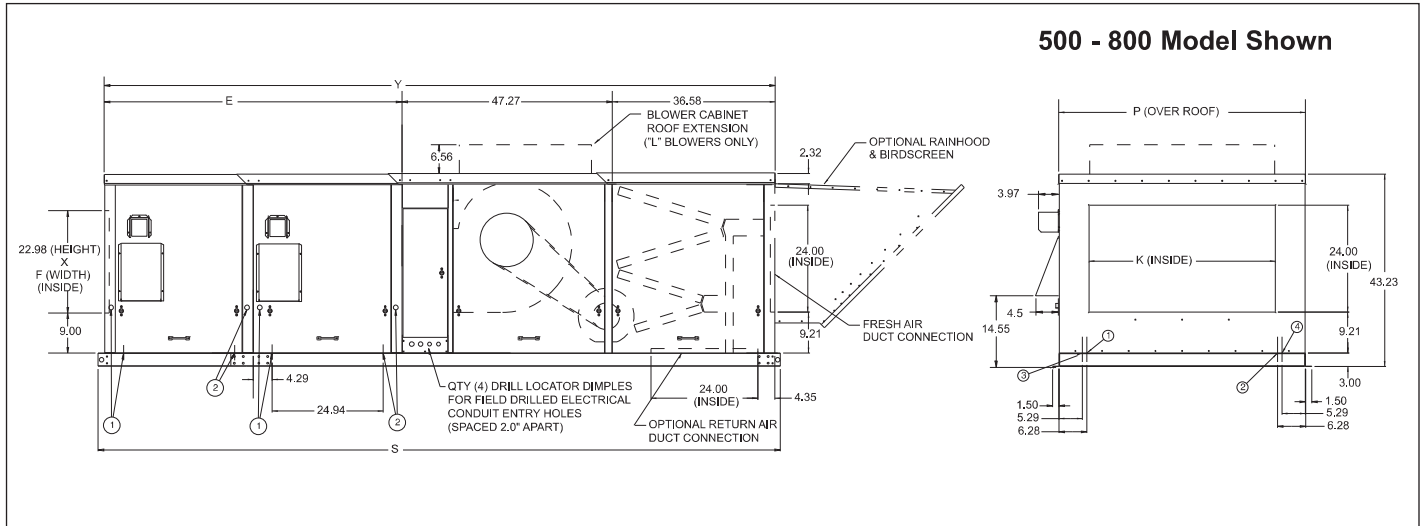

Figure 46.2 - Outdoor EXTENDED Blower Downturn Package Unit (Model Digit 2=D, Digit 16=I, J, K, or L) ⑤

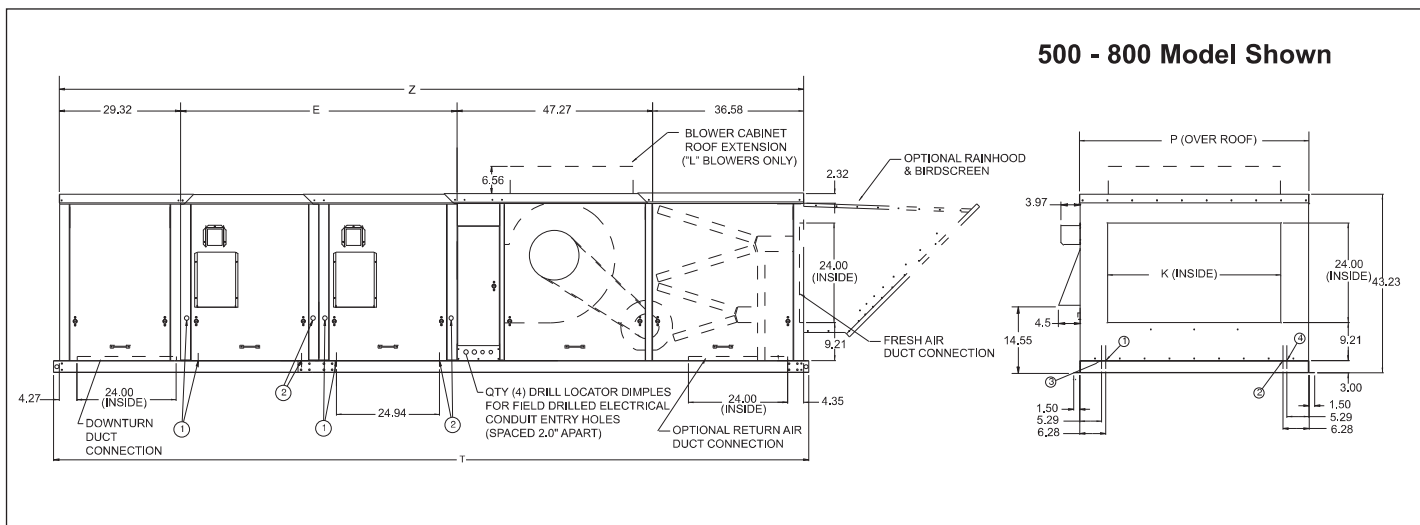

Table 46.1 - Outdoor EXTENDED Blower Unit (Model Digit 2=B or D, Digit 16=I, J, K, or L) ⑤

Model Size	Blower Type (Digit 16)	Furnace Qty	Dimensions (Inches)								Gas Conn.
			E	F	K	P	S	T	Y	Z	
250/300	I, J, or K	1	33.50	27.09	29.96	44.05	120.00	141.34	117.34	141.34	3/4
350/400	I, J, or K	1	33.50	38.60	41.90	55.57	120.00	141.34	117.34	141.34	3/4
500/600	I, J, K, or L	2	67.00	27.09	29.96	44.05	153.12	182.36	150.74	180.00	3/4
700/800	I, J, K, or L	2	67.00	38.60	41.90	55.57	153.12	182.36	150.74	180.00	3/4
840/960	I, J, K, or L	3	100.50	38.60	41.90	55.57	186.52	215.72	184.14	213.40	3/4

- ① For Right Hand Access Units - Location of drill locator dimples/knockouts for field drilled gas connection entry holes - one side of unit and one on bottom.
- ② For Left Hand Access Units - Location of drill locator dimples/knockouts for field drilled gas connection entry holes - one side of unit and one on bottom.
- ③ For Right Hand Access Units - Location of drill locator dimples for field drilled electrical connection, entry holes identical as side electrical connections.
- ④ For Left Hand Access Units - Location of drill locator dimples for field drilled electrical connection, entry holes identical as side electrical connections.
- ⑤ All dimensions shown are in inches.

**SHOP DRAWING REVIEW**

PER M/E SPECIFICATIONS SECTIONS

DATE: 2026/04/29 PROJECT No. 24333-08

NOT REVIEWED       REVIEWED  
 RESUBMIT       REVIEWED AS MODIFIED  
 NOT SPECIFIED BY MCW, REVIEWED FOR MEP ONLY

ELECTRICAL REVIEWER: R.A.      MECHANICAL REVIEWER: TT

# DIMENSIONS - UNIT

Figure 47.1 - Outdoor STANDARD Blower Cooling Package Unit (Model Digit 2=C, Digit 16=A through H) ⑤

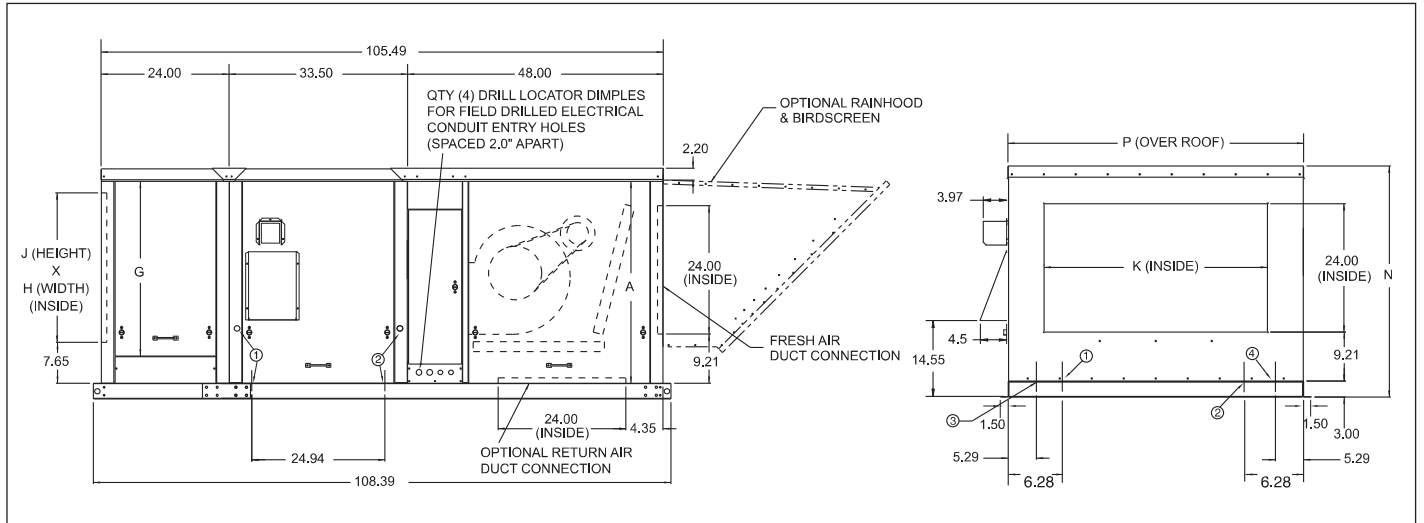

Figure 47.2 - Outdoor STANDARD Blower Cooling & Downturn Packaged Unit (Model Digit 2=P, Digit 16=A-H) ⑤

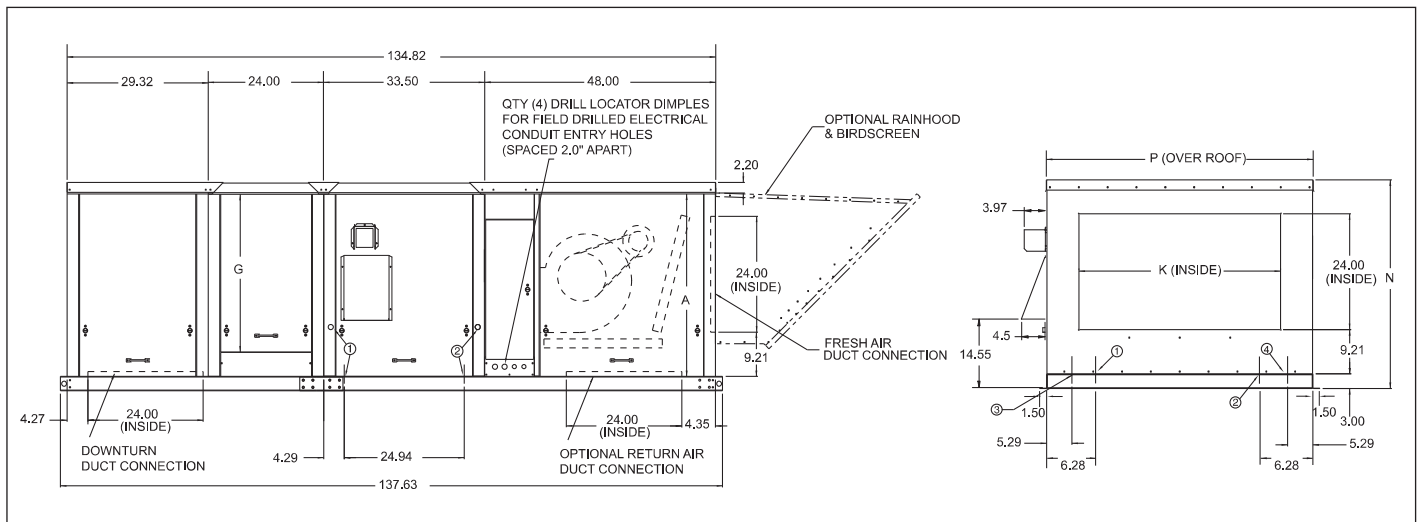

Table 47.1 - Outdoor STANDARD Blower Unit (Model Digit 2=C or P, Digit 16=A through H) ⑤

Model Size	Blower Type (Digit 16)	Dimensions (Inches)							Gas Conn.
		A	G	H	J	K	N	P	
100/125	All	33.75	28.75	21.00	25.00	20.02	39.23	34.56	1/2
150/175	All	33.75	28.75	24.00	25.00	23.99	39.23	38.82	1/2
200/225	All	37.75	32.75	27.00	28.00	23.99	43.23	40.94	1/2
250/300	E, F, G, or H	37.75	32.75	30.00	28.00	29.96	43.23	44.05	3/4
350/400	E, F, G, or H	37.75	32.75	42.00	28.00	41.90	43.23	55.57	3/4

- ① For Right Hand Access Units - Location of drill locator dimples/knockouts for field drilled gas connection entry holes - one side of unit and one on bottom.
- ② For Left Hand Access Units - Location of drill locator dimples/knockouts for field drilled gas connection entry holes - one side of unit and one on bottom.
- ③ For Right Hand Access Units - Location of drill locator dimples for field drilled electrical connection entry holes identical as side electrical connections.
- ④ For Left Hand Access Units - Location of drill locator dimples for field drilled electrical connection, entry holes identical as side electrical connections.
- ⑤ All dimensions shown are in inches.

SHOP DRAWING REVIEW  
PER ME SPECIFICATIONS SECTIONS

DATE: 2026/04/29 PROJECT No. 24333-08

<input type="checkbox"/> NOT REVIEWED	<input checked="" type="checkbox"/> REVIEWED
<input type="checkbox"/> RESUBMIT	<input type="checkbox"/> REVIEWED AS MODIFIED
<input type="checkbox"/> NOT SPECIFIED BY MCW, REVIEWED FOR MEP ONLY	
<b>ELECTRICAL REVIEWER:</b> R.A.	<b>MECHANICAL REVIEWER:</b> TT

# DIMENSIONS - UNIT

Figure 48.1 - Outdoor EXTENDED Blower Cooling Package Unit (Model Digit 2=C, Digit 16=I, J, K, or L) ⑤

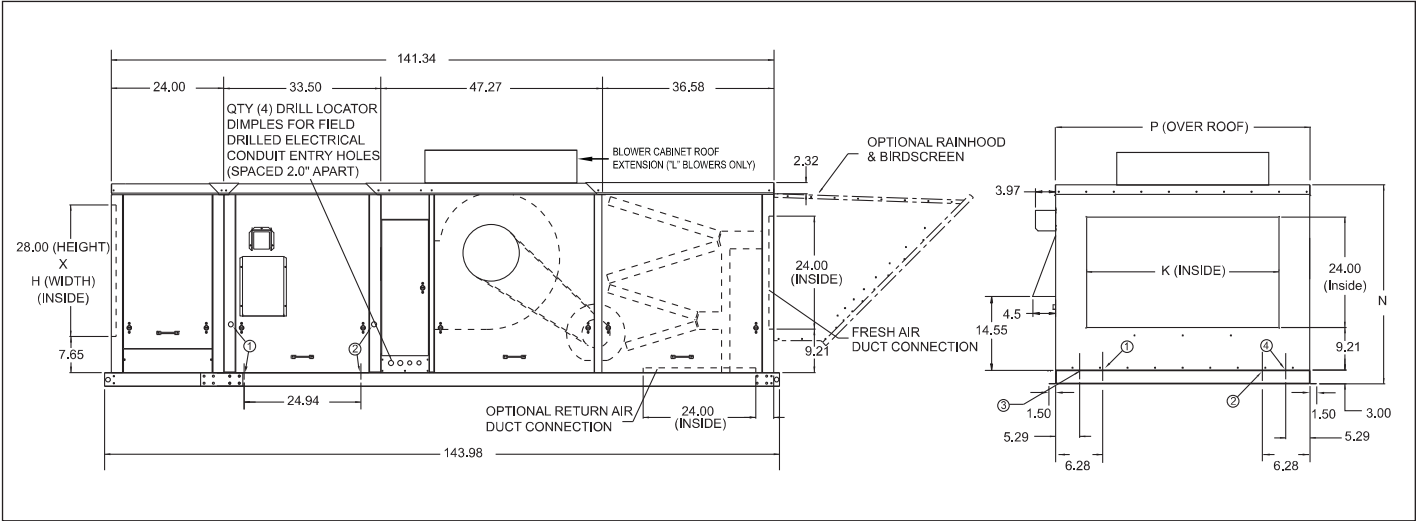

Figure 48.2 - Outdoor EXTENDED Blower Cooling & Downturn Unit (Model Digit 2=P, Digit 16=I, J, K, or L) ⑤

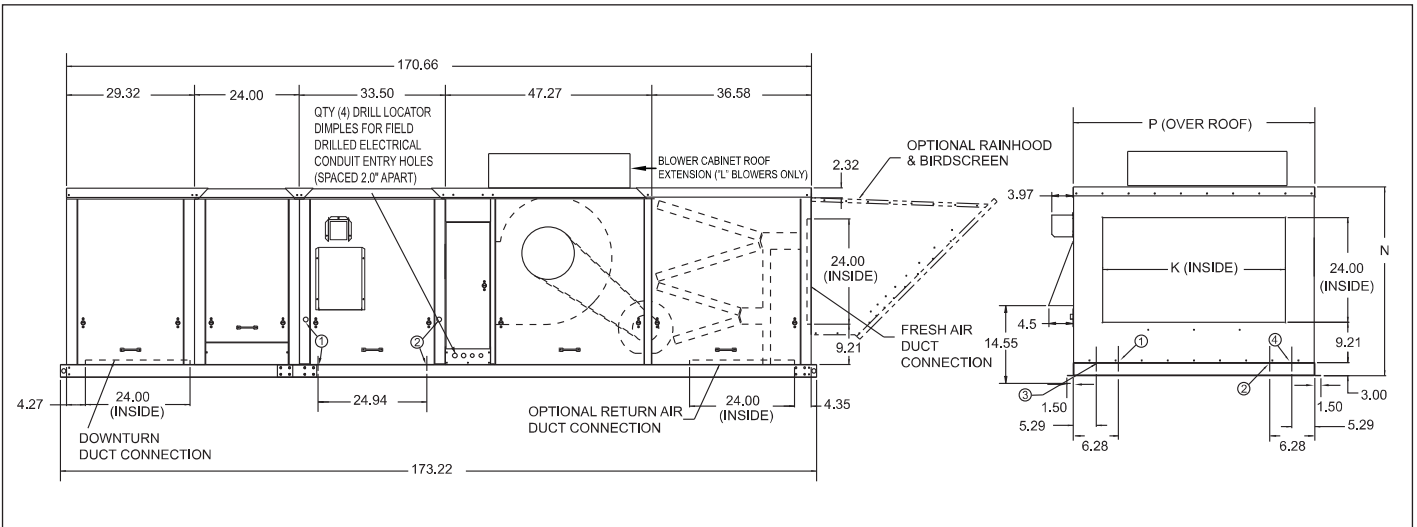

Table 48.1 - Outdoor EXTENDED Blower Unit (Model Digit 2=C or P, Digit 16=I, J, K, or L) ⑤

Model Size	Blower Type (Digit 16)	Dimensions (Inches)					Gas Conn.
		F	H	K	N	P	
250/300	I, J, or K	27.09	30.00	29.96	43.23	44.05	3/4
350/400	I, J, or K	38.60	42.00	41.90	43.23	55.57	3/4

- ① For Right Hand Access Units - Location of drill locator dimples/knockouts for field drilled gas connection entry holes - one side of unit and one on bottom.
- ② For Left Hand Access Units - Location of drill locator dimples/knockouts for field drilled gas connection entry holes - one side of unit and one on bottom.
- ③ For Right Hand Access Units - Location of drill locator dimples for field drilled electrical connection entry holes identical as side electrical connections.
- ④ For Left Hand Access Units - Location of drill locator dimples for field drilled electrical connection entry holes identical as side electrical connections.
- ⑤ All dimensions shown are in inches.

SHOP DRAWING REVIEW  
PER M/E SPECIFICATIONS SECTIONS

DATE: **2026/04/29** PROJECT No.: **24333-08**

NOT REVIEWED                       REVIEWED  
 RESUBMIT                               REVIEWED AS MODIFIED  
 NOT SPECIFIED BY MCW, REVIEWED FOR MEP ONLY

ELECTRICAL REVIEWER: **R.A.**                      MECHANICAL REVIEWER: **TT**

# DIMENSIONS - UNIT BASE

Figure 49.1 - Unit Base Dimensions ②

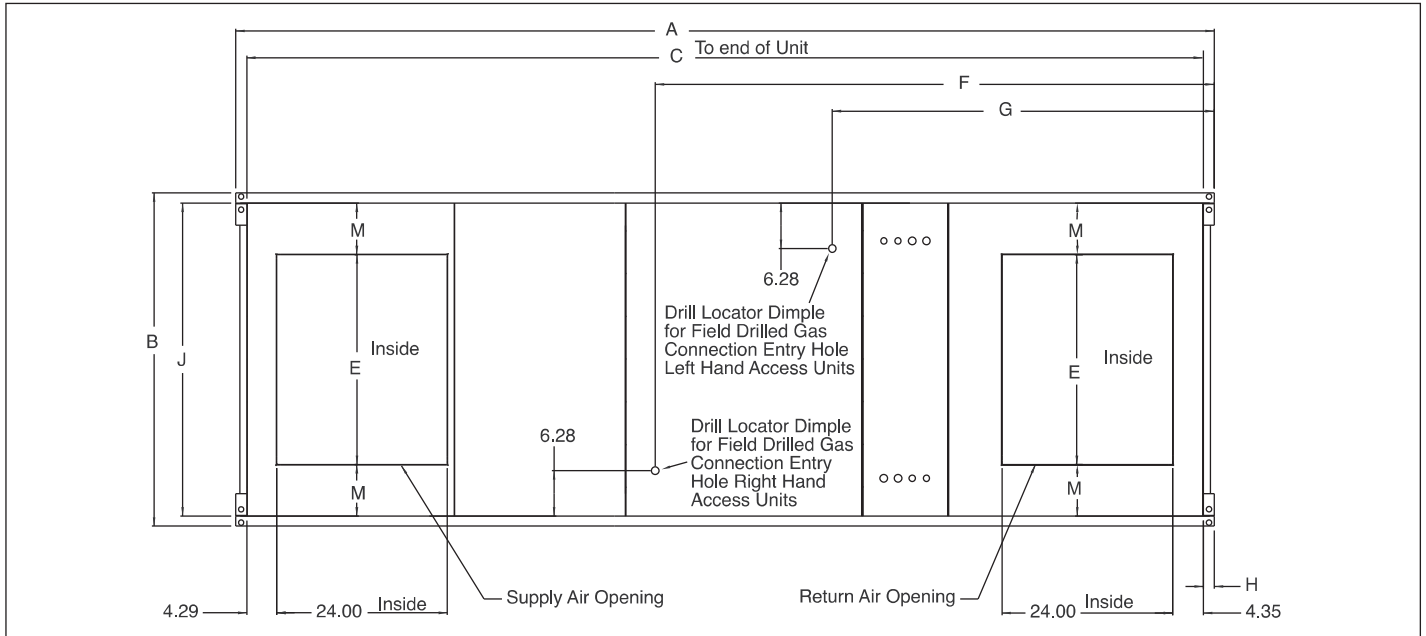

Table 49.1 - Outdoor Unit Base Rail Dimensions for Model Digit 2=B or D ②

Model Size	Blower Type (Digit 16)	Dimensions (Inches)										
		Digit 2=B		Digit 2=D		Digit 2=B or D						
		A	C	A	C	B	E	F ①	G ①	H	J	M
100/125	All	84.41	81.49	113.63	110.82	37.36	19.52	78.66	53.72	1.53	34.50	7.49
150/175	All	84.41	81.49	113.63	110.82	41.61	23.49	78.66	53.72	1.53	38.75	7.63
200/225	All	84.41	81.49	113.63	110.82	43.71	23.49	78.66	53.72	1.53	40.85	8.69
250/300	E,F,G, or H	84.41	81.49	113.63	110.82	46.75	29.46	78.66	53.72	1.53	43.89	7.21
250/300	I, J, or K	120.00	117.34	149.22	146.66	46.75	29.46	114.23	84.29	1.28	43.89	7.21
350/400	E,F,G, or H	84.41	81.49	113.63	110.82	58.27	41.40	78.66	53.72	1.53	55.41	7.00
350/400	I, J, or K	120.00	117.34	149.22	146.66	58.27	41.40	114.23	82.29	1.28	55.41	7.00
500/600	G or H	117.53	114.94	146.77	144.12	46.75	29.46	78.66	53.72	1.53	43.89	7.21
500/600	I, J, K, or L	153.12	150.74	182.36	180.00	46.75	29.46	114.23	82.29	1.28	43.89	7.21
700/800	G or H	117.53	114.94	146.77	144.12	58.27	41.40	78.66	53.72	1.53	55.41	7.00
700/800	I, J, K, or L	153.12	150.74	182.36	180.00	58.27	41.40	114.23	82.29	1.28	55.41	7.00
840/960	I, J, K, or L	186.52	184.14	215.77	213.40	58.27	41.40	114.23	82.29	1.28	55.41	7.00

Table 49.2 - Outdoor Unit Base Rail Dimensions Model Digit 2=C or P ②

Model Size	Blower Type (Digit 16)	Dimensions (Inches)										
		Digit 2=C		Digit 2=P		Digit 2=C or P						
		A	C	A	C	B	E	F	G	H	J	M
100/125	All	108.39	105.49	137.63	134.82	37.36	19.52	78.66	53.72	1.53	34.50	7.49
150/175	All	108.39	105.49	137.63	134.82	41.61	23.49	78.66	53.72	1.53	38.75	7.63
200/225	All	108.39	105.49	137.63	134.82	43.71	23.49	78.66	53.72	1.53	40.85	8.69
250/300	E,F,G, or H	108.39	105.49	137.63	134.82	46.75	29.46	78.66	53.72	1.53	43.89	7.21
250/300	I, J, or K	143.98	141.34	173.22	170.66	46.75	29.46	114.23	82.29	1.28	43.89	7.21
350/400	E,F,G, or H	108.39	105.49	137.63	134.82	58.27	41.40	78.66	53.72	1.53	55.41	7.00
350/400	I, J, or K	143.98	141.34	173.22	170.66	58.27	41.40	114.23	82.29	1.28	55.41	7.00

① Gas connection for 1st furnace. For Model sizes 500-800 add 33.5" for second furnace gas connection. For Model sizes 40-960 add 37.00" for second furnace gas connections.

② All dimensions shown are in inches.

**RESUBMIT**                       **REVIEWED AS MODIFIED**  
 **NOT SPECIFIED BY MCW, REVIEWED FOR MEP ONLY**  
**ELECTRICAL REVIEWER: R.A.**                      **MECHANICAL REVIEWER: TT**

# DIMENSIONS - ROOF CURBS

Figure 50.1 - Roof Curb Dimensions ②

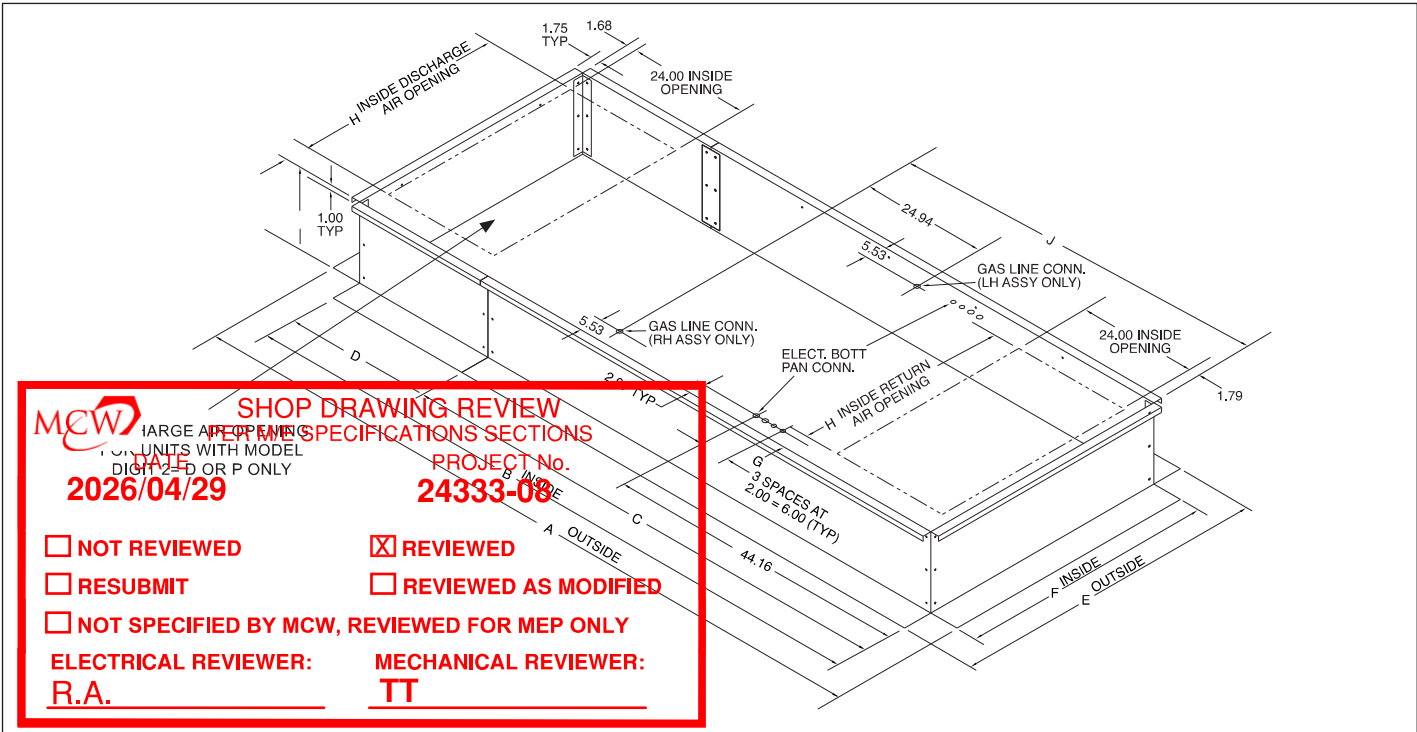

Table 50.1 - Roof Curb Dimensions Model Digit 2=B or D ②

Model Size	Blower Type (Digit 16)	Dimensions (Inches)												
		Digit 2=B				Digit 2=D				Digit 2=B or D				
		A	B	C	D	A	B	C	D	E	F	G	H	J ①
100/125	All	88.77	76.77	-	-	117.98	105.98	-	-	41.84	29.84	5.22	19.52	74.84
150/175	All	88.77	76.77	-	-	117.98	105.98	-	-	46.18	34.18	5.41	23.49	74.84
200/225	All	88.77	76.77	-	-	117.98	105.98	-	-	48.22	36.22	6.43	23.49	74.84
250/300	E,F,G, or H	88.77	76.77	-	-	117.98	105.98	-	-	51.25	39.25	4.96	29.46	74.84
250/300	I, J, or K	124.61	112.61	-	-	153.83	141.63	105.98	35.85	51.25	39.25	4.96	29.46	110.41
350/400	E,F,G, or H	88.77	76.77	-	-	117.98	105.98	-	-	62.76	50.76	4.74	41.40	74.84
350/400	I, J, or K	124.61	112.61	-	-	153.83	141.63	105.98	35.85	62.76	50.76	4.74	41.40	110.41
500/600	G or H	121.89	109.89	-	-	151.10	139.10	105.98	33.12	51.25	39.25	4.96	29.46	74.84
500/600	I, J, K, or L	157.74	145.74	105.98	39.76	186.98	174.98	105.98	69.00	51.25	39.25	4.96	29.46	110.41
700/800	G or H	121.89	109.89	-	-	151.10	139.10	105.98	33.12	62.76	50.76	4.74	41.40	74.84
700/800	I, J, K, or L	157.74	145.74	105.98	39.76	186.98	174.98	105.98	69.00	62.76	50.76	4.74	41.40	110.41
840/960	I, J, K, or L	191.14	179.14	105.98	73.16	220.39	208.39	105.98	102.41	62.76	50.76	4.74	41.40	110.41

Table 50.2 - Roof Curb Dimensions Model Digit 2=C or P ②

Model Size	Blower Type (Digit 16)	Dimensions (Inches)												
		Digit 2=C				Digit 2=P				Digit 2=C or P				
		A	B	C	D	A	B	C	D	E	F	G	H	J
100/125	All	112.74	100.74	-	-	141.98	129.98	100.74	29.24	41.84	29.84	5.22	19.52	74.84
150/175	All	112.74	100.74	-	-	141.98	129.98	100.74	29.24	46.18	34.18	5.41	23.49	74.84
200/225	All	112.74	100.74	-	-	141.98	129.98	100.74	29.24	48.22	36.22	6.43	23.49	74.84
250/300	E,F,G, or H	112.74	100.74	-	-	141.98	129.98	100.74	29.24	51.25	39.25	4.96	29.46	74.84
250/300	I, J, or K	148.59	136.59	105.98	30.61	177.83	165.83	105.98	59.85	51.25	39.25	4.96	29.46	110.41
350/400	E,F,G, or H	112.74	100.74	-	-	141.98	129.98	100.74	29.24	62.76	50.76	4.74	41.40	74.84
350/400	I, J, or K	148.59	136.59	105.98	30.61	177.83	165.83	105.98	59.85	62.76	50.76	4.74	41.40	110.41

① Gas connection for 1st furnace. For Model sizes 500-800 add 33.5" for second furnace gas connection. For Model sizes 840-960 add 33.50" and 67.00" for second and third furnace gas connections.

② All dimensions shown are in inches.

# DIMENSIONS - COOLING COILS

Figure 51.1 - DX Coil Drawing ③

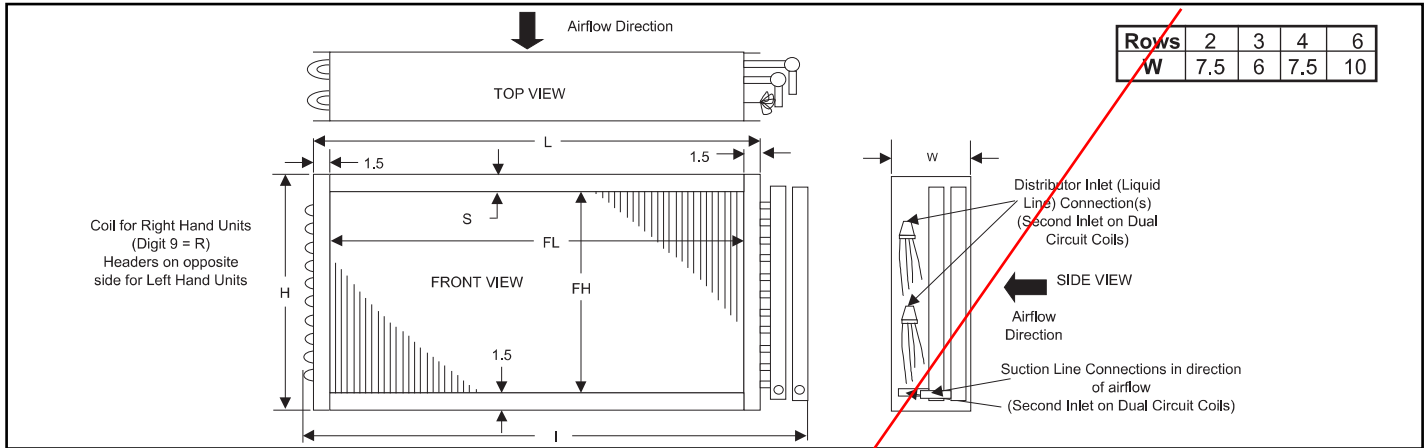

Table 51.1 - DX Coil Dimensions ③

Model Size	Cooling MBH	FH	H	S	DX - Single Circuit ①			DX - Dual Circuit ②		
					FL	I	L	FL	I	L
100/125	All	27.5	30.5	1.5	21	28	24	19.5	29.75	22.5
150/175	All	27.5	30.5	1.5	24	31	27	23	33.25	28.5
200/225	Below 185 MBH	32.5	34.5	0.5	27	34	30	25.5	35.75	28.5
	185 MBH & Up	32.5	34.5	0.5	27	34.5	30			
250/300	Below 185 MBH	32.5	34.5	0.5	30	37	33	28.5	38.75	31.5
	185 MBH & Up	32.5	34.5	0.5	30	37.5	33			
350/400	Below 185 MBH	32.5	34.5	0.5	42	49	45	40.25	50.5	43.25
	185 MBH & Up	32.5	34.5	0.5	42	49.5	45			

- ① Single Circuit DX coils have 1 each Suction Line and Liquid Lines. Refer to AccuSpec for line size diameters.
- ② Dual Circuit DX coils have 2 each Suction Line and Liquid Lines. Refer to AccuSpec for line size diameters.
- ③ All dimensions shown are in inches.

# DIMENSIONS - RAINHOOD, REMOTE PANEL & EVAPORATIVE COOLER

Figure 52.1 - Rainhood and Birdscreen Dimensions (inches)

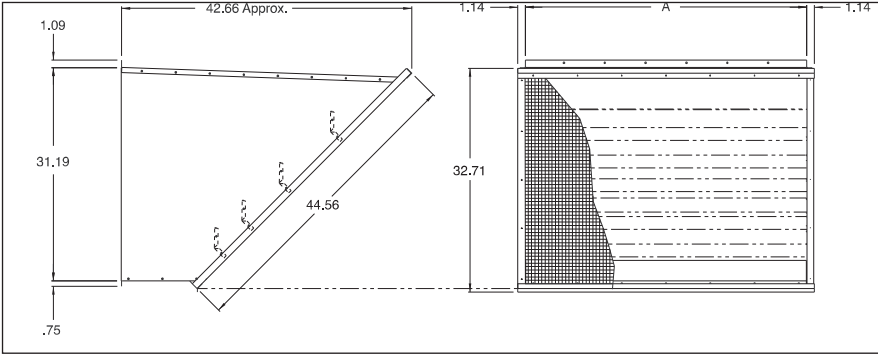

Table 52.1 - Rainhood and Birdscreen Dimensions (inches)

Rainhood & Birdscreen	
Model Size	A
100/125	31.94"
150/175	38.24"
200/225	38.24"
250/300	41.34"
350/400	52.85"
500/600	41.34"
700/800	52.85"
840/960	52.85"

Figure 52.2 - Evaporative Cooler (Model Digit 22=D)

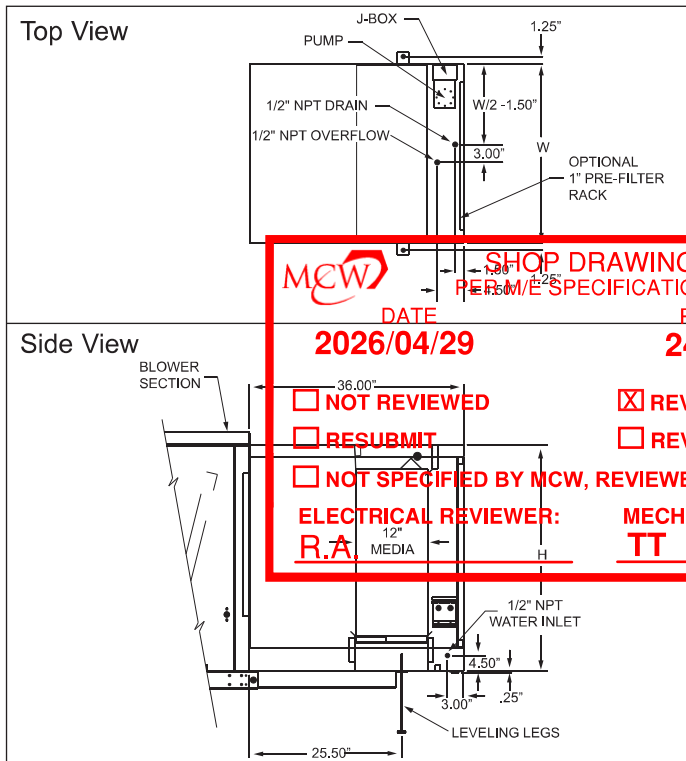
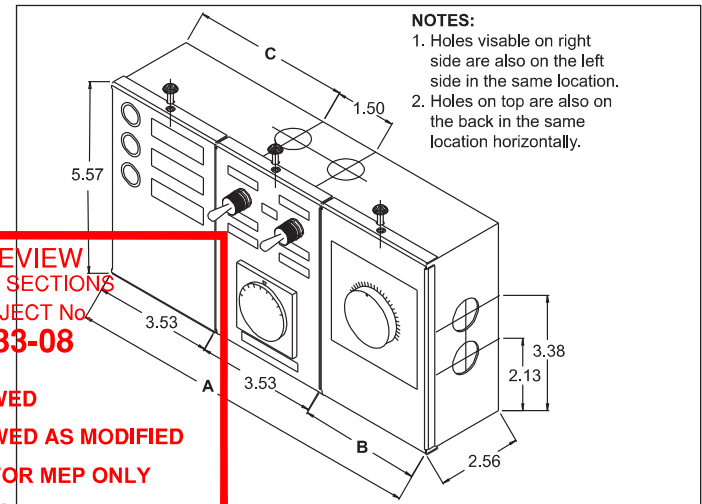

Figure 52.3 - Remote Panel Dimensions (inches)



**SHOP DRAWING REVIEW**  
PER M/E SPECIFICATIONS SECTIONS

DATE: **2026/04/29** PROJECT No: **24333-08**

NOT REVIEWED       REVIEWED  
 RESUBMIT       REVIEWED AS MODIFIED  
 NOT SPECIFIED BY MCW, REVIEWED FOR MEP ONLY

ELECTRICAL REVIEWER: **R.A.**      MECHANICAL REVIEWER: **TT**

Table 52.3 - Remote Panel Dimensions (inches)

Remote Panel Type	A	B	C
Light and Switch Panels Only	7.06"	-	2.81"
Light and Switch Panels with Single Stage Thermostat or Electronic Set Point Adjustor	10.60"	3.53"	4.58"
Light and Switch Panels with Two Stage Thermostat	13.09"	6.03"	5.82"

Table 52.2 - Evap Cooler Dimension, Performance, and Weight Data

Model Size	Blower Type (Digit 16)	H (in.)	W (in.)	Maximum Cooling CFM	Media Face Area (ft <sup>2</sup> )	Maximum Face Velocity (ft/min)	12" GlasDek Media (Digit 23 = D)	
							Dry Weight (lbs)	Op. Weight (lbs)
100/125	All	34	30	4000	5.0	800	159	295
150/175	All	34	36	5200	6.5	800	169	336
200/225	All	38	36	6000	7.5	800	174	341
250/300	E, F, G, or H	38	39	6500	8.1	800	182	363
250/300	I, J, or K	56	39	10400	13.0	800	214	404
350/400	E, F, G, or H	38	51	8500	10.6	800	228	473
350/400	I, J, or K	47	51	11050	13.8	800	244	496
500/600	G or H	38	39	6500	8.1	800	182	363
500/600	I, J, K or L	56	39	10400	13.0	800	214	404
700/800	G or H	38	51	8500	10.6	800	228	473
700/800	I, J, K or L	47	51	11050	13.8	800	244	496
840/960	I, J, K or L	47	51	11050	13.8	800	244	496

# WEIGHTS

Table 53.1 - Unit Operating Weights ①

Model Size	Blower Type (Digit 16)	Base Unit				Motor	Filters	Dampers		Rain-hood	Double Wall (all sections)				Evap Cooler
		Digit 2						Fresh Air Only	Fresh & Return Air		Digit 2				
		B	D	C	P						B	D	C	P	
100/125	All	474	578	584	688	See Motor Data	6	26	46	67	38	73	72	107	See Evaporative Cooler Data
150/175	All	511	621	626	736		6	29	52	70	43	78	77	112	
200/225	All	588	707	714	833		6	29	52	72	46	86	85	125	
250/300	E,F,G, or H	626	747	756	877		8	33	60	83	46	88	87	129	
250/300	I, J, or k	875	996	1005	1126		15	33	60	83	93	135	134	176	
350/400	E,F,G, or H	738	876	887	1025		12	38	70	90	53	102	101	150	
350/400	I, J, or k	1019	1057	1168	1306		17	38	70	90	96	145	144	193	
500/600	G or H	959	1080	n/a	n/a		8	33	60	83	46	88	n/a	n/a	
500/600	I, J, k, or L	1208	1329	n/a	n/a		15	33	60	83	93	135	n/a	n/a	
700/800	G or H	1153	1291	n/a	n/a		12	38	70	90	53	102	n/a	n/a	
700/800	I, J, k, or L	1352	1490	n/a	n/a		17	38	70	90	96	145	n/a	n/a	
840/960	I, J, k, or L	1767	1905	n/a	n/a		17	38	70	90	96	145	n/a	n/a	

① All weights in pounds and are approximate.

Table 53.2 - Motor Operating Weights ①

Digit 14 - Supply Voltage	Digit 18 - Motor Type	Digit 17 - Motor Size												
		A or L	B or M	C or N	D or P	E or Q	F or R	G or S	H or T	I or W	J or X	K or Y	V or Z	
		1/3	1/2	3/4	1	1-1/2	2	3	5	7-1/2	10	15	20	
A - 115/60/1ph	1 - ODP	25	23	25	32	40	49	81	-	-	-	-	-	
	5 - TE	25	28	30	37	45	49	83	-	-	-	-	-	
B - 208/60/1ph	1 - ODP	-	23	25	32	40	49	81	87	-	-	-	-	
	5 - TE	-	28	30	37	45	49	83	86	-	-	-	-	
C - 230/60/1ph	1 - ODP	25	23	25	32	40	49	81	87	-	-	-	-	
	5 - TE	25	28	30	37	45	49	83	86	-	-	-	-	
D - 208/60/3ph	1 - ODP	17	18	21	-	-	-	-	-	-	-	-	-	
	2 - ODP HE	-	-	-	83	94	99	83	94	141	126	220	250	
	5 - TE	15	23	26	-	-	-	-	-	-	-	-	-	
	6 - TE HE	-	-	-	68	66	66	92	99	158	200	259	368	
E - 230/60/3ph	1 - ODP	17	18	21	-	-	-	-	-	-	-	-	-	
	2 - ODP HE	-	-	-	40	46	54	87	94	130	126	217	250	
	5 - TE	15	23	30	-	-	-	-	-	-	-	-	-	
	6 - TE HE	-	-	-	53	66	67	92	117	194	213	322	368	
F - 460/60/3ph	1 - ODP	17	18	21	-	-	-	-	-	-	-	-	-	
	2 - ODP HE	-	-	-	40	46	54	87	94	130	126	217	250	
	5 - TE	15	23	30	-	-	-	-	-	-	-	-	-	
	6 - TE HE	-	-	-	53	66	66	92	117	194	213	322	368	
G - 575/60/3ph	1 - ODP	25	23	25	32	40	49	81	-	-	-	-	-	
	2 - ODP HE	-	-	-	83	94	99	83	94	141	126	220	250	
	5 - TE	15	23	30	-	-	-	-	-	-	-	-	-	
	6 - TE HE	-	-	-	68	66	67	92	99	158	200	259	368	

① All weights in pounds and are approximate.

NOT REVIEWED  
 REVIEWED  
 RESUBMIT  
 REVIEWED AS MODIFIED  
 NOT SPECIFIED BY MCW, REVIEWED FOR MEP ONLY

ELECTRICAL REVIEWER: R.A.      MECHANICAL REVIEWER: TT

# MAINTENANCE

## ⚠ WARNING

When servicing or repairing this equipment, use only factory-approved service replacement parts. A complete replacement parts list may be obtained by contacting Modine Manufacturing Company. Refer to the rating plate on the appliance for complete appliance model number, serial number, and company address. Any substitution of parts or controls not approved by the factory will be at the owner's risk.

## ⚠ AVERTISSEMENT

Pour l'entretien et les réparations de cet appareil, utilisez uniquement des pièces d'origine certifiées. Pour la liste complète des pièces de rechange, consultez Modine Manufacturing Company. Le numéro de modèle complet, le numéro de série et l'adresse du fabricant figurent sur la plaque signalétique fixée à l'appareil. Toute substitution de pièce ou de commande non approuvée par le fabricant sera aux risques du propriétaire.

## ⚠ CAUTION

Do not attempt to reuse any mechanical or electrical component which has been wet. Such component must be replaced.

## ⚠ ATTENTION

Ne tentez pas de réutiliser un composant mécanique ou électrique qui a été mouillé. Ces composants doivent être remplacés.

## IMPORTANT

To check most of the Possible Remedies in the troubleshooting guide listed in Table 58.1, refer to the applicable sections of the manual.

## IMPORTANT

Pour essayer la plupart des solutions possibles suggérées dans le guide de dépannage du Tableau 58.1 reportez-vous aux sections correspondantes du manuel.

All heating equipment should be serviced before each heating season to assure proper operations. The following items may be required to have more frequent service schedule based on the environment in which the unit is installed, and the frequency of the equipment operation.

### Electrical Wiring

The electrical wiring should be checked annually for loose connections or deteriorated insulation.

### Blower Assembly

The blower assembly includes the bearings, drive sheaves and belts. Blower bearings should be checked and lubricated based on the blower manufacturer's recommendations. Bearings should also be checked for any unusual wear and replaced if needed.

Drive sheaves should be checked at the same time the bearings are inspected. Check to make sure the sheaves are in alignment and are securely fastened to the blower and motor shafts. Belt

tension should be rechecked shortly after the unit has been installed to check for belt stretching. After the initial start-up, monthly checks are recommended.

### Filters

If the unit is supplied with a dirty filter switch and light, clean or replace the filters any time the dirty filter light comes on.

Units which do not have a dirty filter warning light should have the filters checked monthly. Clean or replace if necessary. In dirty atmospheres, filter maintenance may be required more often.

**Figure 54.1 - Filter Replacement Arrangement for STANDARD Blower Size (Model Digit 16=A through H)**

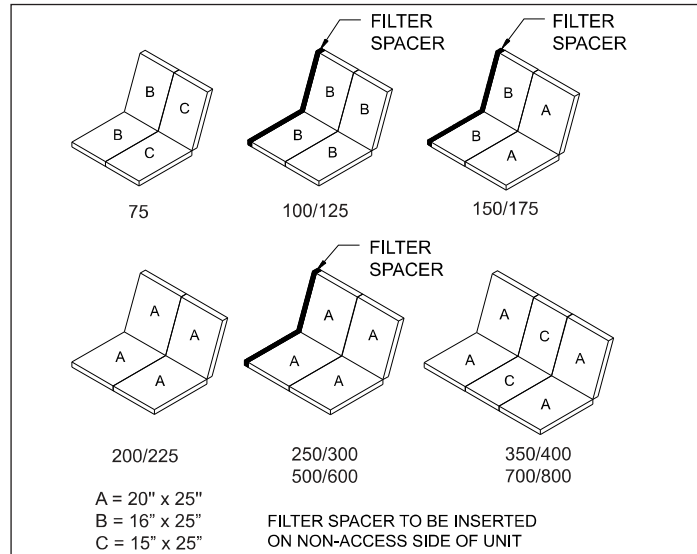

**Figure 54.2 - Filter Replacement Arrangement for EXTENDED Blower Size (Model Digit 16 = I, J, K, or L)**

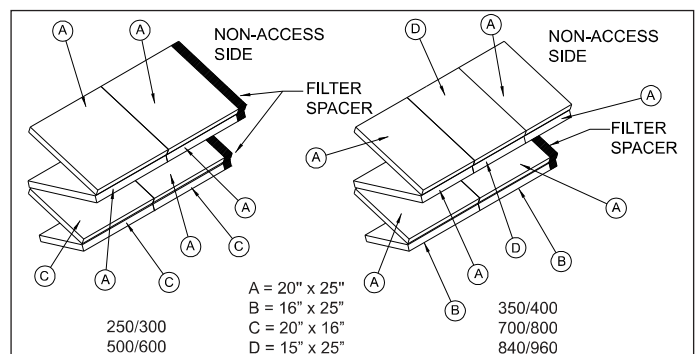

**SHOP DRAWING REVIEW**  
PER M/E SPECIFICATIONS SECTIONS

DATE: **2026/04/29** PROJECT No.: **24333-08**

NOT REVIEWED                       REVIEWED  
 RESUBMIT                               REVIEWED AS MODIFIED  
 NOT SPECIFIED BY MCW, REVIEWED FOR MEP ONLY

ELECTRICAL REVIEWER: R.A.                      MECHANICAL REVIEWER: TT

# MAINTENANCE

## Cooling Coil Maintenance

1. Periodically, inspect the coil for signs of corrosion and leaks. Repair and replacement of the coil and the connecting piping, valves, etc., must be performed as needed by a qualified technician.
2. Should the coil surface need cleaning, caution should be exercised in selecting the cleaning solution as well as the cleaning equipment. Improper selection can result in damage to the coil and/or health hazards. Cleaning solutions must not be corrosive or cause damage to copper tube/aluminum fin coils. Clean the coil from the leaving air-side so that foreign material will be washed out of the coil rather than pushed further in. Be sure to carefully read and follow the cleaning fluid manufacturer's recommendations before using any cleaning fluid.

## Cooling Coil Drain Pan and Drain System

The drain pan, trap, and drain pipe must be cleaned regularly to avoid blockage that can reduce or stop water flow as follows:

1. At the beginning of the cooling season, inspect and clean the entire cooling coil cabinet and condensate drain pan to remove contaminants.
2. Inspect and clean the condensate drain trap and piping. The use of a cleanout opening at the top of the trap can help facilitate this maintenance.
3. Fill the trap with water to ensure proper operation and replace the cap on the cleanout opening to close the system.
4. During the end of cooling season shutdown of the system, disconnect and remove all water from the trap and drain to prevent freeze damage. If local building codes permit, the trap may be filled with an antifreeze solution.
5. If the unit is used year round, regularly inspect and clean the cooling coil cabinet, condensate drain pan, and trap/drain system to ensure proper function.
6. Depending on climate, freeze protection of the trap may be required during non-cooling days.

## Duct Furnace

When providing annual maintenance for the duct furnace, keep the unit free from dust, dirt, grease and foreign matter. Pay particular attention to:

1. The power exhauster discharge opening and the combustion air inlet louvers.
2. The burner ports and pilot burner orifices (avoid the use of hard, sharp instruments capable of damaging surfaces for cleaning these ports). To check the burner port and pilot burner orifice, see Burner and Pilot Assembly Removal.
3. The air shutters and main burner orifices (avoid the use of hard, sharp instruments capable of damaging surfaces for cleaning these orifices). To check the air shutters and main burner orifices, see for Manifold Assembly Removal.

The heat exchanger should be checked annually for cracks and discoloration of the tubes. If a crack is detected, the heat exchanger should be replaced before the unit is put back into service. If the tubes are dark gray, airflow across the heat exchanger should be checked to insure that a blockage has not occurred or the blower is operating properly.

## Gas Piping & Controls

The gas valves and piping should be checked annually for general cleanliness and tightness.

The gas controls should be checked to insure that the unit is operating properly.

(continued next page)

	<b>SHOP DRAWING REVIEW</b> PER M/E SPECIFICATIONS SECTIONS
DATE <b>2026/04/29</b>	PROJECT No. <b>24333-08</b>
<input type="checkbox"/> NOT REVIEWED	<input checked="" type="checkbox"/> REVIEWED
<input type="checkbox"/> RESUBMIT	<input type="checkbox"/> REVIEWED AS MODIFIED
<input type="checkbox"/> NOT SPECIFIED BY MCW, REVIEWED FOR MEP ONLY	
ELECTRICAL REVIEWER: <u>R.A.</u>	MECHANICAL REVIEWER: <u>TT</u>

# MAINTENANCE

## Manifold Assembly Removal

To remove the manifold (Refer to Figure 56.1):

1. Shut off gas and electric supply.
2. Remove the side access panel.
3. Disconnect gas manifold at ground union joint.
4. Remove the two screws holding the manifold to the heat exchanger support.
5. Slide the manifold through the manifold bracket.
6. Clean the orifices and adjust the air shutters as necessary.
7. Follow steps 3-6 in reverse to install the manifold assembly.
8. Turn on the electric and gas supply.
9. Check the ground union joint for leaks with a soap solution. Tighten if necessary.
10. Install the side access panel.

**Figure 56.1 - Manifold Assembly Removal**

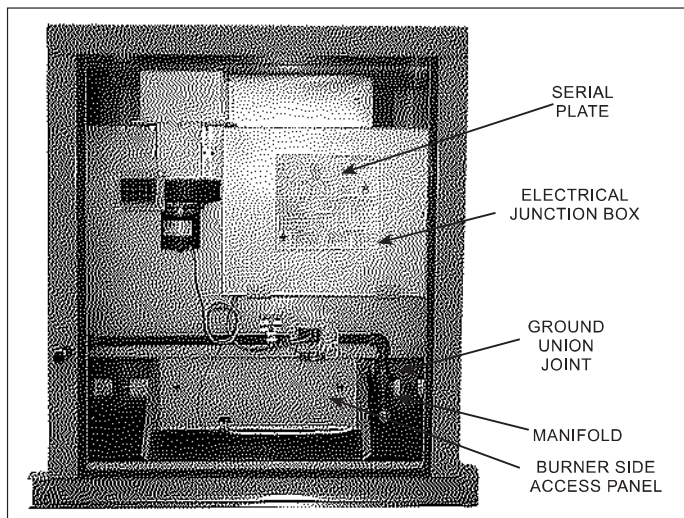

## Burner and Pilot Assembly Removal

To remove the burner (Refer to Figure 56.2):

1. Shut off gas and electric supply.
2. Disconnect the pilot supply line from the gas valve.
3. Disconnect the ignition cable from the ignition controller (located in the electrical junction box). Feed the cable through the bushing in the bottom of the junction box.
4. Remove the screws holding the burner side access panel. Attached to the panel are the burner retaining pins that align the burner.
5. Slide the burner assembly out. The pilot is attached to the burner assembly.
6. Examine the burner and pilot assembly for cleanliness and/or obstructions as necessary (see Duct Furnace for cleaning instructions).
7. Replace the burner assembly in reverse order. In replacing the burner, be certain that the rear burner slots are located properly on the burner retaining pins. Do not force the burner side access panel, it will not fit if the burner is not properly aligned.
8. Reconnect the ignition cable and pilot gas supply line.
9. Turn on the electric and gas supply.

**Figure 56.2 - Burner and Pilot Assembly Removal**

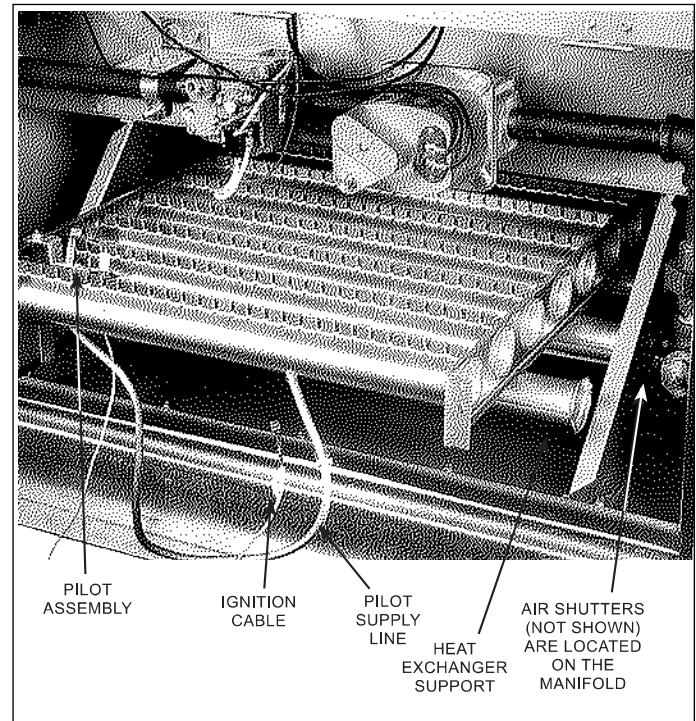

	<b>SHOP DRAWING REVIEW</b>	
	PER M/E SPECIFICATIONS SECTIONS	
DATE	PROJECT No.	
<b>2026/04/29</b>	<b>24333-08</b>	
<input type="checkbox"/> NOT REVIEWED	<input checked="" type="checkbox"/> REVIEWED	
<input type="checkbox"/> RESUBMIT	<input type="checkbox"/> REVIEWED AS MODIFIED	
<input type="checkbox"/> NOT SPECIFIED BY MCW, REVIEWED FOR MEP ONLY		
ELECTRICAL REVIEWER:	MECHANICAL REVIEWER:	
<u>R.A.</u>	<u>TT</u>	

**THIS PAGE INTENTIONALLY LEFT BLANK**

# SERVICE & TROUBLESHOOTING

## ⚠ WARNING

When servicing or repairing this equipment, use only factory-approved service replacement parts. A complete replacement parts list may be obtained by contacting Modine Manufacturing Company. Refer to the rating plate on the unit for complete unit model number, serial number, and company address. Any substitution of parts or controls not approved by the factory will be at the owner's risk

## ⚠ AVERTISSEMENT

Pour l'entretien et les réparations de cet appareil, utilisez uniquement des pièces d'origine certifiées. Pour la liste complète des pièces de rechange, consultez Modine Manufacturing Company. Le numéro de modèle complet, le numéro de série et l'adresse du fabricant figurent sur la plaque signalétique fixée à l'appareil. Toute substitution de pièce ou de commande non approuvée par le fabricant sera aux risques du propriétaire.

## ⚠ CAUTION

Do not attempt to reuse any mechanical or electrical component which has been wet. Such component must be replaced.

## ⚠ ATTENTION

Ne tentez pas de réutiliser un composant mécanique ou électrique qui a été mouillé. Ces composants doivent être remplacés.

## IMPORTANT

To check most of the Possible Remedies in the troubleshooting guide listed in Table 58.1, refer to the applicable sections of the manual.

## IMPORTANT

Pour essayer la plupart des solutions possibles suggérées dans le guide de dépannage du Tableau 58.1 reportez-vous aux sections correspondantes du manuel.

Table 58.1 - Troubleshooting

Trouble	Possible Cause	Possible Remedy
Pilot does not light	1. Main gas is off.	1. Open manual gas valve.
	2. Power supply is off.	2. Turn on main power.
	3. Air in gas line.	3. Purge gas line.
	4. Dirt in pilot orifice.	4. Check for plugged pilot orifice and clean with compressed air if necessary.
	5. Gas pressure out of proper range.	5. Adjust to a minimum for Natural Gas - 6" W.C. Minimum for Propane Gas - 11" W.C. Maximum 14" W.C.
	6. Pilot valve does not open.	6. Check wiring for 24 volts to valve.
	a. Defective ignition controller.	a. Replace ignition controller.
	b. Defective gas valve.	b. Replace gas valve.
7. No Spark at ignitor.	7	7
	a. Loose wire connections.	a. Check all ignition controller wiring.
	b. Pilot sensor is grounded.	b. Replace sensor if cracked or worn
	c. Defective ignition controller.	c. Replace ignition controller.
8. Safety device has cut power.	8.	8. Check all safety devices (High limit, air flow proving switch, power exhauster centrifugal switch, gas pressure switches, etc.) Determine and correct problem. Reset if necessary.
Main burners do not light (Pilot is lit)	1. Defective valve.	1. Replace valve.
	2. Loose wiring.	2. Check wiring to gas valve.
	3. Defective pilot sensor	3. Replace pilot sensor.
	4. Defective ignition controller.	4. Replace ignition controller.
	5. Improper thermostat wiring.	5. Verify wiring compared to wiring diagram.
Lifting Flames (See Figure 59.1)	1. Too much primary air.	1. Reduce primary air.
	2. Main pressure set too high.	2. Adjust to a maximum of 14" W.C.
	3. Orifice too large.	3. Check orifice size with those listed on the serial plate
Yellow Tipping (With propane gas, some yellow tipping is always present.)	1. Insufficient primary air.	1. Increase primary air.
	2. Dirty orifice.	2. Check orifices and clean with compressed air if necessary.
	3. Misaligned orifice.	3. Check manifold, replace if necessary.
Flashback	1. Too much primary air.	1. Reduce primary air.
	2. Main pressure set too high.	2. Adjust to a maximum of 14" W.C.
	3. Orifice too large.	3. Check orifice size with those listed on the serial plate

DRAWING REVIEW

PER M/E SPECIFICATIONS SECTIONS

PROJECT No. 24333-08

DATE 2026/04/29

ELECTRICAL REVIEWER: R.A.      MECHANICAL REVIEWER: TT

NOT REVIEWED       REVIEWED  
 RESUBMIT       REVIEWED AS MODIFIED  
 NOT SPECIFIED BY MEW, REVIEWED FOR MEP ONLY

(Continued next page)

# SERVICE & TROUBLESHOOTING (CONTINUED)

## Troubleshooting (Continued)

Trouble	Possible Cause	Possible Remedy
<b>Floating Flames (See Figure 59.2)</b>	1. Insufficient primary air.	1. Increase primary air.
	2. Main pressure set too high.	2. Adjust to a maximum of 14" W.C.
	3. Orifice too large.	3. Check orifice size with those listed on the serial plate.
	4. Blocked vent cap.	4. Clean louvers in vent cap.
<b>Flame Rollout (See Figure 59.3)</b>	1. Main pressure set too high.	1. Adjust to a maximum of 14" W.C.
	2. Orifice too large.	2. Check orifice size with those listed on the serial plate.
	3. Blocked vent cap.	3. Clean louvers in vent cap.
<b>Not Enough Heat</b>	1. Unit cycling on high limit. ①	1.
	a. Obstructions/leaks in duct system.	a. Clean/correct duct system.
	b. Main pressure set too high.	b. Adjust to a maximum of 14" W.C.
	c. Blower motor not energized.	c. Check that blower motor operates within 45 seconds of when gas controls are energized.
	d. Loose belt	d. Adjust belt tension.
	e. Blower speed too low.	e. Check/correct blower drive settings for proper rpm.
	f. Blocked/damaged venting system.	f. Check/correct venting system.
	g. Defective high limit switch.	g. Replace high limit switch.
	2. Main pressure set too low.	2. Adjust main gas pressure. (Minimum for Natural Gas — 6" W.C. Minimum for Propane Gas — 11" W.C.)
	3. Too much outside air.	3. Adjust outside air damper to decrease outside air percentage (if possible).
	4. Thermostat malfunction.	4. Check/replace thermostat.
	5. Gas controls wired incorrectly.	5. Check unit wiring against the wiring diagram.
	6. Unit undersized.	6. Check design conditions. If unit is undersized, an additional unit(s) or other heat source must be added.
<b>Too Much Heat</b>	1. Thermostat malfunction.	1. Check/replace thermostat.
	2. Gas controls do not shut-off.	2.
	a. Gas controls wired incorrectly.	a. Check unit wiring against the wiring diagram.
	b. Short circuit.	b. Check for loose or worn wires.
	3. Main gas pressure set too high.	3. Adjust to a maximum of 14" W.C.
<b>Power Exhauster Motor Will Not Start</b>	4. Defective gas valve.	4. Replace gas valve.
	1. Power supply is off.	1. Turn on main power.
	2. No 24V power to thermostat.	2. Check control transformer.
	3. Thermostat malfunction.	3. Check/replace thermostat.
	4. Defective power exhauster relay.	4. Replace power exhauster relay.
	5. Defective power exhauster motor.	5. Replace power exhauster motor.

① The duct furnace comes standard with an automatic reset high limit switch that will shut-off the gas should the discharge air temperature become excessive. See Figure 29.1, indicator (49) for the location of the high limit switch. The switch should operate only when something is wrong with the unit operation. Anytime the switch operates, correct the difficulty immediately or serious damage to the switch cuts off the gas supply during normal operation, refer to the "Not Enough Heat" section of Table 58.1.

**Figure 59.1 - Lifting Flame Condition**

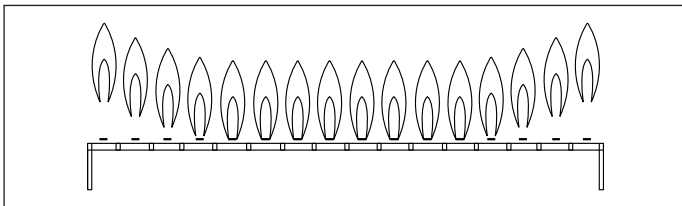

**Figure 59.2 - Floating Flame Condition**

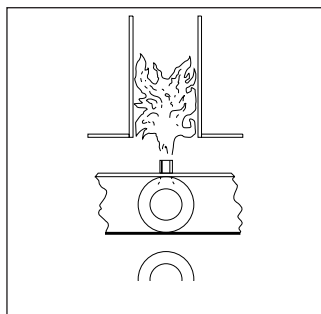

STOP DRAWING REVIEW

PER M/E SPECIFICATIONS SECTIONS

DATE: **2026/04/29** PROJECT No.: **24333-08**

NOT REVIEWED                       REVIEWED  
 RESUBMIT                               REVIEWED AS MODIFIED  
 NOT SPECIFIED BY MCW, REVIEWED FOR MEP ONLY

ELECTRICAL REVIEWER: R.A.                      MECHANICAL REVIEWER: TT

**Figure 59.3 - Flame Rollout Appearance**

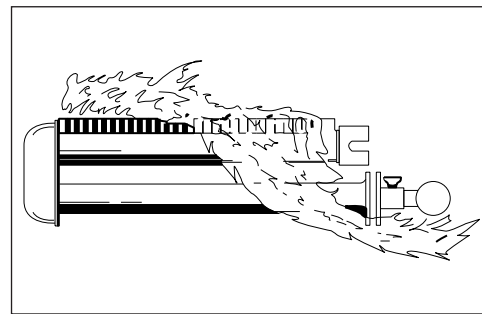

# START-UP CHECKLIST

## Start-Up Checklist

### Indirect Gas-Fired Heating Equipment

Job Name: _____	Date: _____
Address: _____	Model No.: _____
City & State: _____	Order No.: _____
Start-Up Check List "ALL ITEMS MUST BE CHECKED"	Serial No.: _____

1. All shipping straps, braces, tie downs removed?	___ Yes	___ No	
2. Unit installed level and secure?	___ Yes	___ No	
3. Gas burner properly located and aligned?	___ Yes	___ No	
4. Blower and motor alignment okay?	___ Yes	___ No	
5. Bearings aligned and tight on shaft/bearing supports?	___ Yes	___ No	
6. Electrical connections checked and secure?	___ Yes	___ No	
7. Gas piping checked and tightened if necessary?	___ Yes	___ No	
8. Any visible damage to unit?	___ Yes	___ No	
Describe: _____			
If damaged, was the damage repaired?	___ Yes	___ No	
9. Air inlet and discharge checked for obstructions?	___ Yes	___ No	
10. Bearings checked for proper lubrication?	___ Yes	___ No	
11. Filters in place and correct to direction of air flow?	___ Yes	___ No	
12. Belt tension checked?	___ Yes	___ No	
13. Electric supply to unit: _____ Volts, _____ Hz, _____ Phase			
14. Gas supply to unit: _____ Natural, _____ Propane			
15. Gas supply pressure to unit: _____ " W.C., _____ PSIG			
16. Inlet and/or discharge dampers operating correctly?	___ Yes	___ No	
17. Blower rotation correct?	___ Yes	___ No	
18. Blower speed: Hi Speed _____ RPM, Lo Speed _____ RPM			
19. Motor speed: Hi Speed _____ RPM, Lo Speed _____ RPM			
20. Is unit noisy? Excessive vibration?	___ Yes	___ No	
21. Motor voltage: L1 _____ V, L2 _____ V, L3 _____ V			
22. Motor amps: L1 _____ Amp, L2 _____ Amp, L3 _____ Amp			
23. High temperature limit control continuity checked?	___ Yes	___ No	
24. Burner light off			
Low Fire: Does entire burner light off?	___ Yes	___ No	
Hi Fire: Burner pressure reading? _____ " W.C.			
Is flame clean and stable?	___ Yes	___ No	
Does flame modulate in response to temperature control(s)?	___ Yes	___ No	
25. Gas input checked?	___ Yes	___ No	
Input at maximum firing rate: _____ Btu/Hr			
Input at minimum firing rate: - _____ Btu/Hr			
26. Gas piping checked for and free of leaks?	___ Yes	___ No	
27. Has wiring been verified to match the unit wiring diagram?	___ Yes	___ No	
28. Have all the modes of the sequence of operation been verified and tested?	___ Yes	___ No	
29. What optional and/or accessory control device _____ been set _____			
Device: _____ Setting: _____ (_____/psi/Inches W.C./etc.)	___ Yes	___ No	
Device: _____ Setting: _____ (_____/psi/Inches W.C./etc.)	___ Yes	___ No	
Device: _____ Setting: _____ (_____/psi/Inches W.C./etc.)	___ Yes	___ No	

Customer/Owner instructed in operation and maintenance of unit?	___ Yes	___ No	
Name of Person(s) Instructed: _____			
Comments: _____			

Start-Up Company Name: _____	Phone: _____
Signature: _____	Date: _____

SHOP DRAWING REVIEW  
 PER M.E. SPECIFICATIONS SECTIONS  
 PROJECT No. **24333-08**  
 DATE **2026/04/29**

NOT REVIEWED       REVIEWED  
 NOT SPECIFIED BY MCW, REVIEWED FOR MEP ONLY

ELECTRICAL REVIEWER: **R.A.**      MECHANICAL REVIEWER: **TT**

# MODEL DESIGNATIONS

## Model Identification

Modine weatherproof duct furnace/make-up air units contain an ETL/ETL Canada certified weatherproof duct furnace. This duct furnace is combined with either a blower section, or a blower and/or cooling and/or downturn sections to make a complete make-up air or heating/ventilating/cooling unit that is ETL/ETL Canada certified. For this reason, two identification plates are used on these models. The Serial Plate is used to identify the duct furnace and its components. The Model Identification Plate is used to identify the complete model, including blower, cooling, and/or downturn sections.

## Replacement Parts Ordering

When servicing, repairing or replacing parts on these units, locate the model identification plate of the unit and always give the complete Model Number and Serial Number from the model identification plate. The model identification plate is located on the blower section electrical compartment door. For a complete description of the model number, see Weatherproof Model Nomenclature on page 62.

Figure 61.1 - Furnace Serial Plate Location

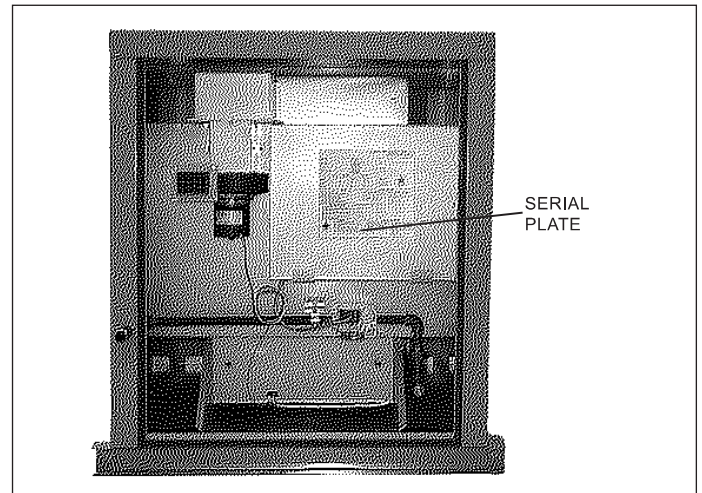

Figure 61.2 - Furnace Serial Plate (sample shown, actual data may vary)

<b>Modine Manufacturing Company</b> 1300 DeKoven Avenue Racine, WI 53403-2532 Phone: 800-828-4328		EXTERIOR GAS-FIRED HEAT EXCHANGER FOR INDUSTRIAL / COMMERCIAL USE CHAUFFAGE A GAZ A COMBUSTION POUR EXTERIEUR / POUR USAGE INDUSTRIEL/COMMERCIAL		Made in U.S.A.		<b>APPROVALS</b> LISTED FOR COMBUSTIBLE SOLID FUEL BURNING APPLIANCE <b>ANSI Z83.8-2013</b> <b>CSA 2.6-2013</b>	
TYPE NUMBER MODEL OF MODEL <b>HFP 75SMRHP40A1</b>		SER. NO. 30000		VOLTS 115		PHASE 1	
SERIAL NUMBER NUMBER OF SERIAL <b>0917093615-003</b>		MIN. HEAT PRESS. FOR PURPOSE OF HEAT EXCHANGER / DIMENSION 11 IN W.C.		HEATS 60		HEATS 1.75	
FUEL OF GAS TYPE OF GAS <b>Propane</b>		MAXIMUM EXHAUST STATIC PRESSURE PRESSURE STATIQUE EXHAUSTIF MAXIMUM 3 IN W.C.		NEW VENTILATED SPEED CODE <b>422</b>		NEW VENTILATED SPEED CODE <b>422</b>	
TEMPERATURE RISE RANGE TEMPERATURE DE HAUTEUR <b>20-100 °F</b>		GAS CONSUMPTION 2000 TO 4000 BTU 67500 BTU		NEW VENTILATED (LISTED MODEL)		SERIAL #1 1. FOR SERVICE INSTALLATIONS ONLY. 2. MECHANICAL WORKING REQUIREMENTS - SEE P. 1. 3. FOR INSTALLATION REQUIREMENTS OF REFRIGERATION SYSTEMS. 4. EXHAUST ON THE OUTSIDE THROUGH THE SIDE OF ANY OPERATING PANEL. 5. FOR OILS: OILS SHOULD BE KEPT AWAY FROM SYSTEM, LEAKS SHOULD BE LOCATED BY ELECTRICAL METHOD ONLY. 6. SEE THIS FOR INSTALLATION AND SERVICE MANUAL FOR MORE INFORMATION AND FOR THE LIST OF REVISIONS ABOUT THIS LIST. LIGHTING INSTRUCTIONS: 1. OPEN ALL GAS VALVES. TURN OFF POWER. 2. SET THERMOSTAT TO FURNACE SYSTEM. SERVICE INSTRUCTIONS: 1. TURN OFF POWER & CLOSE ALL GAS VALVES. REFER TO INSTALLATION & SERVICE MANUAL FOR MORE INSTRUCTIONS * FOR OILS WITH 2-STAGE REFRIGERATION, REGULATION, OR ELECTRONIC REGULATING GAS CONTROLS, A FACTORY DEFENSE AND CONTROLS AND NO REFRIGERANT FILLING.	
WEIGHT <b>75000</b>		WEIGHT <b>67500</b>		NEW VENTILATED SPEED CODE <b>422</b>		SERIAL #1 1. FOR SERVICE INSTALLATIONS ONLY. 2. MECHANICAL WORKING REQUIREMENTS - SEE P. 1. 3. FOR INSTALLATION REQUIREMENTS OF REFRIGERATION SYSTEMS. 4. EXHAUST ON THE OUTSIDE THROUGH THE SIDE OF ANY OPERATING PANEL. 5. FOR OILS: OILS SHOULD BE KEPT AWAY FROM SYSTEM, LEAKS SHOULD BE LOCATED BY ELECTRICAL METHOD ONLY. 6. SEE THIS FOR INSTALLATION AND SERVICE MANUAL FOR MORE INFORMATION AND FOR THE LIST OF REVISIONS ABOUT THIS LIST. LIGHTING INSTRUCTIONS: 1. OPEN ALL GAS VALVES. TURN OFF POWER. 2. SET THERMOSTAT TO FURNACE SYSTEM. SERVICE INSTRUCTIONS: 1. TURN OFF POWER & CLOSE ALL GAS VALVES. REFER TO INSTALLATION & SERVICE MANUAL FOR MORE INSTRUCTIONS * FOR OILS WITH 2-STAGE REFRIGERATION, REGULATION, OR ELECTRONIC REGULATING GAS CONTROLS, A FACTORY DEFENSE AND CONTROLS AND NO REFRIGERANT FILLING.	
HEIGHT <b>60750</b>		HEIGHT <b>54675</b>		NEW VENTILATED SPEED CODE <b>422</b>		SERIAL #1 1. FOR SERVICE INSTALLATIONS ONLY. 2. MECHANICAL WORKING REQUIREMENTS - SEE P. 1. 3. FOR INSTALLATION REQUIREMENTS OF REFRIGERATION SYSTEMS. 4. EXHAUST ON THE OUTSIDE THROUGH THE SIDE OF ANY OPERATING PANEL. 5. FOR OILS: OILS SHOULD BE KEPT AWAY FROM SYSTEM, LEAKS SHOULD BE LOCATED BY ELECTRICAL METHOD ONLY. 6. SEE THIS FOR INSTALLATION AND SERVICE MANUAL FOR MORE INFORMATION AND FOR THE LIST OF REVISIONS ABOUT THIS LIST. LIGHTING INSTRUCTIONS: 1. OPEN ALL GAS VALVES. TURN OFF POWER. 2. SET THERMOSTAT TO FURNACE SYSTEM. SERVICE INSTRUCTIONS: 1. TURN OFF POWER & CLOSE ALL GAS VALVES. REFER TO INSTALLATION & SERVICE MANUAL FOR MORE INSTRUCTIONS * FOR OILS WITH 2-STAGE REFRIGERATION, REGULATION, OR ELECTRONIC REGULATING GAS CONTROLS, A FACTORY DEFENSE AND CONTROLS AND NO REFRIGERANT FILLING.	
WIDTH <b>17500</b>		WIDTH <b>15825</b>		NEW VENTILATED SPEED CODE <b>422</b>		SERIAL #1 1. FOR SERVICE INSTALLATIONS ONLY. 2. MECHANICAL WORKING REQUIREMENTS - SEE P. 1. 3. FOR INSTALLATION REQUIREMENTS OF REFRIGERATION SYSTEMS. 4. EXHAUST ON THE OUTSIDE THROUGH THE SIDE OF ANY OPERATING PANEL. 5. FOR OILS: OILS SHOULD BE KEPT AWAY FROM SYSTEM, LEAKS SHOULD BE LOCATED BY ELECTRICAL METHOD ONLY. 6. SEE THIS FOR INSTALLATION AND SERVICE MANUAL FOR MORE INFORMATION AND FOR THE LIST OF REVISIONS ABOUT THIS LIST. LIGHTING INSTRUCTIONS: 1. OPEN ALL GAS VALVES. TURN OFF POWER. 2. SET THERMOSTAT TO FURNACE SYSTEM. SERVICE INSTRUCTIONS: 1. TURN OFF POWER & CLOSE ALL GAS VALVES. REFER TO INSTALLATION & SERVICE MANUAL FOR MORE INSTRUCTIONS * FOR OILS WITH 2-STAGE REFRIGERATION, REGULATION, OR ELECTRONIC REGULATING GAS CONTROLS, A FACTORY DEFENSE AND CONTROLS AND NO REFRIGERANT FILLING.	
DEPTH <b>37</b>		DEPTH <b>37</b>		NEW VENTILATED SPEED CODE <b>422</b>		SERIAL #1 1. FOR SERVICE INSTALLATIONS ONLY. 2. MECHANICAL WORKING REQUIREMENTS - SEE P. 1. 3. FOR INSTALLATION REQUIREMENTS OF REFRIGERATION SYSTEMS. 4. EXHAUST ON THE OUTSIDE THROUGH THE SIDE OF ANY OPERATING PANEL. 5. FOR OILS: OILS SHOULD BE KEPT AWAY FROM SYSTEM, LEAKS SHOULD BE LOCATED BY ELECTRICAL METHOD ONLY. 6. SEE THIS FOR INSTALLATION AND SERVICE MANUAL FOR MORE INFORMATION AND FOR THE LIST OF REVISIONS ABOUT THIS LIST. LIGHTING INSTRUCTIONS: 1. OPEN ALL GAS VALVES. TURN OFF POWER. 2. SET THERMOSTAT TO FURNACE SYSTEM. SERVICE INSTRUCTIONS: 1. TURN OFF POWER & CLOSE ALL GAS VALVES. REFER TO INSTALLATION & SERVICE MANUAL FOR MORE INSTRUCTIONS * FOR OILS WITH 2-STAGE REFRIGERATION, REGULATION, OR ELECTRONIC REGULATING GAS CONTROLS, A FACTORY DEFENSE AND CONTROLS AND NO REFRIGERANT FILLING.	
APPROVALS ETL Intertek LISTED FOR COMBUSTIBLE SOLID FUEL BURNING APPLIANCE <b>ANSI Z83.8-2013</b> <b>CSA 2.6-2013</b>		APPROVALS ETL Intertek LISTED FOR COMBUSTIBLE SOLID FUEL BURNING APPLIANCE <b>ANSI Z83.8-2013</b> <b>CSA 2.6-2013</b>		APPROVALS ETL Intertek LISTED FOR COMBUSTIBLE SOLID FUEL BURNING APPLIANCE <b>ANSI Z83.8-2013</b> <b>CSA 2.6-2013</b>		APPROVALS ETL Intertek LISTED FOR COMBUSTIBLE SOLID FUEL BURNING APPLIANCE <b>ANSI Z83.8-2013</b> <b>CSA 2.6-2013</b>	

Figure 61.3 - Model Identification Plate (sample shown, actual data may vary)

<b>MODEL IDENTIFICATION PLATE</b>				<b>MODEL NUMBER</b> <b>HBP400TMLN90F3JI6LDA00</b>			
VOLTAGE <b>460V3~</b>		HERTZ <b>60</b>		PHASE <b>3</b>		SERIAL NUMBER <b>15100905051234-1111</b>	
KW <b>12.1</b>		KW (TYP) <b>5.59 (7.5)</b>		ORDER <b>99999999</b>		SPO <b>12345678</b>	
SUPPLY VOLTAGE <b>460V3~</b>		HERTZ <b>12</b>		PHASE <b>1</b>		SHORT CIRCUIT CURRENT: 5KA RMS SYMMETRICAL, 460V MAXIMUM Refrigerant: R410a	
FLA <b>12.1</b>		MCA <b>14.8</b>		MOP (TIME DELAY) <b>25</b>		SERIAL #1 1. FOR SERVICE INSTALLATIONS ONLY. 2. MECHANICAL WORKING REQUIREMENTS - SEE P. 1. 3. FOR INSTALLATION REQUIREMENTS OF REFRIGERATION SYSTEMS. 4. EXHAUST ON THE OUTSIDE THROUGH THE SIDE OF ANY OPERATING PANEL. 5. FOR OILS: OILS SHOULD BE KEPT AWAY FROM SYSTEM, LEAKS SHOULD BE LOCATED BY ELECTRICAL METHOD ONLY. 6. SEE THIS FOR INSTALLATION AND SERVICE MANUAL FOR MORE INFORMATION AND FOR THE LIST OF REVISIONS ABOUT THIS LIST. LIGHTING INSTRUCTIONS: 1. OPEN ALL GAS VALVES. TURN OFF POWER. 2. SET THERMOSTAT TO FURNACE SYSTEM. SERVICE INSTRUCTIONS: 1. TURN OFF POWER & CLOSE ALL GAS VALVES. REFER TO INSTALLATION & SERVICE MANUAL FOR MORE INSTRUCTIONS * FOR OILS WITH 2-STAGE REFRIGERATION, REGULATION, OR ELECTRONIC REGULATING GAS CONTROLS, A FACTORY DEFENSE AND CONTROLS AND NO REFRIGERANT FILLING.	

**SHOP DRAWING REVIEW**  
PER M/E SPECIFICATIONS SECTIONS

DATE: **2026/04/29**

PROJECT No. **24333-08**

NOT REVIEWED                       REVIEWED  
 RESUBMIT                               REVIEWED AS MODIFIED  
 NOT SPECIFIED BY MCW, REVIEWED FOR MEP ONLY

**ELECTRICAL REVIEWER: R.A.**                      **MECHANICAL REVIEWER: TT**

# MODEL NOMENCLATURE FOR SYSTEM UNITS

## Weatherproof Model Nomenclature

1	2	3	4 5 6	7	8	9	10	11	12	13	14	15	16	17	18	19	20 21	22	23
PT	UC	V	MBH	HE	DS	AS	ATR	GT	GV	SS	SV	TR	BB	HP	MT	SA	AC	EC	CC

### 1 - Product Type (PT)

H or O - Outdoor HVAC Unit

### 2 - Unit Configuration (UC)

B - Blower Package - Furnace & Blower  
 C - Cooling Package - Furnace, Blower, & Cooling Cabinet  
 D - Downturn Package - Furnace, Blower, & Downturn  
 P - Packaged Unit - Furnace, Blower, Cooling Cabinet, & Downturn

### 3 - Venting (V)

P - Power

### 4,5,6 - Furnace Input Rating (MBH) (Except for 840 & 960)

100 - 100,000 Btu/Hr Input	350 - 350,000 Btu/hr Input
125 - 125,000 Btu/Hr Input	400 - 400,000 Btu/Hr Input
150 - 150,000 Btu/Hr Input	500 - 500,000 Btu/Hr Input
175 - 175,000 Btu/Hr Input	600 - 600,000 Btu/Hr Input
200 - 200,000 Btu/Hr Input	700 - 700,000 Btu/Hr Input
225 - 225,000 Btu/Hr Input	800 - 800,000 Btu/Hr Input
250 - 250,000 Btu/Hr Input	840 - 1,050,000 Btu/Hr Input
300 - 300,000 Btu/hr Input	960 - 1,200,000 Btu/Hr Input

### 7 - Heat Exchanger/Burner/Drip Pan Material (HE)

T - 409 Stainless Steel Heat Exchanger/Burner/Drip Pan

### 8 - Development Sequence Designation (DS)

F - Single Stage  
 M - 2-stage or Modulating

### 9 - Access Side (AS)

R - Right Hand  
 L - Left hand

### 10 - Air Temperature Rise (ATR)

H - High 60°-100°F  
 L - Low 20°-60°F

### 11 - Gas Type (GT)

N - Natural with ignition controller  
 P - Propane with ignition controller

### 12 - Gas Valve (GV)

1 - Single Stage  
 2 - Two Stage  
 4 - Electronic Modulation  
 7 - Electronic Modulation 0-10 Vdc External Input  
 9 - Electronic Modulation with Modine Control System

### 13 - Additional Safety Switches (SS)

0 - No Switches (Standard)  
 3 - High and Low Gas Pressure Switch (Premium)

### 14 - Supply Voltage (SV)

A - 115/60/1	E - 230/60/3
B - 208/60/1	F - 460/60/3
C - 230/60/1	G - 575/60/3
D - 208/60/3	

### 15 - Transformer (TR)

1 - 40 VA	4 - 250 VA
2 - 75 VA	0 - None
3 - 150 VA	

### 16 - Blower Size & Bearing Type (BB)

C - 9-9 Spider Bearings	H - 15-15 Pillow Block Bearings
D - 9-9 Pillow Block Bearings	I - 18-18 Spider Bearings under 15 Hp
E - 12-12 Spider Bearings	J - 18-18 Pillow Block Brngs under 15 Hp
F - 12-12 Pillow Block Brngs	K - 18-18 Pillow Block Brngs, 15 Hp & Up
G - 15-15 Spider Bearings	L - 20-18 Pillow Block Bearings

### 17 - Motor Horsepower (HP)

A - 1/3 Hp	L - 1/3 Hp with Motor Starter
B - 1/2 Hp	M - 1/2 Hp with Motor Starter
C - 3/4 Hp	N - 3/4 Hp with Motor Starter
D - 1 Hp	P - 1 Hp with Motor Starter
E - 1-1/2 Hp	Q - 1-1/2 Hp with Motor Starter
F - 2 Hp	R - 2 Hp Hp with Motor Starter
G - 3 Hp	S - 3 Hp with Motor Starter
H - 5 Hp	T - 5 Hp with Motor Starter
I - 7-1/2 Hp	W - 7-1/2 Hp with Motor Starter
J - 10 Hp	X - 10 Hp with Motor Starter
K - 15 Hp	Y - 15 Hp with Motor Starter
V - 20 Hp	Z - 20 Hp with Motor Starter

### 18 - Motor Type (MT)

1 - ODP  
 2 - ODP - High Eff.  
 5 - TE  
 6 - TE - High Eff.

### 19 - Sheave Arrangement (SA)

A-Z - (See Sheave Tables)

### 20,21 - Air Control (AC)

AA - RA Opening  
 BA - FA Opening  
 CA - FA & RA Openings  
 DA - FA Dampers w/ 2 pos motor (No RA)  
 EA - FA & RA Dampers w/ 2 pos motor  
 GA - FA & RA Mod motor w/ 0-10 Vdc External Input  
 GC - FA & RA Mod motor w/ Minimum Position (Factory Mounted)  
 GE - FA & RA Mod motor w/ 3 pos. damper (100% RA, Variable, 100% OA)

### 22 - Evaporative Cooling (EC)

0 - None  
 D - 12" GLASdek Media, Stainless Steel Casing

### 23 - Cooling Coil (CC)

0 - None  
 1 - Factory Installed P410A Coil  
 2 - Factory Installed P32 Coil  
 3 - Factory Installed P454B Coil

SHOP DRAWING REVIEW

PER M/E SPECIFICATIONS SECTIONS

DATE: 2026/04/29

PROJECT No. 24333-08

<input type="checkbox"/> NOT REVIEWED	<input checked="" type="checkbox"/> REVIEWED
<input type="checkbox"/> RESUBMIT	<input type="checkbox"/> REVIEWED AS MODIFIED
<input type="checkbox"/> NOT SPECIFIED BY MCW, REVIEWED FOR MEP ONLY	
ELECTRICAL REVIEWER: <u>R.A.</u>	MECHANICAL REVIEWER: <u>TT</u>

# WARRANTY

This Warranty (the "Warranty") shall apply to Products (as defined below) sold by Modine Manufacturing Company, a Wisconsin corporation ("Seller") to you ("Buyer").

Seller hereby warrants that during the Applicable Warranty Period (as defined below) its Products shall be free from defects in material and factory workmanship under normal use and service, subject to the EXCLUSIONS described below and according to the terms outlined in this Warranty.

If Seller receives written notice of a breach of this Warranty prior to the end of the Applicable Warranty Period (which such notice shall include the model and serial numbers of the Product, as well as the date and a reasonably detailed description of the Product's alleged failure), Buyer shall with Seller's prior written approval, return the applicable Product or component thereof to Seller with shipping charges prepaid; if upon examination by Seller such Product or component thereof is disclosed to have been defective, then Seller will, without charge to Buyer, at Seller's option, either repair the Product, replace defective parts in the Product, or offer an entire replacement unit of the Product; provided that the warranty period for a Product that has been repaired or provided with replacement parts shall not extend beyond the original Applicable Warranty Period, nor shall any replacement parts provided for a Product be under any warranty beyond the original Applicable Warranty Period for the Product; similarly, if Seller provides an entire replacement unit of the Product, the warranty period for the replacement unit is limited to the remainder of the original Applicable Warranty Period. Seller shall have no responsibility for installation, service, field labor, shipping, handling, or other costs or charges, except as expressly provided in this Warranty. Buyer shall have no remedy hereunder for any defective part returned without proper written authorization from Seller, as described above.

For purposes of this Warranty and subject to the exclusions described below, the term "Products" shall mean parts or equipment manufactured by Seller, sold to Buyer pursuant to a purchase contract between Buyer and Seller (most often initiated by a purchase order issued by Buyer and accepted by Seller), and expressly described in such contract. The term "Products" shall not include third-party parts or equipment furnished by Seller, except that, to the extent assignable, Seller will assign to Buyer the benefits (together with all limitations and exclusions) of the third-party manufacturer's warranty for such parts or equipment. This Warranty extends only to the original purchase contract between Buyer and Seller and is nontransferable, except that this Warranty may be assigned to an Authorized End User (as defined below). All replaced parts or equipment shall become Seller's property. For purposes of this Warranty, the term "Applicable Warranty Period" shall mean the warranty period set forth in the table below for each type or class of Product described on the table; provided that, when the Product is to be used as a component part of equipment manufactured by Buyer, the Applicable Warranty Period shall be limited to one (1) year after the date of shipment from Seller, notwithstanding anything in the table below to the contrary. For purposes of this Warranty, the term "Authorized End User" shall mean any third-party that purchases the Product directly or indirectly from Buyer for the Authorized End User's own use upon the first installation of the Product and not for resale.

BUYER HEREBY ACKNOWLEDGES THAT ITS REMEDIES FOR BREACH OF THIS WARRANTY, EXCLUSIVE OF ALL OTHER REMEDIES PROVIDED BY LAW, ARE LIMITED AS DESCRIBED ABOVE.

EXCLUSIONS AND LIMITATIONS: This Warranty is subject to the following exclusions and limitations:

The term "Products" shall not include and this Warranty shall not apply to any of the following items: refrigerant gas, belts, filters, fuses and other items consumed or worn out by normal wear and tear.

In addition, this Warranty shall not apply to:

- (1) Products or components thereof that are damaged or adversely affected by conditions beyond Seller's control, including but not limited to polluted or contaminated or foreign matter contained in the air or water utilized for heat exchanger (condenser) cooling or if the failure of the part is caused by improper air or water supply, or improper or incorrect sizing of power supply;
- (2) Any Products or components thereof which have been repaired or altered outside the factory of Seller in any way, or otherwise subject to unauthorized repairs or alterations, so as, in the judgment of Seller, to affect the Product's durability or performance;
- (3) Materials or labor of any kind not furnished by Seller, or any charges for any such labor or materials, whether such labor, materials or charges thereon are due to replacement of parts, adjustments, repairs, or any other work done by any party other than Seller;
- (4) Labor or other costs incurred for diagnosing, repairing, removing, installing, shipping, servicing, or handling of either defective or replacement parts;
- (5) Any Products removed from their original location for reinstallation in another location;
- (6) Any Products or components thereof which have been operated, maintained, or serviced contrary to Seller's written installation, operation, and/or servicing instructions or owner's manual;
- (7) Damages resulting from operation with an inadequate or interrupted supply of air or water;
- (8) Any Products or components thereof which have been subjected to misuse, negligence, faulty installation, improper servicing, accident, excessive thermal shock, excessive humidity, physical damage, impact, abrasion, improper operation, or other operating conditions in excess of or contrary to those for which such equipment was designed;
- (9) With respect to gas-fired or oil-fired units, any Products or components thereof if the input to the Product exceeds the rated input (as indicated on the Product's serial plate) by more than five percent (5%);
- (10) Any Products or components thereof which have been installed in coastal applications, subjected to corrosive fluids, or damaged or otherwise affected by the effects of the physical or chemical properties of water or steam or other liquids or gases used in the Product or any component thereof;
- (11) Damage or failure to start resulting from improper voltage conditions, blown fuses, open circuit breakers, or other

**MEW** **MECHANICAL DRAWING REVIEW**  
**DATE: 2026/04/29** **PROJECT NO. 24353-08**

NOT REVIEWED       REVIEWED

RESUBMIT       REVIEWED AS MODIFIED

NOT SPECIFIED BY MCW, REVIEWED FOR MEP ONLY

**ELECTRICAL REVIEWER: R.A.**      **MECHANICAL REVIEWER: TT**

inadequacy or interruption of electrical service or fuel supply; or (12) Any Products or components thereof from which the serial number has been altered, defaced or removed.

BUYER AGREES THAT THE WARRANTIES AND REMEDIES DESCRIBED HEREIN ARE THE ONLY WARRANTIES AND REMEDIES PROVIDED BY SELLER WITH RESPECT TO THE PRODUCTS AND TO THE MAXIMUM EXTENT PERMITTED UNDER APPLICABLE LAW SHALL BE IN LIEU OF AND EXCLUSIVE OF ALL OTHER WARRANTIES AND REMEDIES WHATSOEVER, EITHER EXPRESS OR IMPLIED, WHETHER ARISING FROM LAW, COURSE OF DEALING, USAGE OF TRADE, OR OTHERWISE, **INCLUDING BUT NOT LIMITED TO WARRANTIES OF MERCHANTABILITY, FITNESS FOR A PARTICULAR PURPOSE, AND NON-INFRINGEMENT, EACH OF WHICH SELLER HEREBY EXPRESSLY DISCLAIMS.** SELLER NEITHER ASSUMES (NOR HAS AUTHORIZED ANY PERSON TO ASSUME) ANY OTHER WARRANTY OR LIABILITY IN CONNECTION WITH ANY PRODUCTS. REPRESENTATIONS AND CONDITIONS, EXPRESS OR IMPLIED BY STATUTE, TRADE USAGE, OR OTHERWISE, ARE EXCLUDED AND WILL NOT APPLY TO THE PRODUCTS UNDER THIS WARRANTY, EXCEPT FOR WARRANTIES WHICH BY LAW CANNOT BE EXCLUDED

OR LIMITED. Without limiting the foregoing, Seller makes no and specifically disclaims all representations and/or warranties that the Products will detect the presence of, or eliminate, prevent, treat, or mitigate the spread, transmission, or outbreak of any pathogen, disease, virus, or other contagion, including but not limited to COVID 19.

BUYER AGREES THAT IN NO EVENT WILL SELLER BE LIABLE FOR COSTS OF PROCESSING, LOST REVENUES OR PROFITS, INJURY TO GOODWILL, OR ANY OTHER SPECIAL, CONSEQUENTIAL, OR INCIDENTAL DAMAGES OF ANY KIND RESULTING FROM THE PURCHASE OF THE PRODUCTS, OR FROM BUYER'S USE OF ANY PRODUCT, WHETHER ARISING FROM BREACH OF WARRANTY, NONCONFORMITY TO ORDERED SPECIFICATIONS, DELAY IN DELIVERY, OR ANY OTHER LOSS SUSTAINED BY THE BUYER.

**OPTIONAL SUPPLEMENTAL WARRANTY**

Buyer may purchase from Seller a supplemental warranty with respect to Products which shall extend the Applicable Warranty Period as set forth in the express terms and conditions described in the supplemental warranty agreement. Such supplemental warranty terms may include an additional four (4) years on certain compressors, an additional five (5) years "all parts" warranty, an additional four (4) or nine (9) years on certain heat exchangers, and/or such additional supplemental warranty terms as Seller chooses to make available to its customers from time to time.

COMPONENT	APPLICABLE MODELS		APPLICABLE WARRANTY PERIOD (WHICHEVER OCCURS FIRST)	
			Time from Date of First Beneficial Use by Buyer or Authorized End User	Time from Date of Shipment from Seller
Heat Exchangers and/or Coils	Gas Fired Unit Heaters with Tubular Style Heat Exchangers (e.g. HD, HDS, PTX, BTX, etc)	Aluminized or Stainless Steel	10 YEARS	126 MONTHS
	Gas Fired Unit Heaters with Clam-Shell Style Heat Exchangers (e.g. PDP, BDP, etc.)	Aluminized Steel (not in high humidity applications)	10 YEARS (must be Stainless Steel in high-humidity applications)	126 MONTHS
		Aluminized Steel (in high-humidity applications)	1 YEAR	18 MONTHS
		Stainless Steel	10 YEARS	126 MONTHS
	Low Intensity Infrared Units		5 YEARS	66 MONTHS
	Indoor and Outdoor Duct Furnaces and System Units, Steam/Hot Water Units, Oil-Fired Units, Electric Units, Cassettes, Vertical Unit Ventilators, Geothermal Units		1 YEAR	18 MONTHS
Burners and Elements	Low Intensity Infrared Units		2 YEARS	30 MONTHS
	High Intensity Infrared and Electric Infrared Units		1 YEAR	18 MONTHS
Compressors	Condensing Units for Cassettes		5 YEARS	66 MONTHS
	Vertical Unit Ventilators, Geothermal Units		1 YEAR	18 MONTHS
Sheet Metal Parts	All Products		1 YEAR	18 MONTHS
Components, excluding Heat Exchangers, Coils, Condensers, Burners, Sheet Metal	All Products		2 YEARS	30 MONTHS

**SHOP DRAWING REVIEW**  
PER M/E SPECIFICATIONS SECTIONS

DATE: **2026/04/29** PROJECT No.: **24333-08**

NOT REVIEWED       REVIEWED

RESUBMIT       REVIEWED AS MODIFIED

NOT SPECIFIED BY MCW, REVIEWED FOR MEP ONLY

ELECTRICAL REVIEWER: **R.A.**      MECHANICAL REVIEWER: **TT**

As Modine Manufacturing Company has a continuous product improvement program, it reserves the right to change design and specifications without notice.



**Modine Manufacturing Company**  
1800 DeKoven Avenue  
Racine, WI 53403  
Phone: 1.800.828.4328 (HEAT)  
www.modinehvac.com