



# **N-XC65-WP**

## **IP Audio Window Intercom Kit Weather Resistant**



**Bi-directional communication,  
broadcasting intelligible messages**

# N-XC65-WP

## IP Audio Window Intercom Kit Weather Resistant

Suitable for two-way communication for banking counters, airports or information centres, the N-XC65-WP IP Window Intercom System offers a stylish, high performance option when speech is impaired by glass or other obstruction.

Its single digital signal processor multi-channel acoustic technology effectively tunes out interference resulting in high voice intelligibility. The terminal is capable of identifying sound sources at the same time while suppressing environment noise and automatically adjusting sound volume.

- Duplex Class D amplifier
- IP65 rated speaker
- Three possible listening modes (quiet / standard / noisy)
- Professional design with hard meta structure preventing machine resonance
- Speaker and microphone
- IP Control
- Analog output on the interface to record conversation
- Support dual recording mode (analog & digital)

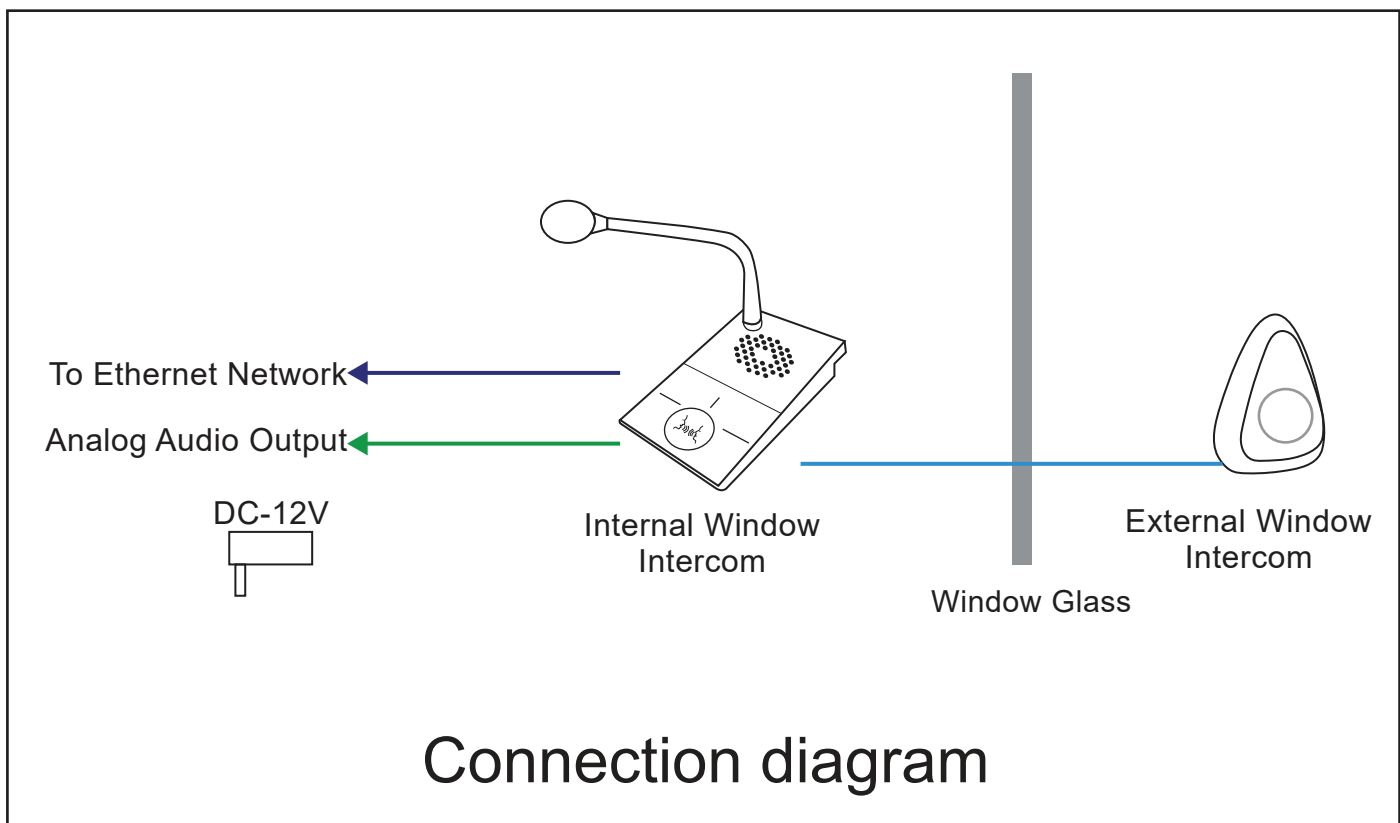

MODEL	N-XC65-WP
Power Supply	DC 12V 1.5A
Consumption	≤ 5W
Network Protocol	TCP/IP, UDP, ARP, ICMP, IGMP, FTP
Audio Code	PCM/AAC
Audio Sampling	8 KHz - 32 KHz
S/N	> 90 dB
Frequency Response	20 Hz - 16 KHz
Interface	1x RJ45, 1x Power Supply port, 1x External Unit, 1x Rec out
Outputs	1 x 600 Ω Unbalanced Line Audio Output
Dust/Water Protection	IP65 (WP version Only)
Working Temperature	-10°C - +55°C
Humidity	≤ 90% RH (Not condensing)
Dimensions	Internal unit 160 x 95 x 46.5mm External unit 83 x 24mm
Weight	Internal Unit 0.44 kg External Unit 0.25 kg



TOA Canada Corporation  
[www.TOAcanda.com](http://www.TOAcanda.com)  
[sales@toacanda.com](mailto:sales@toacanda.com)