



**T26-04 Archbishop Denis O'Connor Catholic High School HVAC Replacement
Addendum No 1**

Closing Date: Thursday, May 14, 2026, 2:00 PM

Addendum Date: Wednesday, April 29, 2026

Issued by: Purchasing Services
Durham Catholic District School Board

This addendum will form a part of the bid documents for the above noted Bid and shall be read in conjunction herewith. This addendum will take precedence over all requirements of the original bid documents and any addenda issued previously.

Bidders shall acknowledge receipt of this addendum with their electronic bid submission on the declaration page in the bidding system.

The HVAC equipment outlined in the Bill of Materials has been pre-purchased by the Durham Catholic District School Board at a fixed cost. Installation of this equipment shall be carried out by the successful mechanical contractor, and the value of the equipment is to be deducted from the Cash Allowance.

Additional information is attached as follows:

1. Letter of Intent and Amendment.
2. HVAC Equipment Bill of Materials
3. HVAC Shop drawings
 - a. 98343-RTU 1_2_3-Shop Drawings_2026-04-01-213748
 - b. 98345-AHU-1_2-Shop Drawings_2026-04-01-220456
 - c. 98346-Air Cooled Condensing Units-Shop Drawings_2026-04-01-221518
 - d. 98430-Energy Recovery Units-Shop Drawings_2026-04-20-100936 – REW
 - e. 98496-RTU-7_8-Shop Drawings_2026-04-07-142647 - REW

[End of Addendum No 1]



**DURHAM CATHOLIC
DISTRICT SCHOOL BOARD**
Learning and Living in Faith

INTENT TO AWARD

March 24, 2026

Via: Email

HTS Engineering Ltd.
115 Norfinch Drive
North York, ON
M3N 1W8

Attention: Terry Loyala

Re: **Intent to Award – Supply and Deliver HVAC Equipment for Project Number T26-04 Archbishop Denis O'Connor Catholic High School**

Owner: Durham Catholic District School Board (“DCDSB” or the “Board”)

Dear Terry,

This Intent to Award confirms that the Owner, DCDSB, intends to purchase packaged HVAC equipment supplied and delivered by HTS Engineering Ltd. (“HTS”) for the above-noted project at the specified price and lead times provided in the quotation/job number 22600705 submitted by HTS dated March 16, 2026, attached as Appendix A to this Letter.

The total value of the equipment packages is [REDACTED] plus HST and includes:

- **Energy Recovery Ventilator (ERV)**
- **Air Handling Unit (AHU)**
- **Rooftop Units (RTUs)**

Limited Warranty

The agreed upon Limited Warranty is twenty-four (24) months. Warranty start date is 6 months from delivery or start up, whichever is the lesser.

Project Procurement

The Durham Catholic District School Board will conduct a competitive bid under Project number T26-04 inviting DCDSB's pre-qualified Mechanical Contractors. The packaged HVAC equipment supplied by HTS will be incorporated into the tender documents as a cash allowance item.

Ownership

Following the tender award, the equipment supplied by HTS will be purchased by the Mechanical Contractor. The mechanical contractor will assume ownership during the construction phase(s) until Substantial Completion at which point the Durham Catholic District School Board will take ownership.

Shop Drawings and Coordination

HTS shall provide equipment in accordance with the approved shop drawings.

HTS will provide the following as part of the equipment supply:

- Equipment shop drawings and submittals
- Product data sheets and technical documentation
- Coordination with the project mechanical contractor for delivery and installation

Shop drawing review and approval will be completed in accordance with the project tender documents and consultant review procedures.

Pricing Validity

HTS agrees that the pricing contained within the final quotation shall remain valid for the duration of the tender period and subsequent award of the project, provided the scope of equipment supply remains consistent with the submitted quotation.

Lead Time Confirmation

HTS confirms that the lead times stated in the submitted quotation are accurate at the time of this Letter.

Sincerely,



Kristy Hottot
Supervisor, Purchasing Services
Durham Catholic District School Board

Acceptance

Please confirm your acknowledgment and agreement of this Intent to Award by signing below.

HTS Engineering Ltd.

Name: Danny Russell
Title: HTS Change Order Manager
Date: Mar 24/26
Signature: 

Attached: Appendix A

cc: Scott Grieve, Superintendent of Business, Finance and Facilities Services, DCDSB
Nick Pare, Energy Management Supervisor, DCDSB
Consultant: John MacQuarrie, Associate Principal, Rybka Ellard Willson



**DURHAM CATHOLIC
DISTRICT SCHOOL BOARD**
Learning and Living in Faith

**INTENT TO AWARD
Amendment No 1**

April 24, 2026

Via: Email

HTS Engineering Ltd.
115 Norfinch Drive
North York, ON
M3N 1W8

Attention: Terry Loyala

Re: **Supply and Deliver HVAC Equipment for Project Number T26-04 Archbishop
Denis O'Connor Catholic High School**

Owner: Durham Catholic District School Board ("DCDSB" or the "Board")

Dear Terry,

This Amendment to the Intent to Award dated March 24, 2026, confirms the pricing and equipment list for the above-noted project have been revised in accordance with HTS quotation/job number 22600705 dated April 1, 2026, attached hereto as Appendix A-1.

The total value of the equipment packages has been revised to [REDACTED] plus HST.

Summary of changes include:

RTU-1: O/A 50% (increased from 20%)
RTU-2: O/A 50% (increased from 20%)
RTU-3: O/A 50% (increased from 20%)
AHU-1: S/A; 29,000 CFM (increased CFM), O/A: 50% (increased from 20%)
AHU-2: S/A: O/A: 40% (increased from 20%)
AHU-3: O/A: 50% (increased from 20%)
ERV-1,2 serve AHU-1,2, and the sizes were increased to suite.
Removed cooling capability on RTU-7,8. These are now heating only RTUs.
Removed RF-1, RF-2 and associated VFDs from the scope.

All remaining terms and conditions contained in the original Intent to Award dated March 24, 2026 remain in full force and effect.

Sincerely,



Kristy Hottot
Supervisor, Purchasing Services
Durham Catholic District School Board

Acceptance

Please confirm your acknowledgment and agreement of this Amendment No 1 by signing below.

HIS Engineering Ltd.

Name: _____

Title: _____

Date: _____

Signature: _____

Attached: Appendix A-1

cc: Scott Grieve, Superintendent of Business, Finance and Facilities Services, DCDSB
Nick Pare, Energy Management Supervisor, DCDSB
John MacQuarrie, Consultant, Associate Principal, Rybka Ellard Willson

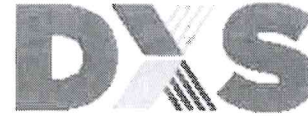

Job	22600705 DCDSB - Archbishop Denis O'Connor	ID# - Title	2 - Owner Direct
		Version	1.2
Designer	ELLARD	Commander	-
Bidder	Durham Catholic District School Board * 650 Rossland Rd W Oshawa ON L1J 7C4 Canada	Rep	Curtis Metrow
		Rep Mobile	705-930-4151
		Rep Email	curtis.metrow@hts.com
Contact	Scott Grieve	Printed	2026-04-22 21:02
Direct	905-576-5776 x2358	Closing	2026-04-01
Mobile	905-442-4970	Specifications dated	-
Email	-	Plans dated	-
		Last addendums	REV 1 Apr1-26

Base Equipment Summary

Tags	Description	Qty	Total Capacity	Spec Level	Lead Time	Section Pricing
AHU-1	DAIKIN: CAH- Indoor Vision Air Handling	1	29,000 CFM		10 - 12 weeks	
CU-1	DAIKIN: Air Cooled Condensing Unit	1	100 tons		16 - 18 weeks	
AHU-2	DAIKIN: CAH- Indoor Vision Air Handling	1	8,500 CFM		10 - 12 weeks	
CU-2	DAIKIN: Air Cooled Condensing Unit	1	25 tons		16 - 18 weeks	
AHU-3 CC	DAIKIN: Cooling Coil	1	11,760 CFM		8 - 10 weeks	
AHU-3 HC	DAIKIN: Heating Coil	1	11,760 CFM		8 - 10 weeks	
CU-3	DAIKIN: Air Cooled Condensing Unit	1	50 tons		16 - 18 weeks	
AHU-4 HC	DAIKIN: Heating Coil	1	2,600 CFM		8 - 10 weeks	
Spec Section , Air Handling Units						A
ODU-1	DAIKIN COMMERCIAL: 10 ton, 230V, VRV EMERION HP	1	0 tons	Basis of Design		
ACC-1	DAIKIN COMMERCIAL: AHU INTEGRATION VALVE KIT - 150 MBH	1	0 Each	Basis of Design		
ACC-2	DAIKIN COMMERCIAL: W-CONTROL BOX (0-10V DDC CONTROL)	1	0 Each	Basis of Design		
AHU-4 CC	CANCOIL: Cooling Coil	1	2,600 CFM		8 - 10 weeks	
Spec Section , Daikin VRV						B
Total					A + B	
RTU-1	DAIKIN: Rebel Rooftop Systems	1	15 tons		16 - 18 weeks	
RTU-2	DAIKIN: Rebel Rooftop Systems	1	16 tons		16 - 18 weeks	
RTU-3	DAIKIN: Rebel Rooftop Systems	1	25 tons		16 - 18 weeks	
RTU-7,8	DAIKIN: Rebel Rooftop Systems	2	CFM		16 - 18 weeks	
Spec Section , Rooftop Units						
ERV-1 (AHU-1)	ALDES: Advanced Series	1	14,500 CFM		16 - 18 weeks	
ERV-2 (AHU-2)	ALDES: Advanced Series	1	4,250 CFM		16 - 18 weeks	
Spec Section , Energy Recovery Ventilators						

Total Bulk Price

Pricing Terms

All Taxes Extra (HST, Tariffs, Duty, etc.)
Freight Allowed to Site
FOB Manufacturer's Factory

22600705 DCDSB - Archbishop Denis O'Connor Owner Direct.
2026-04-22



**BEST
MANAGED
COMPANIES**
Platinum member

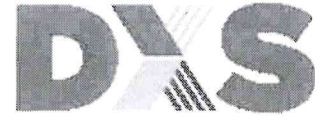

No Holdbacks acceptable

Price is in effect for 15 days from time of quote

Tariff payment terms are COD (i.e. To be paid immediately and prior to equipment delivery)

10% shop drawing invoice of contract value upon shop drawing submission

Base Equipment Details - Owner Direct Scope of Work

Spec Section: -- Air Handling Units

Tags	Description	Qty	Capacity	Lead Time
AHU-1	DAIKIN: CAH- Indoor Vision Air Handling	1	29,000 CFM	10 - 12 weeks

c/w

- Outside casing with G90 galvanized steel panel
- Liner with G90 galvanized solid internal liner
- 6" Base rail
- Insulation material (R-13 injected foam)

Supply Fan Section

- Fan array complete with vfd per fan
- High efficiency motors
- Access door with window
- Marine light with switch (wiring by others)

Cooling Coil Section

- Cooling coil
- Access door
- Stainless steel drain pan

Heating Coil Section

- Heating coil

Filter Section

- 2" Merv 8 filters

Mixing Section

- Low leak, insulated dampers

Not Quoting/Including:

- Starters or disconnects
- Single point power connection
- Site assembly of sections (unit ships in multiple sections)
- Flex duct connection on units with external isolation
- External isolation
- Rigging
- Spare filters
- Balancing sheaves
- Controls unless specifically noted
- External wiring
- Sections/accessories not specifically noted

Tags	Description	Qty	Capacity	Lead Time
CU-1	DAIKIN: Air Cooled Condensing Unit	1	100 tons	16 - 18 weeks

c/w

- High efficiency Copeland® scroll compressors
- All units feature dual refrigeration circuits for redundancy and efficient capacity control
- Micro-channel condenser coils
- Vertical air discharge minimizes noise
- Three-phase condenser fan motors
- Field powered, 115 volt, GFI, electrical outlet
- Unit ships with nitrogen charge
- Fanrol (fan cycling head pressure controls to 45deg F)
- High and low pressure switch
- 24V terminal strip for field supplied installed controls
- Non-fused disconnect switch with through the door handle

Not Including/Quoting:

- Refrigerant
- TXV or EXV
- Sleepers
- Installation
- Refrigerant piping and specialties
- Extended compressor warranty

Tags	Description	Qty	Capacity	Lead Time
AHU-2	DAIKIN: CAH- Indoor Vision Air Handling	1	8,500 CFM	10 - 12 weeks

c/w

- Outside casing with G90 galvanized steel panel
- Liner with G90 galvanized solid internal liner
- 6" Base rail
- Insulation material (R-13 injected foam)

Supply Fan Section

- Plenum fan complete with VFD

22600705 DCDSB - Archbishop Denis O'Connor Owner Direct.
2026-04-22

- High efficiency motors
- Access door with window
- Marine light with switch (wiring by others)

- Cooling Coil Section
- Cooling coil
 - Access door
 - Stainless steel drain pan

- Filter Section
- 2" Merv 8 filters

- Mixing Section
- Low leak, insulated dampers

- Not Quoting/Including:**
- Single point power connection
 - Site assembly of sections (unit ships in multiple sections)
 - Flex duct connection on units with external isolation
 - External isolation
 - Rigging
 - Spare filters
 - Balancing sheaves
 - Controls unless specifically noted
 - External wiring
 - Sections/accessories not specifically noted

Tags	Description	Qty	Capacity	Lead Time
CU-2	DAIKIN: Air Cooled Condensing Unit	1	25 tons	16 - 18 weeks

- C/W
- High efficiency Copeland® scroll compressors
 - All units feature dual refrigeration circuits for redundancy and efficient capacity control
 - Micro-channel condenser coils
 - Vertical air discharge minimizes noise
 - Three-phase condenser fan motors
 - Field powered, 115 volt, GFI, electrical outlet
 - Unit ships with nitrogen charge
 - Fantrol (fan cycling head pressure controls to 45deg F)
 - High and low pressure switch
 - 24V terminal strip for field supplied installed controls
 - Non-fused disconnect switch with through the door handle

- Not Including/Quoting:**
- Refrigerant
 - TXV or EXV
 - Sleepers
 - Installation
 - Refrigerant piping and specialties
 - Extended compressor warranty

Tags	Description	Qty	Capacity	Lead Time
AHU-3 CC	DAIKIN: Cooling Coil	1	11,760 CFM	8 - 10 weeks

- C/W
- Aluminium fins
 - Copper tube
 - Copper headers
 - Copper connections
 - Stainless steel coil casing
 - Flanged casing connections

- Not Including/Quoting:**
- Hangers
 - Insulated coil enclosure (casing)
 - Drain pans
 - Coil racks
 - CRN

Tags	Description	Qty	Capacity	Lead Time
AHU-3 HC	DAIKIN: Heating Coil	1	11,760 CFM	8 - 10 weeks

- C/W
- Aluminium fins
 - Copper tube
 - Copper headers
 - Carbon steel MPT connections
 - Galvanized steel coil casing
 - Flanged connections

- Not Including/Quoting:**
- Hangers
 - Control valves

- Transitions
- Coil racks
- Insulated coil enclosure
- CRN

Tags	Description	Qty	Capacity	Lead Time
CU-3	DAIKIN: Air Cooled Condensing Unit	1	50 tons	16 - 18 weeks

- c/w
- High efficiency Copeland® scroll compressors
 - All units feature dual refrigeration circuits for redundancy and efficient capacity control
 - Micro-channel condenser coils
 - Vertical air discharge minimizes noise
 - Three-phase condenser fan motors
 - Field powered, 115 volt, GFI, electrical outlet
 - Unit ships with nitrogen charge
 - Fanrol (fan cycling head pressure controls to 45deg F)
 - High and low pressure switch
 - 24V terminal strip for field supplied installed controls
 - Non-fused disconnect switch with through the door handle

- Not Including/Quoting:**
- Refrigerant
 - TXV or EXV
 - Sleepers
 - Installation
 - Refrigerant piping and specialties
 - Extended compressor warranty

Tags	Description	Qty	Capacity	Lead Time
AHU-4 HC	DAIKIN: Heating Coil	1	2,600 CFM	8 - 10 weeks

- C/w
- Aluminium fins
 - Copper tube
 - Copper headers
 - Carbon steel MPT connections
 - Galvanized steel coil casing
 - Flanged connections

- Not Including/Quoting:**
- Hangers
 - Control valves
 - Transitions
 - Coil racks
 - Insulated coil enclosure
 - CRN

Spec Section: -- Daikin VRV

Tags	Description	Qty	Capacity	Spec Level
ODU-1	DAIKIN COMMERCIAL: 10 ton, 230V, VRV EMERION HP	1	0 tons	Basis of Design

- Daikin VRV condensing units provided with the following:**
- R-410a refrigerant factory charge in condensing units (remaining charge to be field installed)
 - RefNet™ refrigerant pipe manifolds factory supplied for field installation
 - 10 year parts and 10 year compressor warranty
 - 2-wire communications protocol (daisy chain of wiring not included in base price)
 - Factory Authorized Startup Services (details below)

NOTE:
 Daikin refrigerant piping system does not require field installation of piping specialties such as filter dryers, oil traps, solenoid valves, sight glasses, etc. The only fittings that should be contractor supplied are standard bends as required. Contractor shall provide copper pipe line sets, insulation on all lines and install Daikin provided splitters/headers, etc.

Tags	Description	Qty	Capacity	Spec Level
ACC-1	DAIKIN COMMERCIAL: AHU INTEGRATION VALVE KIT - 150 MBH	1	0 Each	Basis of Design
ACC-2	DAIKIN COMMERCIAL: W-CONTROL BOX (0-10V DDC CONTROL)	1	0 Each	Basis of Design

- R410a VRV System interlock with AHU**
- Daikin VRV control box and expansion valve kit for interlock between VRV condensing units and AHU
 - Control box is configured for Discharge Air Temperature / Return Air Temperature control
 - DAT control requires an external 0 - 10 VDC signal for capacity control- Control box requires 208-230/1/60 power feed
 - See AHU bill of materials for detailed performance of AHU (Control box and expansion valve kit ship loose for field installation and wiring by installing contractor) **AHU controls by others.**

ing and wiring by others.

*Please contact DXS if there are questions surrounding controls.

VRV rated DX coil

- Custom VRV rated DX coil for to allow interlock with VRV condensing units. Installation by others.

ITEMS NOT QUOTING:

- DX Piping and Refrigerant
- BAS Controls
- Isolation Valves for DX Piping
- Transformers for power supply
- Ductwork
- Low voltage control wire
- Disconnect switches for indoor and outdoor units
- Vibration isolation for indoor and outdoor units
- Installation, mounting or wiring
- Exterior wiring
- Condensate management (drain pans, pumps, piping) for Condensing units
- Spare parts

NOTE:

Daikin refrigerant piping system does not require field installation of piping specialties such as filter dryers, oil traps, solenoid valves, sight glasses, etc. The only fittings that should be contractor supplied are standard bends as required. Contractor shall provide copper pipe line sets, insulation on all lines and install Daikin provided splitters/headers, etc.

Tags	Description	Qty	Capacity	Lead Time
AHU-4 CC	CANCOIL: Cooling Coil	1	2,600 CFM	8 - 10 weeks

C/w

- Aluminium fins
- Copper tube
- Copper headers
- Copper connections
- Stainless steel coil casing
- Flanged casing connections

Not Including/Quoting:

- Hangers
- Insulated coil enclosure (casing)
- Drain pans
- Coil racks
- CRN

Spec Section: -- Rooftop Units

Tags	Description	Qty	Capacity	Lead Time
RTU-1	DAIKIN: Rebel Rooftop Systems	1	15 tons	16 - 18 weeks
RTU-2	DAIKIN: Rebel Rooftop Systems	1	16 tons	16 - 18 weeks
RTU-3	DAIKIN: Rebel Rooftop Systems	1	25 tons	16 - 18 weeks

C/w

- 1" double wall, low leakage, foam injected panels (R-7)
- Variable speed inverter scroll compressor
- Low-GWP R-32 refrigerant
- A2L leak mitigation controller
- Variable speed ECM motors on all fans (SF, EF, condenser fans)
- Electronic expansion valves
- Hinged access doors with 1/4 turn latches
- Full perimeter base rail
- Ultra-quiet condenser fans
- Double sloped SS drain pan
- Discharge air sensor (ships loose for field installation by mechanical contractor)
- 2" and 4" slide-out filter racks
- Daikin MicroTech unit controller
- 1 year parts and compressor warranty

Optional Features Included:

- Heat pump with hybrid hydronic heating
- Economizer (0-100%)
- 100% OA unit
- Energy recovery capacity control (wheel effectiveness)
- Energy recovery frost control modulating)
- Non-fused disconnect
- GFI receptacle (field powered)
- Controls communication
- 14" Roof curb

Not Including/Quoting:

- Condensate Heat Trading
- Condensate Piping
- Condensate Neutralizers
- mounting loose sensors shipped with unit
- Spare Filters
- Wiring/controls
- Commissioning

- Storage

Tags	Description	Qty	Capacity	Lead Time
RTU-7,8	DAIKIN: Rebel Rooftop Systems	2	CFM	16 - 18 weeks

C/w

- Double-wall construction for all panels. Floor panels with solid galv. Steel inner liner
- 2" R-13 insulation
- Pre-painted galv. Steel exterior surfaces
- Outdoor applications (weatherproof cabinet)
- Hinged service doors on mechanical sections
- 2" MERV 13 filters
- Microtech III control
- 12-month, parts only warranty

Optional Features Included:

- Variable volume (single zone)
- Gas heat
- Economizer (0-100%)
- Non-fused disconnect
- GFI receptacle (unit powered, field powered)
- Roof curb
- BACnet MSTP
- Space sensor with tenant setpoint override
- Start-up

Not Including/Quoting:

- Spare Filters
- Seismic engineering/hardware
- Variable frequency drives (not required)
- Installation/rigging
- Wiring/controls
- Commissioning
- Storage

Spec Section: -- Energy Recovery Ventilators

Tags	Description	Qty	Capacity	Lead Time
ERV-1 (AHU-1)	ALDES: Advanced Series	1	14,500 CFM	16 - 18 weeks
ERV-2 (AHU-2)	ALDES: Advanced Series	1	4,250 CFM	16 - 18 weeks

C/w

- High-efficiency enthalpic heat recovery wheel
- Outdoor construction
- Painted 22GA galvanized steel
- 1" drain connection
- Forward-curved blowers
- Belt drive inverter ready motors, premium efficiency, VFDs included
- 575V power
- Merv 8 filters on exhaust and outdoor air streams
- Motorized intake/exhaust dampers
- 24 VAC, 10 VA contact for supply and exhaust dampers
- Dry contacts for (occupancy control, fan interlock, speed selection)
- 14" Roof curb

Not Including

- External controls or wiring
- Controls

-- End of Base Equipment Detail --

Terms and Conditions

1. **Company:** The term "Company" as used herein shall mean HTS Engineering Ltd.
2. **Terms of Agreement:** Any additional, differing, contrary or conflicting terms or conditions contained in any other document prepared, submitted or signed by the Purchaser, including, but not limited to, purchase orders, other forms of purchase or contracts, including, but not limited to, prime contracts or CCDC contracts (whether or not such terms or conditions materially alter this offer), are hereby rejected by the Company and shall not become part of the contract between Purchaser and the Company.
3. **Price Policy:** Price is in effect for 15 days from time of quote. All prices may be increased, depending on the date of release and/or shipment of the order, due to such events as announced increases in the Company's list prices, or increases in labour or material costs.
4. **Terms of Payment:** Terms of payment are subject at all times to prior approval of the Company's credit department. Terms of payment are net 30 days of the date of the invoice with the exception of tariff invoices which are COD, unless previously otherwise agreed to in writing by the Company. If at any time the financial condition of the Purchaser or other circumstance affecting the credit decision, in the Company's opinion, does not justify continuance of production of products, shipment of products or provision of services, on the terms of payment specified, the Company may require full or partial payment in advance, or may, at its sole discretion, stop or delay production, shipment of products or provision of services. In the event of default in payment, the Purchaser agrees to pay all costs of collection incurred by the Company including, but not limited to, collection agency fees, lawyer/attorney fees (on a full indemnity basis), legal costs, and court costs. All past due amounts shall bear interest at a rate of prime plus eighteen per cent (18%) per annum, or at the highest interest rate allowed by law.
5. **Shipping Terms:** All shipments will be made F.O.B. Factory or warehouse with freight prepaid as quoted. All shipments will be made via a low cost common carrier and charges for special carrier services requested by the Purchaser shall be paid by the Purchaser. The Company may ship the goods in one or more lots. Such lots may be separately invoiced and shall be paid for when due per invoice, without regard to subsequent deliveries. Delay in the delivery of any lot shall not relieve the Purchaser of its obligation to accept remaining deliveries. If, because of the Purchaser, any shipment must be diverted or returned to the Company, the Purchaser shall pay all demurrage, transportation and other costs incurred as a result thereof.
6. **Storage:** At the Company's sole option, and without prejudice to the Company's ability to pursue all available remedies for breach of this contract or these terms and conditions, if any goods purchased hereunder remained unclaimed by the Purchaser for 14 days after notification by the Company that they are ready for delivery, the Purchaser shall pay the Company as storage charges an amount equal to 2% of the total purchase price hereunder, per month, to be billed and paid monthly.
7. **Claims:** The responsibility of the Company for all shipments ceases upon delivery of the goods to the carrier. Since all goods are shipped at the Purchaser's risk, damage or shortage in transit must be filed by the Purchaser against the carrier and not the Company. Claims for factory shortages will not be considered unless made in writing to the Company within ten (10) days after receipt of the goods and accompanied by reference to the Company's bill of lading and factory order numbers.
8. **Taxes:** The amount of any present or future taxes applicable to the product or services shall be added to the price contained herein and paid by the Purchaser in the same manner and with the same effects as if originally added thereto.
9. **Cancellations:** Accepted orders are not subject to cancellation without the Company being reimbursed for any and all expenses, including overhead, and being indemnified by the Purchaser against any and all loss.
10. **Shipment Dates:** Shipment dates are only estimates. No contract has been made to ship in a specified time unless in writing, and signed by two (2) officers of the Company. The Company shall not be liable for any damages as a result of any delay or failure to deliver due to disapproval of the Company's credit department or due to any cause beyond the Company's reasonable control, including, but not limited to, any act of God, act of the Purchaser, governmental act, accident, labour unrest, delay in transportation, or inability to obtain the necessary labour, materials or manufacturing facilities.
11. **Product Changes:** In the interest of continuous product improvements, the Company reserves the right to change specifications and/or design without incurring obligation.
12. **Returned Goods:** Goods may not be returned except with advance written permission of an authorized Company official, and when so returned will be subject to handling and transportation charges. Authorized return goods must be shipped prepaid to the location designated by the authorization.
13. **Limited Warranty:** Subject to sections 14 and 15 herein, free replacement parts will be provided by the manufacturer the Company represents in the event any product supplied by the Company and used in Canada proves defective in material or workmanship for a period of twelve (12) months from the initial start-up or eighteen (18) months from the date of shipment, whichever expires sooner. Replaced parts are warranted for the duration of the original warranty period. This warranty constitutes the purchaser's sole remedy. It is given in lieu of all other warranties, express or implied. There is no implied warranty of merchantability or fitness for a particular purpose. No liability, or obligation under the Company's warranty, shall attach to the Company until the Company has been paid in full for all products and services purchased hereunder. No person has the authority to expand the Company's obligation beyond the terms of this express warranty. The Company must receive a start-up information report for goods containing motor-compressors and/or furnaces. The registration/start-up form must be completed and returned to the Company within ten (10) days of original equipment start-up, or start-up date and ship date will be deemed the same for warranty determination, and the warranty shall expire twelve (12) months from that date. Goods sold under this agreement are warranted only to the extent that the manufacturer warranted them to the Company or directly to the Purchaser.
14. **Warranty Exclusions:** The Company's warranty set forth in section 10 hereof, does not apply to any goods which have been opened, disassembled, repaired, or altered by anyone other than the Company or its authorized service representative; or which have been subjected to misuse, misapplication, abuse, negligence, accidents, damage, or abnormal use or service; or have been operated, installed, or start-up has been provided in a manner contrary to the Company's printed instructions. The Company is not obligated to pay any labour or service costs for removing or replacing parts, or any shipping charges. Refrigerants, fluids, oils, and expendable items such as filters are not covered by the Company's warranty. This parts warranty and any optional extended warranties are granted only to the original user. The Company's duty to perform under any warranty may be delayed, at the Company's sole option, until the Company has been paid in full for all goods purchased by Purchaser. No such delay shall extend the warranty period. For additional consideration the Company will provide an extended warranty(ies) on certain goods or components thereof. To obtain assistance under this limited warranty please contact HTS Engineering 115 Norfinch Drive, Toronto, Ontario, M3N 1W8, Tel: (416) 661-3400.
15. **Limitations on Liability:** The Company's liability with respect to the goods and services sold hereunder shall be limited to the warranty provided in section 10 hereof, and shall not exceed the lesser of the cost of correcting defects in the goods sold or the original purchase price of the goods, and the Company shall not in any event be liable to Purchaser or third parties for any delays of special, indirect, or consequential damages. In no event and under no circumstances shall the Company be liable for incidental or consequential damages, whether the theory be breach of this or any other warranty, negligence, or strict tort.
16. **No Holdbacks:** The Company does not accept any holdbacks from its billings (see "Terms of Payment" above). The Company is a supplier (not a "contractor" as defined in the Construction Lien Act) and is NOT subject to the holdback rules contained in the Construction Lien Act.
17. **Waiver:** No waiver, alteration or modification of these terms and conditions shall be valid unless made in writing and signed by an authorized officer of the Company.
18. **Project Design and Specifications:** The Company does not accept any order subject to project design and specifications. The Purchaser agrees to accept full and sole responsibility to determine whether the product ordered by the Purchaser meets the design and specification requirements of any project.
19. **Permits:** The Purchaser shall be responsible for obtaining all necessary permits and approvals as may be required for the installation of any goods or services provided hereunder and shall obtain the requisite permits or approvals at their own expense. The Purchaser shall indemnify and hold harmless the Company from any and all loss, cost, expense, and damages as account of any and all matter of claims, demands, actions or proceedings that may be instituted against the Company on grounds alleging that the installation of the products and services provided by the Company were completed without the requisite permits and approvals.
20. **Entire Agreement:** This contract and these terms and conditions shall constitute the entire agreement between the Purchaser and the Company and supersede all prior or contemporaneous oral or written agreements, representations, promises, warranties and statements of any kind whatsoever made by the Company and shall not be supplemented by any course of dealing or performance or usage of trade. There are no provisions, warranties, representations, promises or inducements except such as are expressly provided herein.
21. **Severability:** If any provision of this contract or these terms and conditions is held to be invalid or unenforceable, the remaining provisions shall remain unaffected, and in full force and effect.
22. **Jurisdiction:** This contract and these terms and conditions of sale shall be governed and interpreted by the laws of the Province of Ontario and all actions and other legal proceedings relating directly or indirectly to this contract and these terms and conditions shall be determined and brought exclusively in the courts of the Province of Ontario.



Submittal # 98343

APPROVAL REQUIRED

Project 22600705-OWN-1- DCDSB - Archbishop Denis O'Connor
Leader Curtis Metrow
Job Site 80 Mandrake St, Ajax, ON, Canada
Submission Date 2026-04-01
Sold To DURHAM CDSB *
Submitted By Curtis Metrow

Contacts

Role	Customer	Our Rep
Owner	Durham Catholic District School Board *	Curtis Metrow
Designer	Ellard Willson Engineering	Steve Cukrovani

Deliverables

Track #	335956		
Tag	RTU-1, RTU-2, RTU-3		
Description	Rebel Rooftop Systems		
Quantity	3		
Manufacturer	Daikin Applied		
Specification			
Production Lead Time	16 - 18 Weeks		
Revision #	1		

Attention:

- 1) HTS will provide equipment in accordance with the attached shop drawings.
- 2) Upon approved submittal and customer release, HTS will release equipment to fabrication per the published lead times. Any storage fees associated with project schedule changes will be the responsibility of the purchaser.
- 3) HTS can provide freight and logistics to the purchaser as an added benefit of doing business with HTS. When freight is received by the purchaser, any noticeable damage must be recorded. Otherwise, HTS is not responsible for subsequent damage claims.

Approval Stamps

RYBKA ELLARD WILLSON INC		
<input type="checkbox"/> REVIEWED		
<input checked="" type="checkbox"/> REVIEWED AS NOTED		
<input type="checkbox"/> REVISE AND RESUBMIT		
<hr/>		
<p>SUBMITTAL WAS REVIEWED FOR DESIGN CONFORMITY AND GENERAL CONFORMANCE TO CONTRACT DOCUMENTS ONLY. THE CONTRACTOR IS RESPONSIBLE FOR CONFIRMING AND CORRELATING DIMENSIONS AT JOB SITES FOR TOLERANCES, CLEARANCES, QUANTITIES, FABRICATION PROCESSES AND TECHNIQUES OF CONSTRUCTION, COORDINATION OF THEIR WORK WITH OTHER TRADES AND FULL COMPLIANCE WITH THE CONTRACT DOCUMENTS.</p>		
<hr/>		
BY JMACQUARRIE	DATE 2026/04/06	

RYBKA ELLARD WILLSON INC		
<input checked="" type="checkbox"/> REVIEWED		
<input type="checkbox"/> REVIEWED AS NOTED		
<input type="checkbox"/> REVISE AND RESUBMIT		
<hr/>		
<p>SUBMITTAL WAS REVIEWED FOR DESIGN CONFORMITY AND GENERAL CONFORMANCE TO CONTRACT DOCUMENTS ONLY. THE CONTRACTOR IS RESPONSIBLE FOR CONFIRMING AND CORRELATING DIMENSIONS AT JOB SITES FOR TOLERANCES, CLEARANCES, QUANTITIES, FABRICATION PROCESSES AND TECHNIQUES OF CONSTRUCTION, COORDINATION OF THEIR WORK WITH OTHER TRADES AND FULL COMPLIANCE WITH THE CONTRACT DOCUMENTS.</p>		
<hr/>		
BY FCHANG	DATE 2026/04/06	

REW COMMENTS:

- ROOF CURB ADAPTORS FOR RTU-1,2,3
- CONTROLS: BACNET IP
- RTU-1: HC TO CHANGE TO TWO ROW



HTS Oshawa

2001 Thickson Rd, South
Unit #11
Whitby, ON L1N 6J3
T 905.579.6700
F 905.597.5290

ontario.htseng.com

SUBMITTAL DATA
APPROVAL REQUIRED

SEMI CUSTOM ENERGY RECOVERY AIR SOURCE HEAT PUMP

RTU-1,2,3

Technical Information And Drawings

Notes:

- 1) Electrical:
 - a. A 575/3/60 electrical feed is required per unit
 - i. RTU-1 MCA = 41.7A / MOP = 60A / SCCR = 10kAIC
 - ii. RTU-2 MCA = 45.5A / MOP = 60A / SCCR = 10kAIC
 - iii. RTU-3 MCA = 60A / MOP = 70A / SCCR = 10kAIC

- 2) Unit Information:
 - a. Air source heat pump c/w/ glycol backup heating coil
 - b. Energy recovery wheel
 - c. Filter rack – 2” MERV 13 filter on supply, 2” MERV 8 filter on exhaust
 - d. Exhaust fan c/w/ ECM Motors
 - e. Supply fan c/w/ ECM motors
 - f. Modulating VRF compressor control
 - g. Modulating hot gas reheat
 - h. Bottom supply & return duct connections
 - i. 14” Roof curb ← **REW: CURB ADAPTOR**

- 3) Controls
 - a. Integral unit controller
 - i. Discharge air temperature control – sensor shipped loose for field installation
 - ii. Building/room air pressure control (tubing by others) for exhaust fan control
 - b. Controller is complete with integral operators LCD – password protected
 - c. BMS integration via **BACnet IP or MSTP to be confirmed prior to release.** ← **REW: BACnet IP**

- 4) Warranty:
 - a. 2 year factory parts warranty included

Job Information	Technical Data Sheet
-----------------	----------------------

Job Name	22600705 - DCDSB Archbishop Dennis Oconnor
Date	4/1/2026
Submitted By	Terry Loyala
Software Version	14.10
Unit Tag	RTU-1 50% ODA



Unit Overview						
---------------	--	--	--	--	--	--

Model Number	Cabinet	Voltage V/Hz/Phase	Design Cooling Capacity Btu/hr	AHRI 340/360 Standard Efficiency		ASHRAE 90.1-2022 Compliant
				EER	IEER	
DPSH15B	B	575/60/3	169430	11.4	20.4	ASHRAE 90.1-2022 compliant

Unit	
------	--

Model Number:	DPSH15B
Model Type:	Heat Pump
Heat Type:	Hot Water
Hot Gas Reheat:	MHGRH
Energy Recovery:	ERW-Med Cab-Econ: 2835 cfm max, 100% OA: 5145 cfm max
Application:	Variable Air Volume, Single Zone (Mixed Air or 100% OA)
Controls:	Microtech
Outside Air:	0-100% Economizer with Drybulb Control
Altitude:	0 ft
Approval	cETLus

Physical			
----------	--	--	--

Dimensions and Weight			
Length	Height	Width	Weight
121.6 in	85.9 in	73.4 in	3177 lb
Corner Weights			
L1	L2	L3	L4
1073 lb	661 lb	550 lb	894 lb
Construction			
Exterior	Insulation and Liners	Air Opening Location	
		Return	Supply
Painted Galvanized Steel	1" Injected Foam, R-7, Galvanized Steel Liner	Bottom	Bottom

Electrical			
------------	--	--	--

Unit FLA	MCA	MROPD	SCCR
36.6 A	41.7 A	60 A	10 kAIC
Note:	Use only copper supply wires with ampacity based on 75° C conductor rating. Connections to terminals must be made with copper lugs and copper wire.		

Return/Outside/Exhaust Air

Outside Air Option			
Type	Damper Pressure Drop	Exhaust Air Type	
90.1 and California Title 24 Compliant Economizer	0.20 inH ₂ O	Airfoil Power Exhaust Fan	
Type	Drive Type	Wheel Diameter	Fan Series
SWSI AF	Direct Drive	18 in	Series II
Motor			
(Qty) Horsepower	Type	Efficiency	Full Load Current (Each)
(1) 7.0 HP	ECM - Series I	Premium	5.6 A
Performance			
Air Flow CFM	External Static Pressure inH ₂ O	Fan Speed RPM	Brake Horsepower HP
5000	2.00	2227	4.02

Energy Recovery

Design OA Volume	Design Exhaust Volume	Wheel Pressure Drop	Motor HP	Motor FLA						
2500 CFM	2500 CFM	1.11 inH ₂ O	0.17 HP	0.9 A						
Summer Conditions										
Temperature								Recovered Capacity Btu/hr	Effectiveness	
Outside Air		Return Air		Wheel Leaving		Mixed Air			Total	Sensible
Dry Bulb °F	Wet Bulb °F	Dry Bulb °F	Wet Bulb °F	Dry Bulb °F	Wet Bulb °F	Dry Bulb °F	Wet Bulb °F			
95.0	75.0	75.0	62.0	80.6	66.3	77.8	64.2	82621	0.69	0.71
Winter Conditions										
Temperature								Recovered Capacity Btu/hr	Effectiveness	
Outside Air		Return Air		Wheel Leaving		Mixed Air			Total	Sensible
Dry Bulb °F	Wet Bulb °F	Dry Bulb °F	Wet Bulb °F	Dry Bulb °F	Wet Bulb °F	Dry Bulb °F	Wet Bulb °F			
-4.0	-5.0	72.0	54.0	48.9	40.1	60.5	47.5	186229	0.72	0.72
Bypass Damper:		Yes								
Energy Recovery Filters										
Efficiency	Quantity/Size				Face Area		Face Velocity		Air Pressure Drop	
	Outdoor	Exhaust	Outdoor	Exhaust	Outdoor ft ²	Exhaust ft ²	Outdoor ft/min	Exhaust ft/min	Outdoor inH ₂ O	Exhaust inH ₂ O
2 in. MERV 8	(2) 18 in. X 24 in.	(2) 18 in. X 24 in.			6.0	6.0	416.7	416.7	0.20	0.20

Filter Section

Physical				
Type	Quantity / Size	Face Area	Face Velocity	Air Pressure Drop
2" ONLY RACK - with MERV13 factory filters. Is NOT a combo rack.	6 / 18 in x 24 in x 2 in	18.0 ft ²	277.8 ft/min	0.15

DX Cooling Coil

Physical

Coil Type	Refrigerant Type	Fins per Inch	Rows	Face Area	Face Velocity	Air Pressure drop	Drain Pan Material	UV Light
Cu Tube/ Al Fin	R32	12	6	15.4 ft ²	324.0 ft/min	0.37 inH ₂ O	Stainless Steel	None

Cooling Performance

Capacity			Indoor Air Temperature					Ambient air Temperature °F
Total Btu/hr	Sensible Btu/hr	Moisture Removal lb/h	Entering		Leaving			
			Dry Bulb °F	Wet Bulb °F	Dry Bulb °F	Wet Bulb °F	Dewpoint °F	
169430	134416	31.5	77.8	64.2	52.1	52.1	52.1	95.0

Condensate Connection Size: 3/4 in. Male NPT

Heating Performance

Total Capacity Btu/hr	Refrigerant Type	Indoor Air Temperature Dry Bulb		Ambient Air Temperature °F
		Entering °F	Leaving °F	
164500	R32	70.0	100.3	47.0

Hot Gas Reheat Coil Section

Type	Face Area	Air Pressure Drop	Total Capacity	Leaving Air Temperature	
				Dry Bulb	Wet Bulb
Aluminum Tube Micro-Channel	14.8 ft ²	0.08 inH ₂ O	97075 Btu/hr	70.0 °F	59.0 °F

Fan Section

Fan				
Type	Fan Wheel Diameter	Fan Series	Fan Isolation	
SWSI AF	18 in	Series II	None	
Performance				
Airflow	Total Static Pressure	Fan Speed	Brake Horsepower	Altitude
5000 CFM	5.0 inH ₂ O	2539 rpm	6.15 HP	0 ft
Motor				Drive
Type	Horsepower	Efficiency	FLA	Type
ECM Motor	7.0	Premium	5.6 A	Direct Drive

Hot Water Heat Section

Physical					
Fins per Inch	Sweat Connection	Number of Rows	Face Area	Face Velocity	Air Pressure Drop
8	1.375 in	1	5.4 ft ²	925.9 ft/min	0.22 inH ₂ O
Performance					
Total Capacity Btu/hr	Temperature				
	Entering		Leaving		
	Air Dry Bulb °F	Fluid °F	Air Dry Bulb °F	Fluid °F	
97380	40.0	170.0	57.8	150.0	
Type	Glycol Concentration %	Flow Rate gpm	ft H ₂ O		
Propylene Glycol	40.0	10.5	1.5		

Unit Discharge Conditions

Air Temperature				
Motor Heat Btu/hr	Moisture Removal lb/h	Unit Leaving Dry Bulb °F	Unit Leaving Wet Bulb °F	Unit Leaving Dewpoint °F
17443	31.5	55.3	53.2	52.1
Minimum Airflows				
Notes:	Refer to fan curve for applicability of approximate airflows			

REW: CHANGE TO TWO ROW COIL.

Condensing Section

Compressor						
Type	Quantity	Refrigerant Charge lb	Total Power	Capacity Control	Compressor Isolation	
Inverter Scroll	1	33.7	10.95 kW	Mod Control with Inverter Compressor	Rubber in Shear	
Compressor Amps:						
Compressor 1			20.4 A			
Condenser Coil						
Type	Fins per Inch			Fin Material		
Copper Tube - Aluminum Fin	23			Aluminum		
Condenser Fan Motors						
Number of Motors			Full Load Current (Total)			
2			2.8 A			
AHRI 340/360 Certified Data at AHRI 340/360 Standard Conditions						
Net Capacity	EER	IEER	Heat Net Capacity at 47°F	COP at 47°F	Heat Net Capacity at 17°F	COP at 17°F
166000 Btu/hr	11.4	20.4	157372 Btu/hr	3.6	113401 Btu/hr	2.3

Internal Pressure Drop Calculation

External Static Pressure:	2.00 inH ₂ O
Filter:	0.15 inH ₂ O
Outside Air:	0.20 inH ₂ O
DX Coil:	0.37 inH ₂ O
Hot Gas Reheat:	0.08 inH ₂ O
Hot Water Heat:	0.22 inH ₂ O
Total Static Pressure:	5.02 inH ₂ O

Sound

Frequency	Sound Power (db)							
	63 Hz	125 Hz	250 Hz	500 Hz	1 kHz	2 kHz	4 kHz	8 kHz
Inlet	87	85	93	88	90	84	79	73
Discharge	87	88	96	93	96	90	87	81
Radiated	85	85	81	78	77	73	70	60

Options

Electrical	
Field Connection:	Single Disconnect
Controls	
Communication Card:	BACnet IP

Factory Installed Sensors

Leaving Coil/Entering Fan Temperature Sensor
Duct High Limit Switch
Return Air Temperature Sensor
Discharge Air Temperature sensor – Wired in unit, mounted in supply duct
Outside Air Temperature Sensor
Dirty Filter On/Off Switch
Supply Fan Air Proving Via Modbus
Building Static Pressure Sensor
Supply Leaving Wheel Temperature Sensor
Exhaust Leaving Wheel Temperature Sensor
Return Air Relative Humidity Sensor
Energy Wheel VFD

Warranty

Parts: Standard One Year

Compressor: Standard One Year

Specials

Unit

Specials Description:

Notes

Forklift slots to remove unit from a truck bed. The fork lift slots are not to be used to place unit on a roof curb. Unit is to be lifted onto curb per IOM instructions.

Daikin Fan Selection

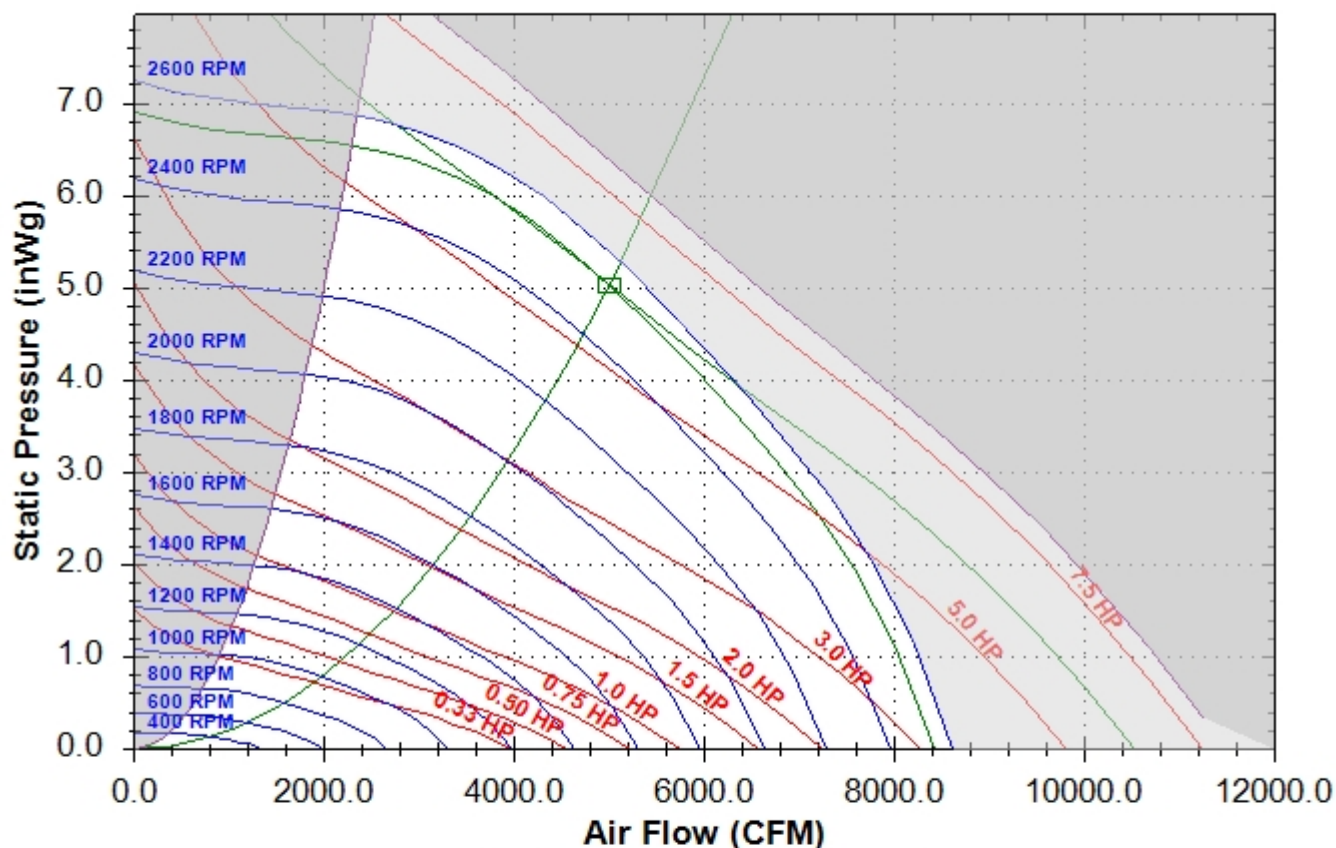

18.0 SWSI AF Supply Fan at Standard Conditions									
Base Tag	RTU-1 50% ODA				Date	Apr-01-2026			
Job Name	22600705 - DCDSB Archbishop Denni...				Time	9:21 PM			
Air Volume	5000	CFM			Fan Speed	2539	RPM		
Total Static	5.02	inWg			Max Speed	2600	RPM		
Brake Horsepower	6.15	HP			Efficiency	64	%		
Unit Sound Power		63hz	125hz	250hz	500hz	1000hz	2000hz	4000hz	8000hz
Inlet Sound Power		87	85	93	88	90	84	79	73
Outlet Sound Power		87	88	96	93	96	90	87	81
Radiated Sound Power		85	85	81	78	77	73	70	60

Daikin Fan Selection

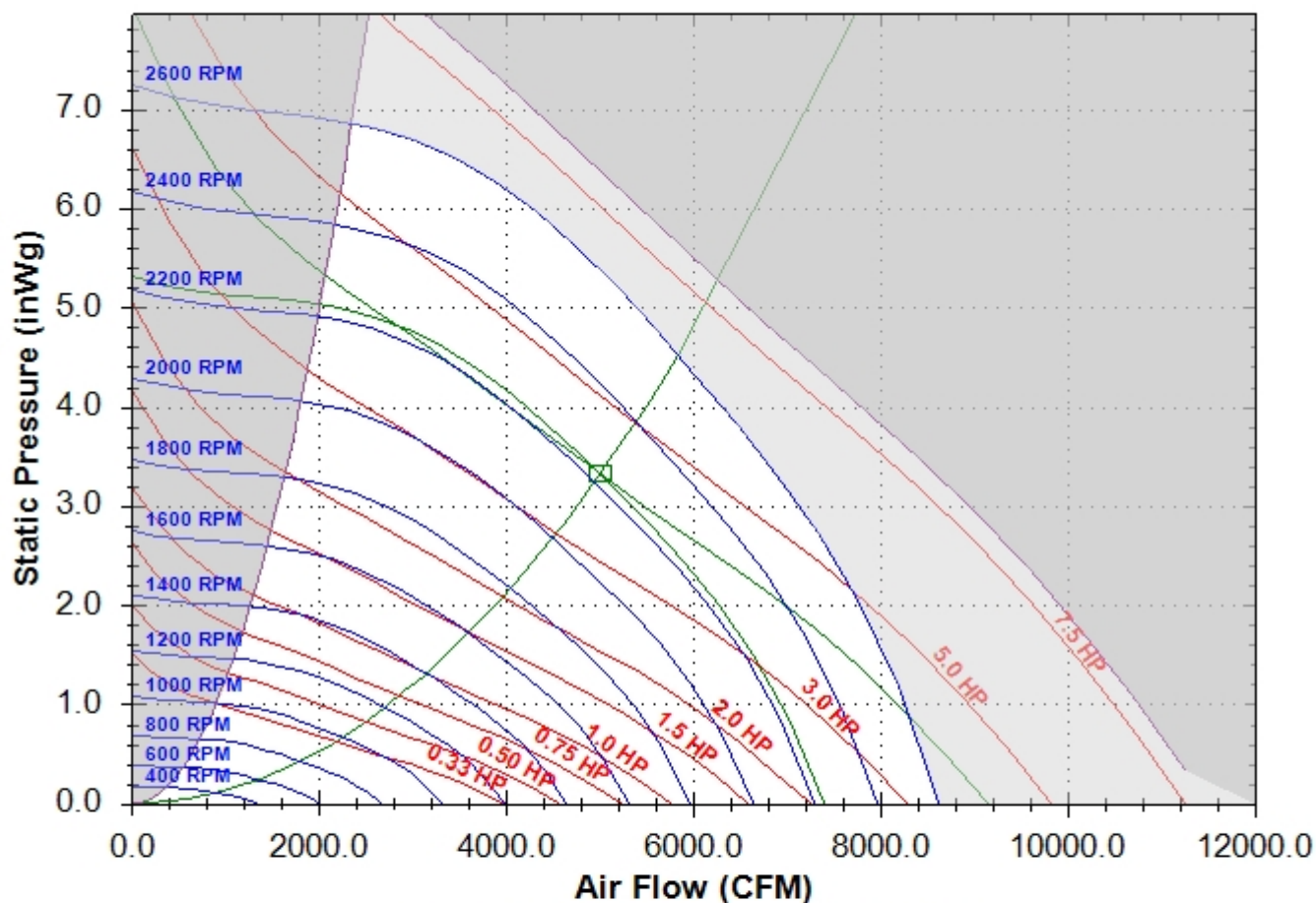

18.0 SWSI AF Exhaust Fan at Standard Conditions

Base Tag	RTU-1 50% ODA	Date	Apr-01-2026	
Job Name	22600705 - DCDSB Archbishop Denni...	Time	9:21 PM	
Air Volume	5000 CFM	Fan Speed	2227	RPM
Total Static	3.3 inWg	Max Speed	2600	RPM
Brake Horsepower	4.02 HP	Efficiency	65	%



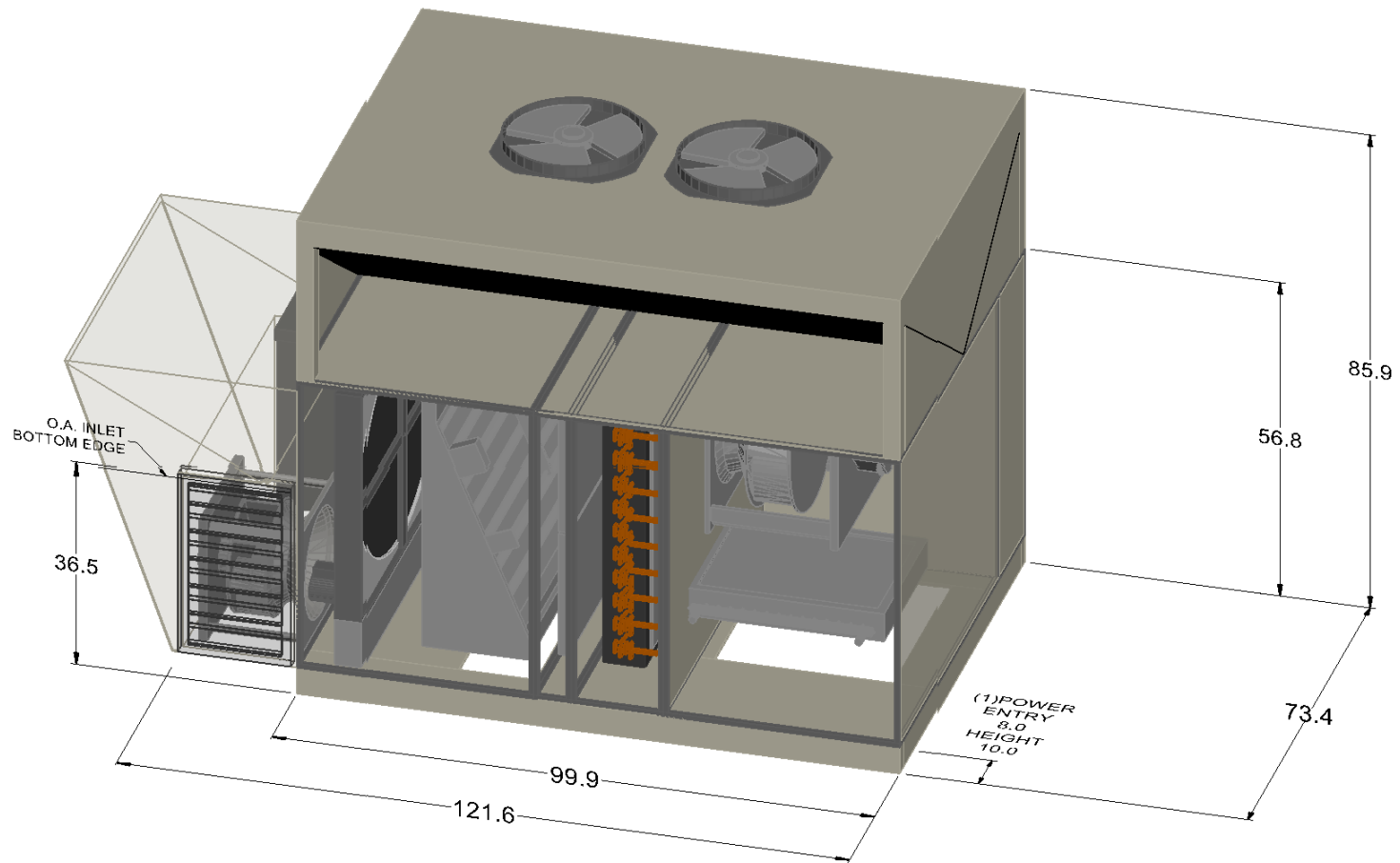



Notes:

(1) Recommended location for optional field cut side power connection.

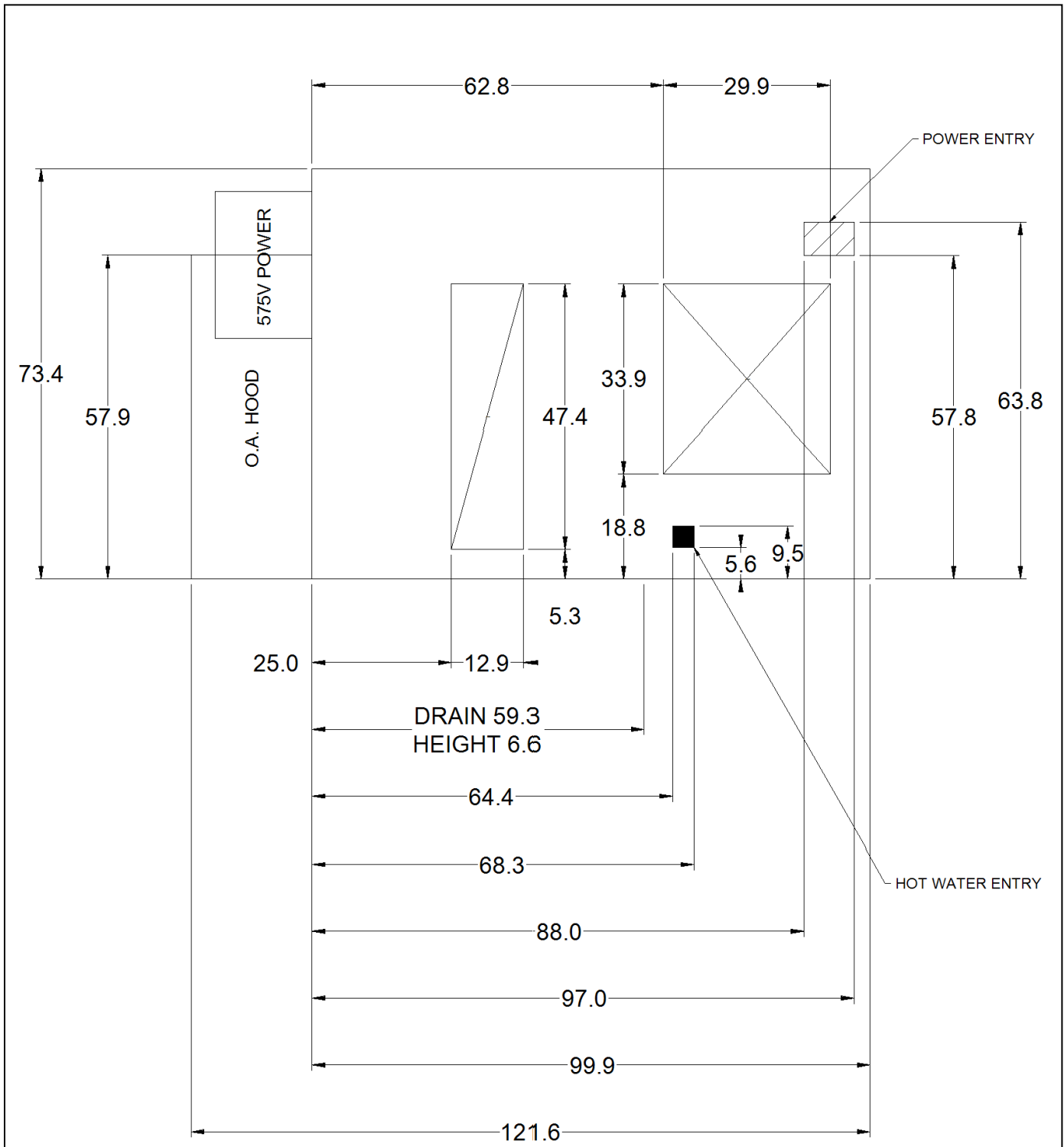
	Unit Tag: RTU-1 50% ODA			Sales Office: HTS Engineering Ltd.			 13600 Industrial Park Blvd. Minneapolis, MN 55441 www.DaikinApplied.com Software Version: 14.10
Product: Rebel	Project Name: 22600705 - DCDSB Archbishop			Sales Engineer:			
Model: DPSH15B	Apr. 01, 2026	Ver/Rev:	Sheet: 1 of 1	Scale: NTS	Tolerance: +/- 0.25"	Dwg Units: in [mm]	
No change to this drawing may be made unless approved in writing by Daikin Applied. Purchaser must determine that the equipment is fit and sufficient for the job specifications.							



PLAN VIEW - OPENINGS & OVERALL

Product: Rebel		Unit Tag: RTU-1 50% ODA		 13600 Industrial Park Blvd. Minneapolis, MN 55441 www.DaikinApplied.com Software Version: 14.10		
Model: DPSH15B		Project Name: 22600705 - DCDSB				
Sales Engineer: SalesEngineer		Sales Office: HTS Engineering Ltd.		Scale: NTS Tolerance: +/-0.25" Dwg Units: in [mm]		
		Apr. 01, 2026	Ver/Rev:	Sheet 1 of 1		
No change to this drawing may be made unless approved in writing by Daikin Applied. Purchaser must determine that the equipment is fit and sufficient for the job specifications.						

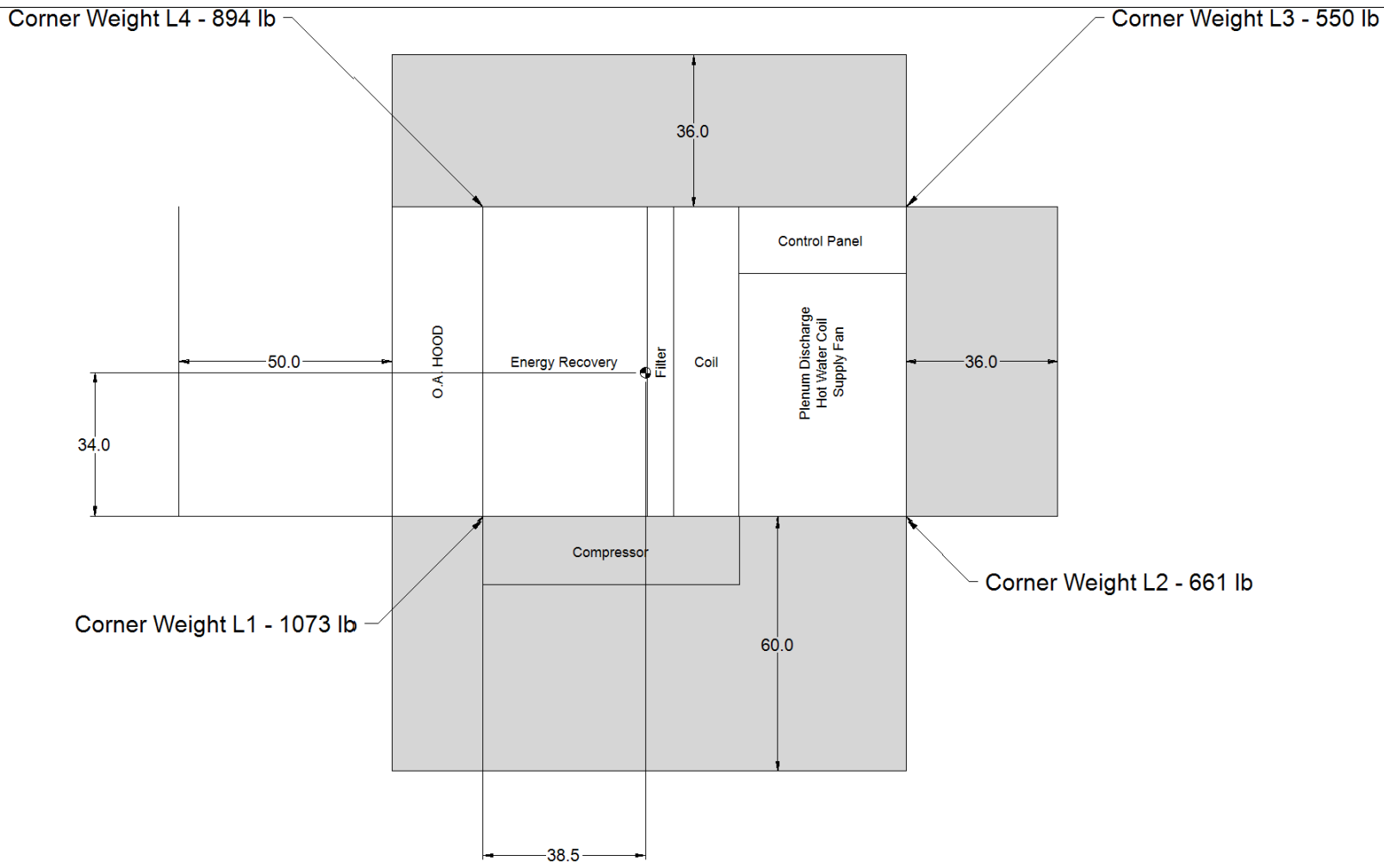

PLAN VIEW - CG, CORNER WEIGHTS, SERVICE CLEARANCE

Notes:

- (1) Center of Gravity Height = 25.7
- (2) Total Weight = 3177 lb

	Unit Tag: RTU-1 50% ODA			Sales Office: HTS Engineering Ltd.			 13600 Industrial Park Blvd. Minneapolis, MN 55441 www.DaikinApplied.com Software Version: 14.10
Product: Rebel	Project Name: 22600705 - DCDSB Archbishop			Sales Engineer:			
Model: DPSH15B	Apr. 01, 2026	Ver/Rev:	Sheet: 1 of 1	Scale: NTS	Tolerance: +/- 0.25"	Dwg Units: in [mm]	
No change to this drawing may be made unless approved in writing by Daikin Applied. Purchaser must determine that the equipment is fit and sufficient for the job specifications.							

Job Information		Technical Data Sheet
Job Name	22600705 - DCDSB Archbishop Dennis Oconnor	
Date	4/1/2026	
Submitted By	Terry Loyala	
Software Version	14.10	
Unit Tag	RTU-2 50% ODA	



Unit Overview						
Model Number	Cabinet	Voltage V/Hz/Phase	Design Cooling Capacity Btu/hr	AHRI 340/360 Standard Efficiency		ASHRAE 90.1-2022 Compliant
				EER	IEER	
DPSH16B	C	575/60/3	199161	11.0	21.2	ASHRAE 90.1-2022 compliant

Unit	
Model Number:	DPSH16B
Model Type:	Heat Pump
Heat Type:	Hot Water
Hot Gas Reheat:	MHGRH
Energy Recovery:	ERW-Large Cab-Econ: 5145cfm max, 100% OA: 8820 cfm max
Application:	Variable Air Volume, Single Zone (Mixed Air or 100% OA)
Controls:	Microtech
Outside Air:	0-100% Economizer with Drybulb Control
Altitude:	0 ft
Approval	cETLus

Physical			
Dimensions and Weight			
Length	Height	Width	Weight
222.5 in	72.1 in	76.5 in	4711 lb
Corner Weights			
L1	L2	L3	L4
1861 lb	1642 lb	566 lb	642 lb
Construction			
Exterior	Insulation and Liners	Air Opening Location	
		Return	Supply
Painted Galvanized Steel	2" Injected Foam, R13, Galvanized Steel Liner	Bottom	Bottom

Electrical			
Unit FLA	MCA	MROPD	SCCR
41.1 A	45.5 A	60 A	10 kAIC
Note:	Use only copper supply wires with ampacity based on 75° C conductor rating. Connections to terminals must be made with copper lugs and copper wire.		

Return/Outside/Exhaust Air

Outside Air Option			
Type	Damper Pressure Drop	Exhaust Air Type	
90.1 and California Title 24 Compliant Economizer	0.23 inH ₂ O	Airfoil Power Exhaust Fan	
Type	Drive Type	Wheel Diameter	Fan Series
SWSI AF	Direct Drive	18 in	Series II
Motor			
(Qty) Horsepower	Type	Efficiency	Full Load Current (Each)
(1) 7.0 HP	ECM - Series I	Premium	5.6 A
Performance			
Air Flow CFM	External Static Pressure inH ₂ O	Fan Speed RPM	Brake Horsepower HP
6800	2.00	2574	5.65

Energy Recovery

Design OA Volume	Design Exhaust Volume	Wheel Pressure Drop	Motor HP	Motor FLA						
3400 CFM	3400 CFM	0.90 inH ₂ O	0.17 HP	0.9 A						
Summer Conditions										
Temperature								Recovered Capacity Btu/hr	Effectiveness	
Outside Air		Return Air		Wheel Leaving		Mixed Air			Total	Sensible
Dry Bulb °F	Wet Bulb °F	Dry Bulb °F	Wet Bulb °F	Dry Bulb °F	Wet Bulb °F	Dry Bulb °F	Wet Bulb °F			
95.0	75.0	75.0	62.0	82.0	67.2	78.5	64.7	100818	0.62	0.64
Winter Conditions										
Temperature								Recovered Capacity Btu/hr	Effectiveness	
Outside Air		Return Air		Wheel Leaving		Mixed Air			Total	Sensible
Dry Bulb °F	Wet Bulb °F	Dry Bulb °F	Wet Bulb °F	Dry Bulb °F	Wet Bulb °F	Dry Bulb °F	Wet Bulb °F			
-4.0	-5.0	72.0	54.0	43.0	36.1	57.5	45.8	226829	0.64	0.65
Bypass Damper:		Yes								
Energy Recovery Filters										
Efficiency	Quantity/Size				Face Area		Face Velocity		Air Pressure Drop	
	Outdoor	Exhaust	Outdoor	Exhaust	Outdoor ft ²	Exhaust ft ²	Outdoor ft/min	Exhaust ft/min	Outdoor inH ₂ O	Exhaust inH ₂ O
2 in. MERV 8	(2) 18 in. X 24 in.	(2) 18 in. X 24 in.			6.0	6.0	566.7	566.7	0.38	0.38

Filter Section

Physical				
Type	Quantity / Size	Face Area	Face Velocity	Air Pressure Drop
2" ONLY RACK - with MERV13 factory filters. Is NOT a combo rack.	9 / 18 in x 24 in x 2 in	27.0 ft ²	251.9 ft/min	0.13

DX Cooling Coil

Physical

Coil Type	Refrigerant Type	Fins per Inch	Rows	Face Area	Face Velocity	Air Pressure drop	Drain Pan Material	UV Light
Cu Tube/ Al Fin	R32	15	4	19.7 ft ²	359.8 ft/min	0.28 inH ₂ O	Stainless Steel	None

Cooling Performance

Capacity			Indoor Air Temperature					Ambient air Temperature °F
Total Btu/hr	Sensible Btu/hr	Moisture Removal lb/h	Entering		Leaving			
			Dry Bulb °F	Wet Bulb °F	Dry Bulb °F	Wet Bulb °F	Dewpoint °F	
199161	169782	26.4	75.7	62.6	52.0	52.0	52.0	95.0

Condensate Connection Size: 3/4 in. Male NPT

Heating Performance

Total Capacity Btu/hr	Refrigerant Type	Indoor Air Temperature Dry Bulb		Ambient Air Temperature °F
		Entering °F	Leaving °F	
72655	R32	64.5	74.3	-4.0

Hot Gas Reheat Coil Section

Type	Face Area	Air Pressure Drop	Total Capacity	Leaving Air Temperature	
				Dry Bulb	Wet Bulb
Aluminum Tube Micro-Channel	18.9 ft ²	0.11 inH ₂ O	133067 Btu/hr	70.0 °F	58.9 °F

Fan Section

Fan				
Type	Fan Wheel Diameter	Fan Isolation		
SWSI AF	24 in	Spring Isolation		
Performance				
Airflow	Total Static Pressure	Fan Speed	Brake Horsepower	Altitude
6800 CFM	5.2 inH ₂ O	1711 rpm	8.78 HP	0 ft
Motor				Drive
Type	Horsepower	Efficiency	FLA	Type
Premium Eff Induction Motor	10.0	Premium	10.0 A	Direct Drive

Hot Water Heat Section

Physical					
Fins per Inch	Sweat Connection	Number of Rows	Face Area	Face Velocity	Air Pressure Drop
12	1.625 in	2	12.5 ft ²	544.0 ft/min	0.40 inH ₂ O
Performance					
Total Capacity Btu/hr	Temperature				
	Entering		Leaving		
	Air Dry Bulb °F	Fluid °F	Air Dry Bulb °F	Fluid °F	
181886	30.0	170.0	54.5	137.4	
Type	Glycol Concentration %	Flow Rate gpm	ft H ₂ O		
Propylene Glycol	40.0	12.0	0.1		

Unit Discharge Conditions

Air Temperature				
Motor Heat Btu/hr	Moisture Removal lb/h	Unit Leaving Dry Bulb °F	Unit Leaving Wet Bulb °F	Unit Leaving Dewpoint °F
24896	26.4	55.4	53.1	52.0
Minimum Airflows				
Notes:	Refer to fan curve for applicability of approximate airflows			

Condensing Section

Compressor						
Type	Quantity	Refrigerant Charge lb	Total Power	Capacity Control	Compressor Isolation	
Inverter Scroll	1	34.9	14.51 kW	Mod Control with Inverter Compressor	Rubber in Shear	
Compressor Amps:						
Compressor 1			17.7 A			
Condenser Coil						
Type	Fins per Inch			Fin Material		
Copper Tube - Aluminum Fin	23			Aluminum		
Condenser Fan Motors						
Number of Motors			Full Load Current (Total)			
2			6.4 A			
AHRI 340/360 Certified Data at AHRI 340/360 Standard Conditions						
Net Capacity	EER	IEER	Heat Net Capacity at 47°F	COP at 47°F	Heat Net Capacity at 17°F	COP at 17°F
194000 Btu/hr	11.0	21.2	188000 Btu/hr	3.3	124000 Btu/hr	2.4

Internal Pressure Drop Calculation

External Static Pressure:	2.00 inH ₂ O
Filter:	0.13 inH ₂ O
Outside Air:	0.23 inH ₂ O
DX Coil:	0.28 inH ₂ O
Hot Gas Reheat:	0.11 inH ₂ O
Hot Water Heat:	0.40 inH ₂ O
Total Static Pressure:	5.15 inH ₂ O

Sound

Frequency	Sound Power (db)							
	63 Hz	125 Hz	250 Hz	500 Hz	1 kHz	2 kHz	4 kHz	8 kHz
Inlet	81	80	88	80	75	74	69	66
Discharge	87	86	91	86	84	81	76	71
Radiated	80	74	76	76	76	75	75	66

Options

Electrical	
Field Connection:	Single Disconnect
Controls	
Communication Card:	BACnet IP

Factory Installed Sensors

Leaving Coil/Entering Fan Temperature Sensor
Duct High Limit Switch
Return Air Temperature Sensor
Discharge Air Temperature sensor – Wired in unit, mounted in supply duct
Outside Air Temperature Sensor
Dirty Filter On/Off Switch
Supply Fan Air Proving Via Modbus
Building Static Pressure Sensor
Supply Leaving Wheel Temperature Sensor
Exhaust Leaving Wheel Temperature Sensor
Return Air Relative Humidity Sensor
Energy Wheel VFD

Warranty

Parts: Standard One Year

Compressor: Standard One Year

Specials

Unit

Specials Description:

Notes

Unit is to be lifted with proper rigging practices outlined in IOM. Forklifting the unit is not allowed.

Daikin Fan Selection

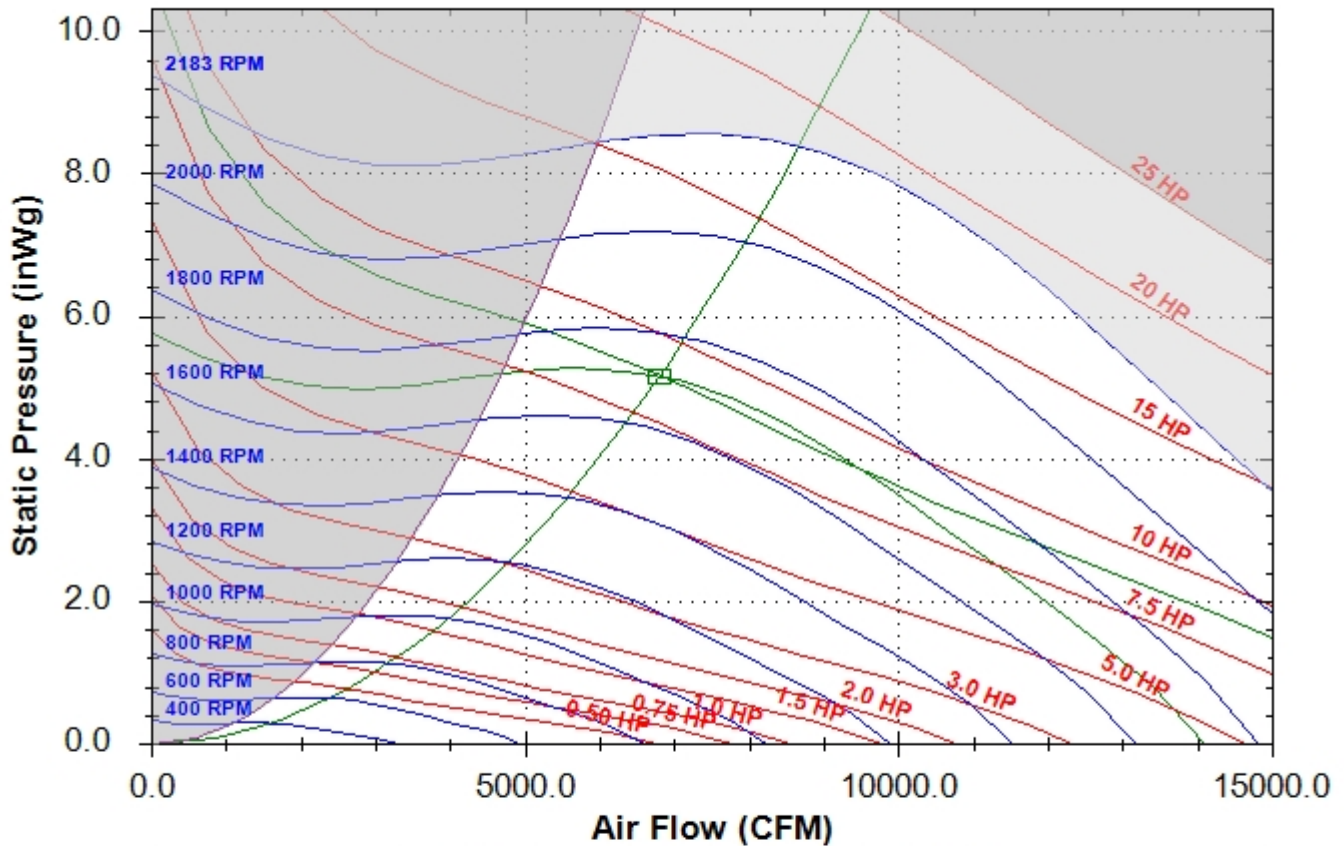

24.0 SWSI - Plenum Supply Fan at Standard Conditions								
Base Tag	RTU-2 50% ODA				Date	Apr-01-2026		
Job Name	22600705 - DCDSB Archbishop Denni...				Time	9:21 PM		
Air Volume	6800	CFM		Fan Speed	1711	RPM		
Total Static	5.15	inWg		Max Speed	2183	RPM		
Brake Horsepower	8.78	HP		Efficiency	63	%		
Unit Sound Power		63hz	125hz	250hz	500hz	1000hz	2000hz	4000hz
Inlet Sound Power		81	80	88	80	75	74	69
Outlet Sound Power		87	86	91	86	84	81	76
Radiated Sound Power		80	74	76	76	77	75	75

Daikin Fan Selection

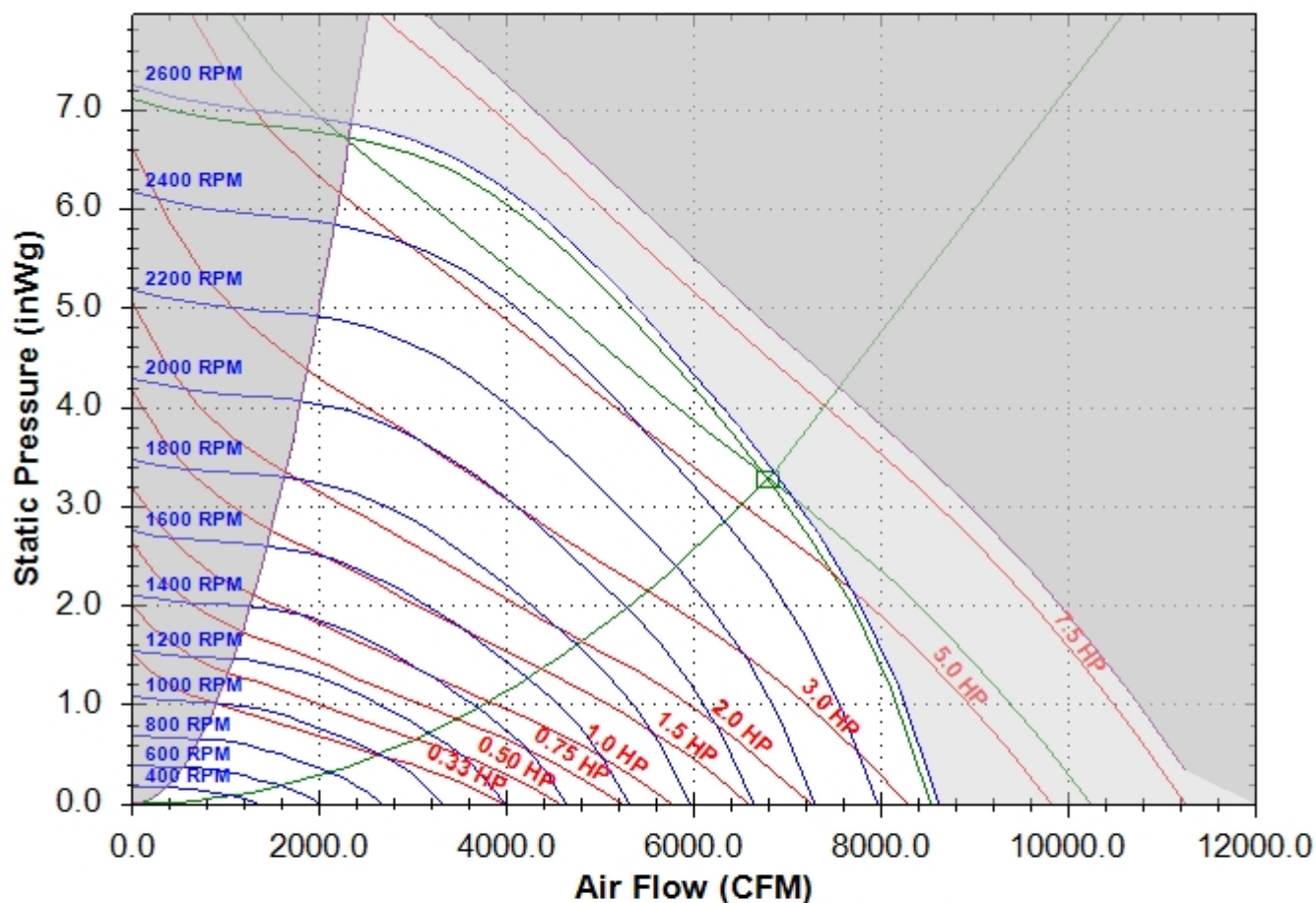

18.0 SWSI AF Exhaust Fan at Standard Conditions			
Base Tag	RTU-2 50% ODA	Date	Apr-01-2026
Job Name	22600705 - DCDSB Archbishop Denni...	Time	9:21 PM
Air Volume	6800 CFM	Fan Speed	2574 RPM
Total Static	3.3 inWg	Max Speed	2600 RPM
Brake Horsepower	5.65 HP	Efficiency	62 %
			

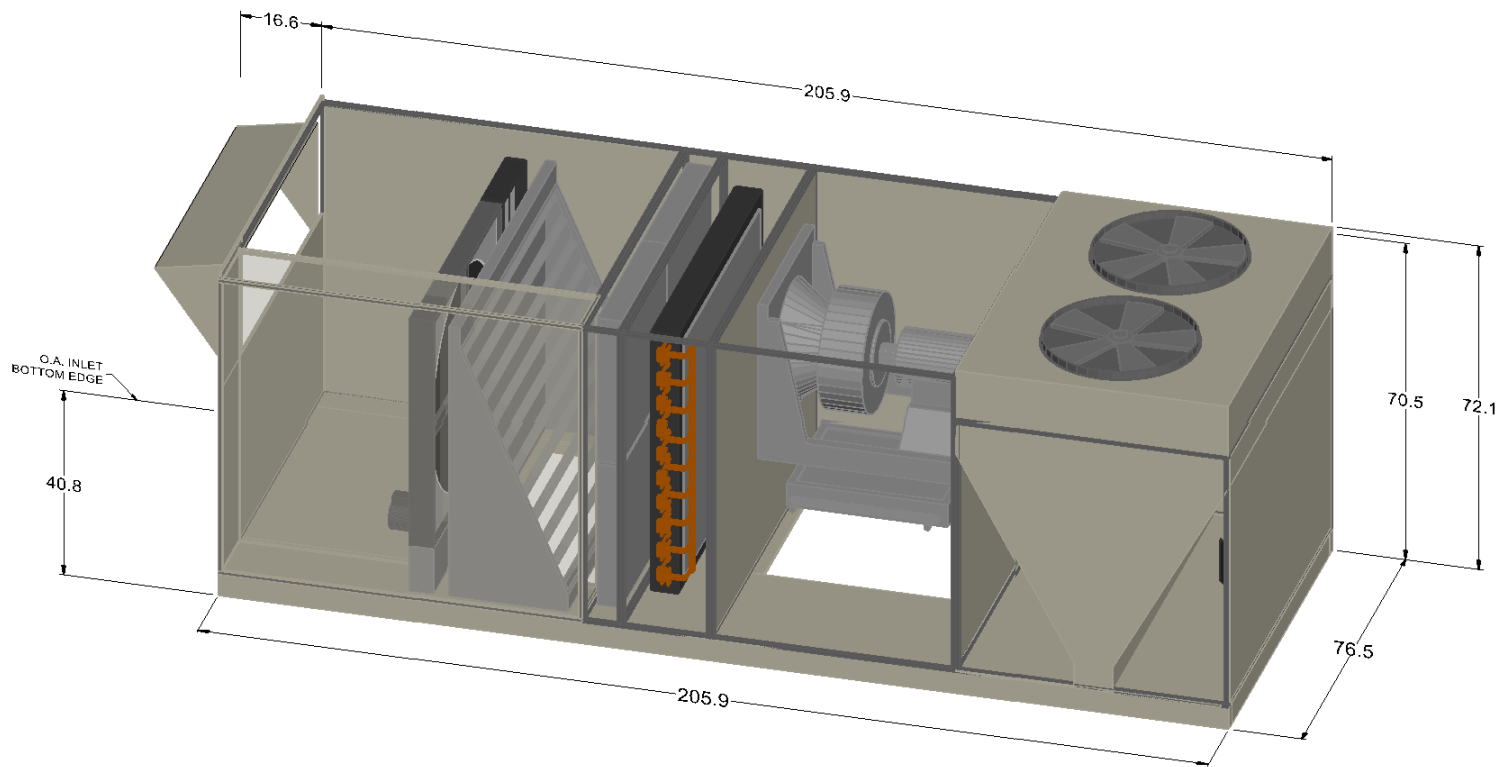

Notes:

(1) Recommended location for optional field cut side power connection.

	Unit Tag: RTU-2 50% ODA			Sales Office: HTS Engineering Ltd.			 13600 Industrial Park Blvd. Minneapolis, MN 55441 www.DaikinApplied.com Software Version: 14.10
Product: Rebel	Project Name: 22600705 - DCDSB Archbishop			Sales Engineer:			
Model: DPSH16B	Apr. 01, 2026	Ver/Rev:	Sheet: 1 of 1	Scale: NTS	Tolerance: +/- 0.25"	Dwg Units: in [mm]	
No change to this drawing may be made unless approved in writing by Daikin Applied. Purchaser must determine that the equipment is fit and sufficient for the job specifications.							

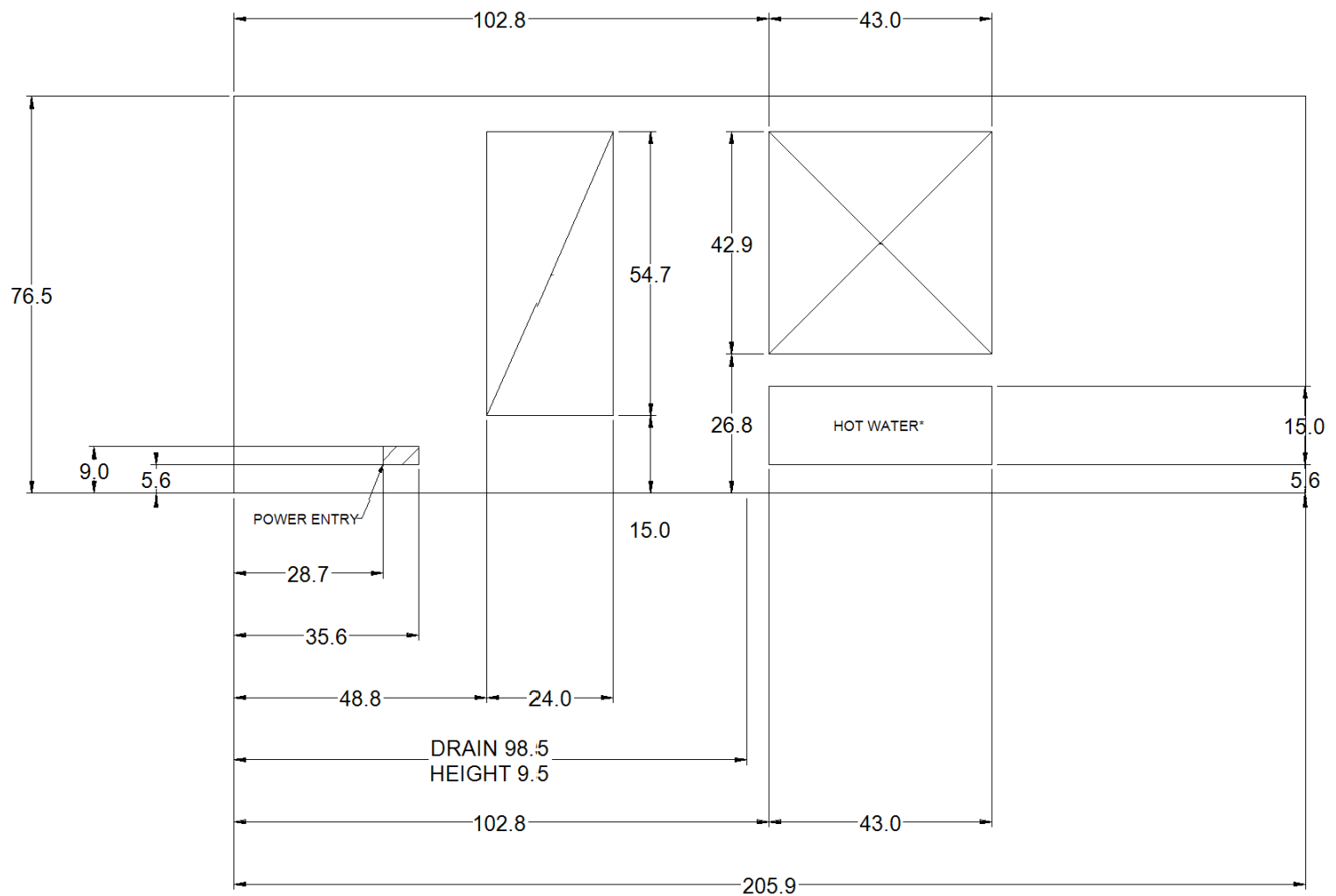

*Marked area represents available space for field to penetrate cabinet. Area marked is a solid panel ready for field cut.

PLAN VIEW - OPENINGS & OVERALL

Unit Tag: RTU-2 50% ODA		Sales Office: HTS Engineering Ltd.		 13600 Industrial Park Blvd. Minneapolis, MN 55441 www.DaikinApplied.com Software Version: 14.10		
Product: Rebel		Sales Engineer:				
Model: DPSH16B	Apr. 01, 2026	Ver/Rev:	Sheet: 1 of 1	Scale: NTS	Tolerance: +/- 0.25"	Dwg Units: in [mm]
No change to this drawing may be made unless approved in writing by Daikin Applied. Purchaser must determine that the equipment is fit and sufficient for the job specifications.						

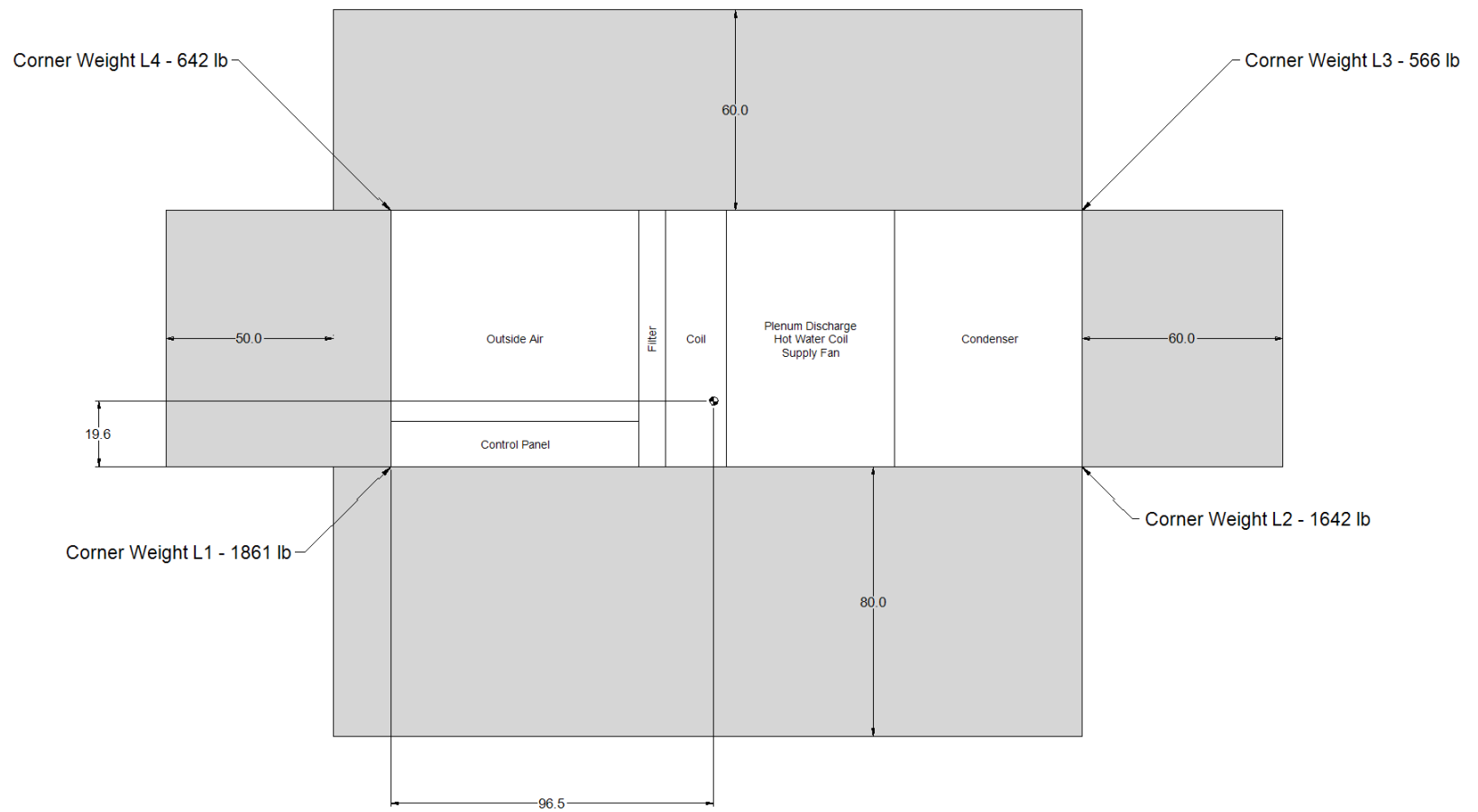

PLAN VIEW - CG, CORNER WEIGHTS, SERVICE CLEARANCE

Notes:

- (1) Center of Gravity Height = 25.6
- (2) Total Weight = 4711 lb

	Unit Tag: RTU-2 50% ODA			Sales Office: HTS Engineering Ltd.			 13600 Industrial Park Blvd. Minneapolis, MN 55441 www.DaikinApplied.com Software Version: 14.10
Product: Rebel	Project Name: 22600705 - DCDSB Archbishop			Sales Engineer:			
Model: DPSH16B	Apr. 01, 2026	Ver/Rev:	Sheet: 1 of 1	Scale: NTS	Tolerance: +/- 0.25"	Dwg Units: in [mm]	
No change to this drawing may be made unless approved in writing by Daikin Applied. Purchaser must determine that the equipment is fit and sufficient for the job specifications.							

Job Information	Technical Data Sheet
-----------------	----------------------

Job Name	22600705 - DCDSB Archbishop Dennis Oconnor
Date	4/1/2026
Submitted By	Terry Loyala
Software Version	14.10
Unit Tag	RTU-3 50% ODA



Unit Overview						
---------------	--	--	--	--	--	--

Model Number	Cabinet	Voltage V/Hz/Phase	Design Cooling Capacity Btu/hr	AHRI 340/360 Standard Efficiency		ASHRAE 90.1-2022 Compliant
				EER	IEER	
DPSH25B	C	575/60/3	279459	10.5	19.1	ASHRAE 90.1-2022 compliant

Unit	
------	--

Model Number:	DPSH25B
Model Type:	Heat Pump
Heat Type:	Hot Water
Hot Gas Reheat:	MHGRH
Energy Recovery:	ERW-Large Cab-Econ: 5145cfm max, 100% OA: 8820 cfm max
Application:	Variable Air Volume, Single Zone (Mixed Air or 100% OA)
Controls:	Microtech
Outside Air:	0-100% Economizer with Drybulb Control
Altitude:	0 ft
Approval	cETLus

Physical			
----------	--	--	--

Dimensions and Weight			
Length	Height	Width	Weight
222.5 in	72.1 in	76.5 in	5149 lb
Corner Weights			
L1	L2	L3	L4
1835 lb	1878 lb	726 lb	709 lb
Construction			
Exterior	Insulation and Liners	Air Opening Location	
		Return	Supply
Painted Galvanized Steel	2" Injected Foam, R13, Galvanized Steel Liner	Bottom	Bottom

Electrical			
------------	--	--	--

Unit FLA	MCA	MROPD	SCCR
55.8 A	60.0 A	70 A	10 kAIC
Note:	Use only copper supply wires with ampacity based on 75° C conductor rating. Connections to terminals must be made with copper lugs and copper wire.		

Return/Outside/Exhaust Air

Outside Air Option			
Type	Damper Pressure Drop	Exhaust Air Type	
90.1 and California Title 24 Compliant Economizer	0.41 inH ₂ O	Airfoil Power Exhaust Fan	
Type	Drive Type	Wheel Diameter	Fan Series
SWSI AF	Direct Drive	22 in	Series II
Motor			
(Qty) Horsepower	Type	Efficiency	Full Load Current (Each)
(1) 6.1 HP	ECM - Series I	Premium	5.0 A
Performance			
Air Flow CFM	External Static Pressure inH ₂ O	Fan Speed RPM	Brake Horsepower HP
9200	1.00	1760	5.23

Energy Recovery

Design OA Volume	Design Exhaust Volume	Wheel Pressure Drop	Motor HP	Motor FLA						
4600 CFM	3000 CFM	1.21 inH ₂ O	0.17 HP	0.9 A						
Summer Conditions										
Temperature								Recovered Capacity Btu/hr	Effectiveness	
Outside Air		Return Air		Wheel Leaving		Mixed Air			Total	Sensible
Dry Bulb °F	Wet Bulb °F	Dry Bulb °F	Wet Bulb °F	Dry Bulb °F	Wet Bulb °F	Dry Bulb °F	Wet Bulb °F			
95.0	75.0	75.0	62.0	85.3	69.3	80.1	65.8	101214	0.70	0.72
Winter Conditions										
Temperature								Recovered Capacity Btu/hr	Effectiveness	
Outside Air		Return Air		Wheel Leaving		Mixed Air			Total	Sensible
Dry Bulb °F	Wet Bulb °F	Dry Bulb °F	Wet Bulb °F	Dry Bulb °F	Wet Bulb °F	Dry Bulb °F	Wet Bulb °F			
-4.0	-5.0	72.0	54.0	30.1	26.6	51.0	41.8	226889	0.73	0.73
Bypass Damper:		Yes								
Energy Recovery Filters										
Efficiency	Quantity/Size				Face Area		Face Velocity		Air Pressure Drop	
	Outdoor	Exhaust	Outdoor	Exhaust	Outdoor ft ²	Exhaust ft ²	Outdoor ft/min	Exhaust ft/min	Outdoor inH ₂ O	Exhaust inH ₂ O
2 in. MERV 8	(2) 18 in. X 24 in.	(2) 18 in. X 24 in.			6.0	6.0	766.7	500.0	0.69	0.30

Filter Section

Physical				
Type	Quantity / Size	Face Area	Face Velocity	Air Pressure Drop
2" ONLY RACK - with MERV13 factory filters. Is NOT a combo rack.	9 / 18 in x 24 in x 2 in	27.0 ft ²	340.7 ft/min	0.19

DX Cooling Coil

Physical

Coil Type	Refrigerant Type	Fins per Inch	Rows	Face Area	Face Velocity	Air Pressure drop	Drain Pan Material	UV Light
Cu Tube/ Al Fin	R32	15	4	22.4 ft ²	429.9 ft/min	0.37 inH ₂ O	Stainless Steel	None

Cooling Performance

Capacity			Indoor Air Temperature					Ambient air Temperature °F
Total Btu/hr	Sensible Btu/hr	Moisture Removal lb/h	Entering		Leaving			
			Dry Bulb °F	Wet Bulb °F	Dry Bulb °F	Wet Bulb °F	Dewpoint °F	
279459	236345	37.2	80.1	65.8	55.5	55.5	55.5	95.0

Condensate Connection Size: 3/4 in. Male NPT

Heating Performance

Total Capacity Btu/hr	Refrigerant Type	Indoor Air Temperature Dry Bulb		Ambient Air Temperature °F
		Entering °F	Leaving °F	
252930	R32	70.0	95.3	47.0

Hot Gas Reheat Coil Section

Type	Face Area	Air Pressure Drop	Total Capacity	Leaving Air Temperature	
				Dry Bulb	Wet Bulb
Aluminum Tube Micro-Channel	21.6 ft ²	0.10 inH ₂ O	145111 Btu/hr	70.0 °F	60.8 °F

Fan Section

Fan				
Type	Fan Wheel Diameter	Fan Isolation		
SWSI AF	24 in	Spring Isolation		
Performance				
Airflow	Total Static Pressure	Fan Speed	Brake Horsepower	Altitude
9200 CFM	4.9 inH ₂ O	1810 rpm	10.75 HP	0 ft
Motor				Drive
Type	Horsepower	Efficiency	FLA	Type
Premium Eff Induction Motor	15.0	Premium	13.6 A	Direct Drive

Hot Water Heat Section

Physical					
Fins per Inch	Sweat Connection	Number of Rows	Face Area	Face Velocity	Air Pressure Drop
12	1.625 in	2	12.5 ft ²	736.0 ft/min	0.67 inH ₂ O
Performance					
Total Capacity Btu/hr	Temperature				
	Entering		Leaving		
	Air Dry Bulb °F	Fluid °F	Air Dry Bulb °F	Fluid °F	
246170	34.0	170.0	58.5	136.8	
Type	Glycol Concentration %	Flow Rate gpm	ft H ₂ O		
Propylene Glycol	40.0	16.0	0.3		

Unit Discharge Conditions

Air Temperature				
Motor Heat Btu/hr	Moisture Removal lb/h	Unit Leaving Dry Bulb °F	Unit Leaving Wet Bulb °F	Unit Leaving Dewpoint °F
31181	37.2	58.6	56.5	55.5
Minimum Airflows				
Notes:	Refer to fan curve for applicability of approximate airflows			

Condensing Section

Compressor						
Type	Quantity	Refrigerant Charge lb	Total Power	Capacity Control	Compressor Isolation	
Inverter Scroll	2	46.0	21.01 kW	Mod Control with Inverter Compressor	Rubber in Shear	
Compressor Amps:						
Compressor 1			17.0 A			
Compressor 2			12.0 A			
Condenser Coil						
Type	Fins per Inch			Fin Material		
Copper Tube - Aluminum Fin	23			Aluminum		
Condenser Fan Motors						
Number of Motors			Full Load Current (Total)			
2			6.4 A			
AHRI 210/240 Certified Data at AHRI 210/240 Standard Conditions						
Net Capacity	EER	SEER2	Heat Net Capacity at 47°F	COP at 47°F	HSPF2	
270000 Btu/hr	10.5	0	248000 Btu/hr	3.30	0.0	
AHRI 340/360 Certified Data at AHRI 340/360 Standard Conditions						
Net Capacity	EER	IEER	Heat Net Capacity at 47°F	COP at 47°F	Heat Net Capacity at 17°F	COP at 17°F
270000 Btu/hr	10.5	19.1	248000 Btu/hr	3.3	170000 Btu/hr	2.05
AHRI 210/240 Certified Data at AHRI 210/240 Standard Conditions						
Net Capacity	EER	IEER	Heat Net Capacity at 47°F	COP at 47°F	Heat Net Capacity at 17°F	COP at 17°F
270000 Btu/hr	10.5	19.1	248000 Btu/hr	3.3	170000 Btu/hr	2.05

Internal Pressure Drop Calculation

External Static Pressure:	1.25 inH ₂ O
Filter:	0.19 inH ₂ O
Outside Air:	0.41 inH ₂ O
Energy Recovery:	1.90 inH ₂ O
DX Coil:	0.37 inH ₂ O
Hot Gas Reheat:	0.10 inH ₂ O
Hot Water Heat:	0.67 inH ₂ O
Total Static Pressure:	4.89 inH₂O

Sound

Frequency	Sound Power (db)							
	63 Hz	125 Hz	250 Hz	500 Hz	1 kHz	2 kHz	4 kHz	8 kHz
Inlet	80	79	87	79	74	73	68	65
Discharge	86	85	90	85	83	80	75	70
Radiated	80	74	76	76	78	76	76	67

Options

Electrical	
Field Connection:	Single Disconnect
Controls	
Communication Card:	BACnet IP

Factory Installed Sensors

Leaving Coil/Entering Fan Temperature Sensor
Duct High Limit Switch
Return Air Temperature Sensor
Discharge Air Temperature sensor – Wired in unit, mounted in supply duct
Outside Air Temperature Sensor
Dirty Filter On/Off Switch
Supply Fan Air Proving Via Modbus
Building Static Pressure Sensor
Supply Leaving Wheel Temperature Sensor
Exhaust Leaving Wheel Temperature Sensor
Return Air Relative Humidity Sensor
Energy Wheel VFD

Warranty

Parts: Standard One Year

Compressor: Standard One Year

Specials

Unit

Specials Description:

Notes

Unit is to be lifted with proper rigging practices outlined in IOM. Forklifting the unit is not allowed.

Daikin Fan Selection

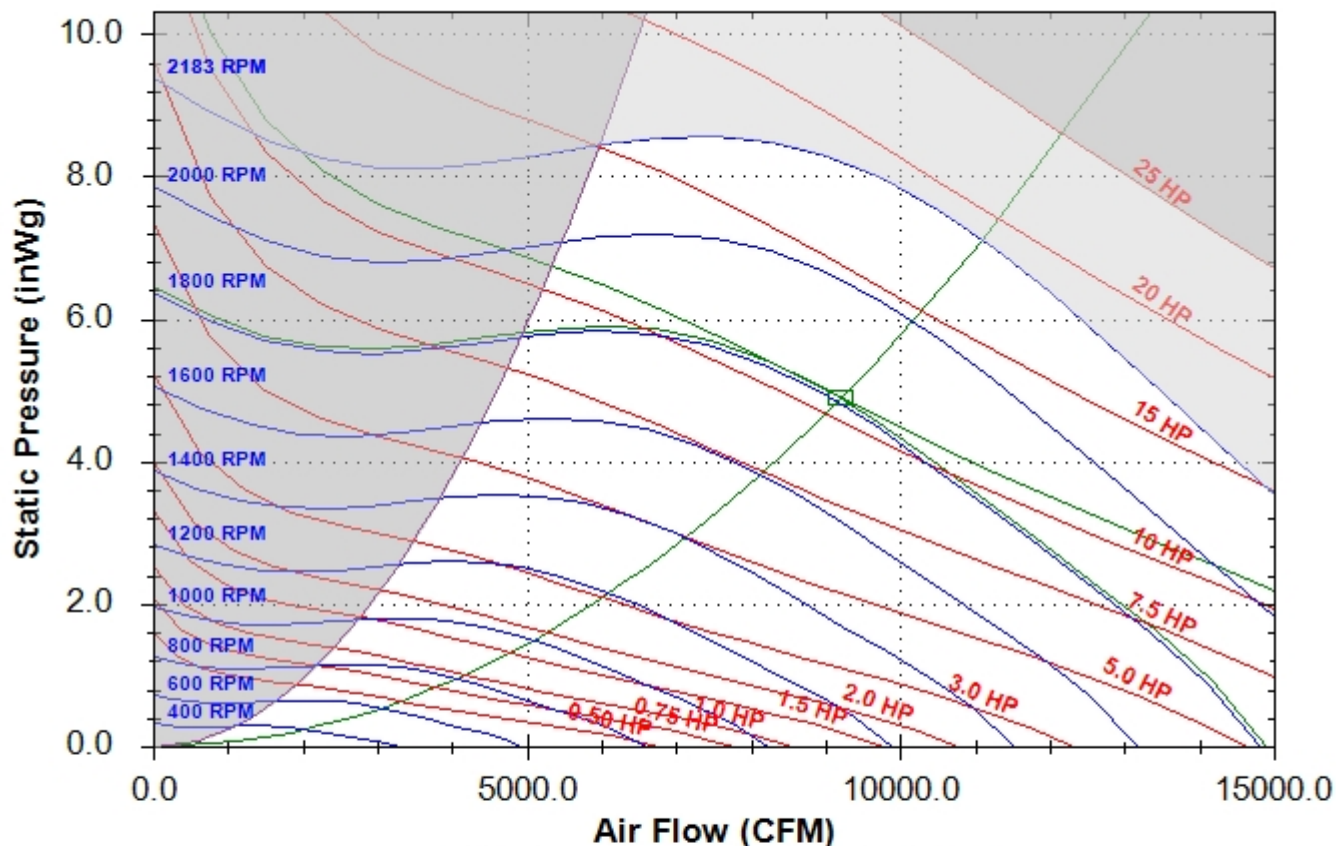

24.0 SWSI - Plenum Supply Fan at Standard Conditions								
Base Tag	RTU-3 50% ODA				Date	Apr-01-2026		
Job Name	22600705 - DCDSB Archbishop Denni...				Time	9:21 PM		
Air Volume	9200	CFM		Fan Speed	1810	RPM		
Total Static	4.89	inWg		Max Speed	2183	RPM		
Brake Horsepower	10.75	HP		Efficiency	66	%		
Unit Sound Power	63hz	125hz	250hz	500hz	1000hz	2000hz	4000hz	8000hz
Inlet Sound Power	80	79	87	79	74	73	68	65
Outlet Sound Power	86	85	90	85	83	80	75	70
Radiated Sound Power	80	74	76	76	78	76	76	67



Daikin Fan Selection

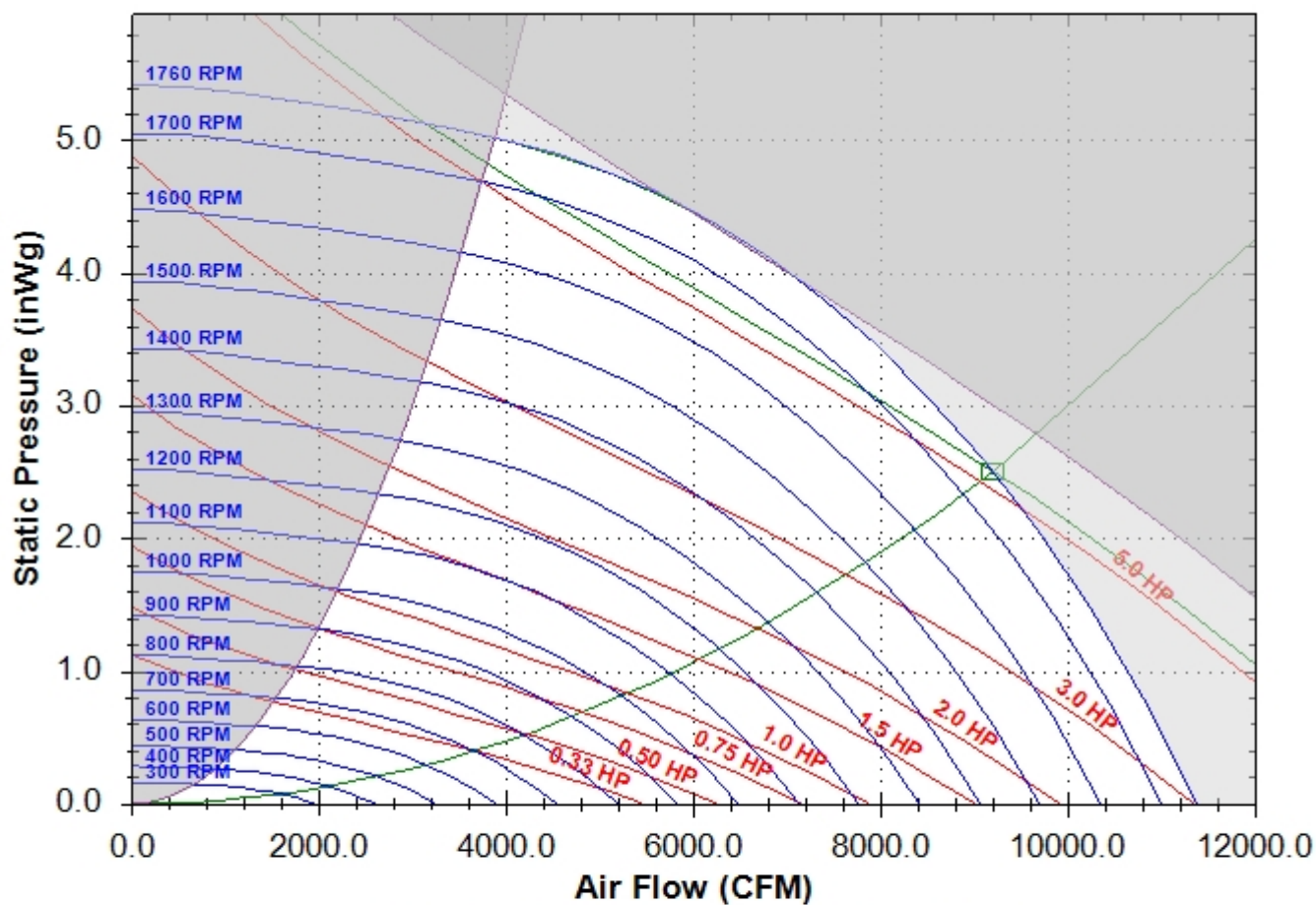

22.0 SWSI - Plenum Exhaust Fan at Standard Conditions			
Base Tag	RTU-3 50% ODA	Date	Apr-01-2026
Job Name	22600705 - DCDSB Archbishop Denni...	Time	9:21 PM
Air Volume	9200 CFM	Fan Speed	1760 RPM
Total Static	2.5 inWg	Max Speed	1760 RPM
Brake Horsepower	5.23 HP	Efficiency	69 %
			

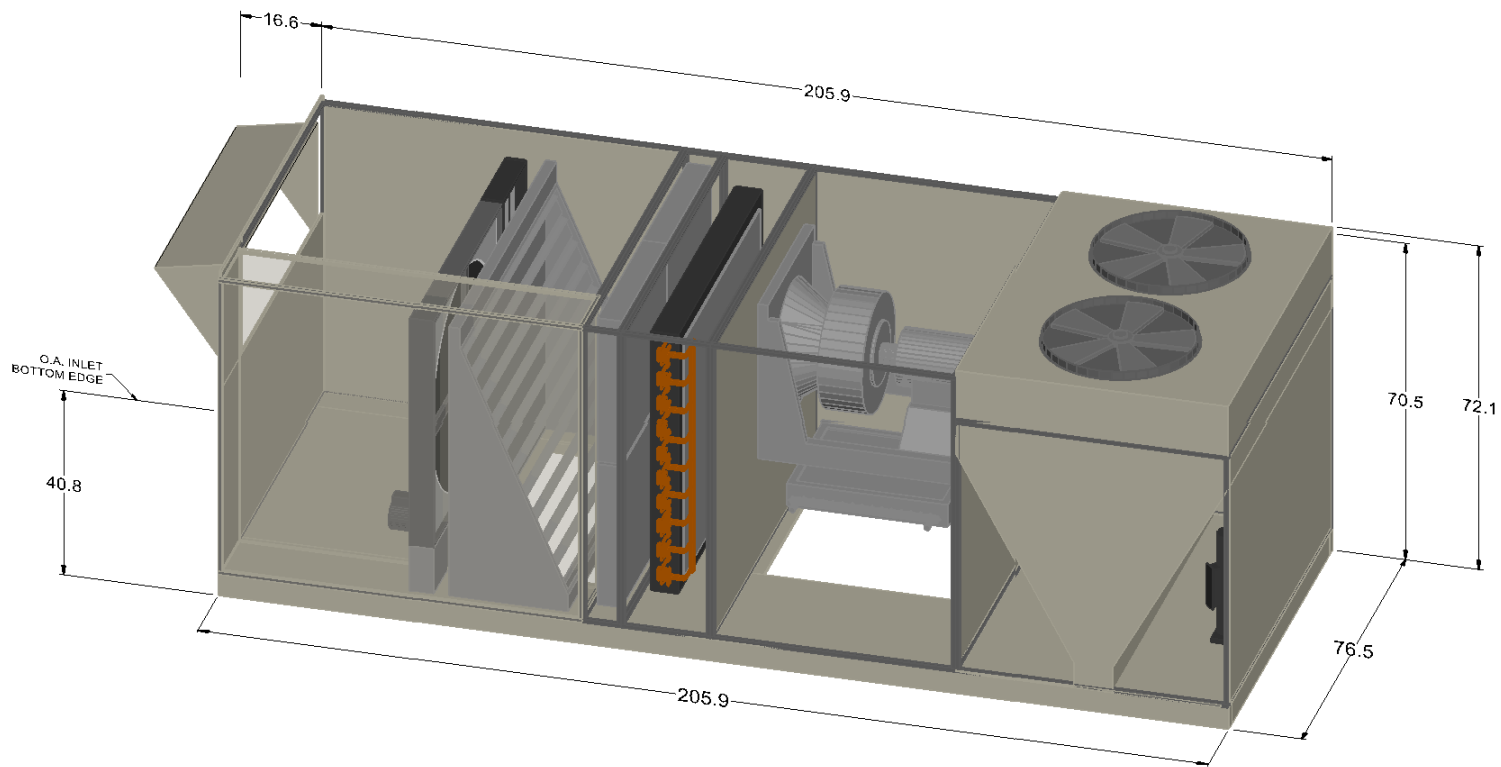

Notes:

(1) Recommended location for optional field cut side power connection.

	Unit Tag: RTU-3 50% ODA			Sales Office: HTS Engineering Ltd.			 13600 Industrial Park Blvd. Minneapolis, MN 55441 www.DaikinApplied.com Software Version: 14.10
Product: Rebel	Project Name: 22600705 - DCDSB Archbishop			Sales Engineer:			
Model: DPSH25B	Apr. 01, 2026	Ver/Rev:	Sheet: 1 of 1	Scale: NTS	Tolerance: +/- 0.25"	Dwg Units: in [mm]	
No change to this drawing may be made unless approved in writing by Daikin Applied. Purchaser must determine that the equipment is fit and sufficient for the job specifications.							

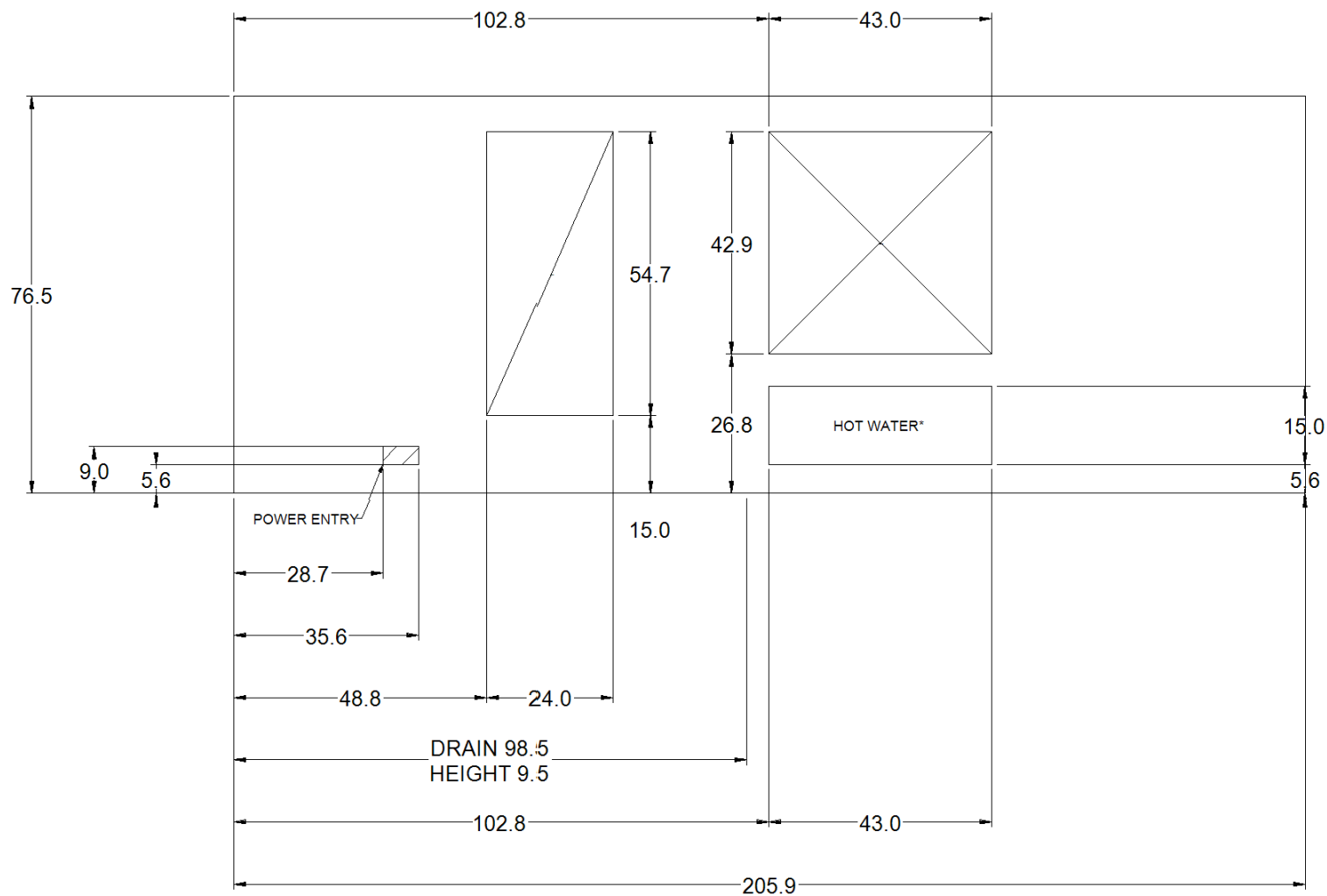

*Marked area represents available space for field to penetrate cabinet. Area marked is a solid panel ready for field cut.

PLAN VIEW - OPENINGS & OVERALL

Unit Tag: RTU-3 50% ODA		Sales Office: HTS Engineering Ltd.		 13600 Industrial Park Blvd. Minneapolis, MN 55441 www.DaikinApplied.com Software Version: 14.10		
Product: Rebel	Project Name: 22600705 - DCDSB Archbishop	Sales Engineer:				
Model: DPSH25B	Apr. 01, 2026	Ver/Rev:	Sheet: 1 of 1	Scale: NTS	Tolerance: +/- 0.25"	Dwg Units: in [mm]
No change to this drawing may be made unless approved in writing by Daikin Applied. Purchaser must determine that the equipment is fit and sufficient for the job specifications.						

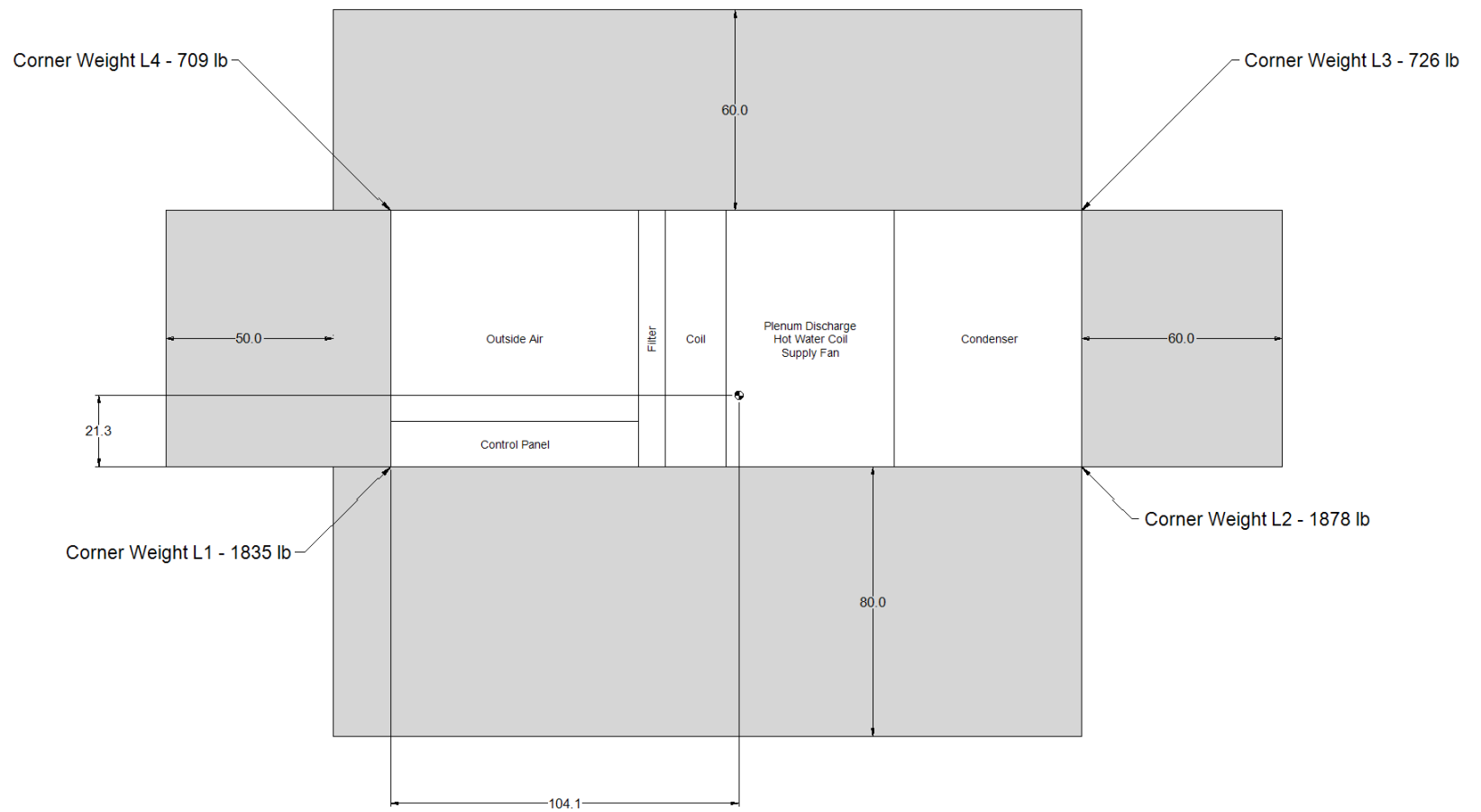

PLAN VIEW - CG, CORNER WEIGHTS, SERVICE CLEARANCE

Notes:

- (1) Center of Gravity Height = 25.2
- (2) Total Weight = 5149 lb

	Unit Tag: RTU-3 50% ODA			Sales Office: HTS Engineering Ltd.			 13600 Industrial Park Blvd. Minneapolis, MN 55441 www.DaikinApplied.com Software Version: 14.10
Product: Rebel	Project Name: 22600705 - DCDSB Archbishop			Sales Engineer:			
Model: DPSH25B	Apr. 01, 2026	Ver/Rev:	Sheet: 1 of 1	Scale: NTS	Tolerance: +/- 0.25"	Dwg Units: in [mm]	
No change to this drawing may be made unless approved in writing by Daikin Applied. Purchaser must determine that the equipment is fit and sufficient for the job specifications.							



HTS Oshawa

2001 Thickson Rd, South
Unit #11
Whitby, ON L1N 6J3
T 905.579.6700
F 905.597.5290

ontario.htseng.com

SUBMITTAL DATA
APPROVAL REQUIRED

IOM LINK

https://htseng-my.sharepoint.com/:f:/g/personal/curtis_metrow_hts_com/IgD_JwPmhDmwQZINhdRqf-csAWEu08nbwsg2MnbpeWdmLds?e=AVpGVC

Submittal # 98345

APPROVAL REQUIRED

Project 22600705-OWN-1- DCDSB - Archbishop Denis O'Connor
Leader Curtis Metrow
Job Site 80 Mandrake St, Ajax, ON, Canada
Submission Date 2026-04-01
Sold To DURHAM CDSB *
Submitted By Curtis Metrow

Contacts

Role	Customer	Our Rep
Owner	Durham Catholic District School Board *	Curtis Metrow
Designer	Ellard Willson Engineering	Steve Cukrovani



Deliverables

Track #	335945	335948	
Tag	AHU-1	AHU-2	
Description	CAH- Indoor Vision Air Handling	CAH- Indoor Vision Air Handling	
Quantity	1	1	
Manufacturer	Daikin Applied	Daikin Applied	
Specification			
Production Lead Time	10 - 12 Weeks	10 - 12 Weeks	
Revision #	1	1	

Attention:

- 1) HTS will provide equipment in accordance with the attached shop drawings.
- 2) Upon approved submittal and customer release, HTS will release equipment to fabrication per the published lead times. Any storage fees associated with project schedule changes will be the responsibility of the purchaser.
- 3) HTS can provide freight and logistics to the purchaser as an added benefit of doing business with HTS. When freight is received by the purchaser, any noticeable damage must be recorded. Otherwise, HTS is not responsible for subsequent damage claims.

Approval Stamps

<p>RYBKA ELLARD WILLSON INC</p> <p><input type="checkbox"/> REVIEWED</p> <p><input checked="" type="checkbox"/> REVIEWED AS NOTED</p> <p><input type="checkbox"/> REVISE AND RESUBMIT</p> <hr/> <p>SUBMITTAL WAS REVIEWED FOR DESIGN CONFORMITY AND GENERAL CONFORMANCE TO CONTRACT DOCUMENTS ONLY. THE CONTRACTOR IS RESPONSIBLE FOR CONFIRMING AND CORRELATING DIMENSIONS AT JOB SITES FOR TOLERANCES, CLEARANCES, QUANTITIES, FABRICATION PROCESSES AND TECHNIQUES OF CONSTRUCTION, COORDINATION OF THEIR WORK WITH OTHER TRADES AND FULL COMPLIANCE WITH THE CONTRACT DOCUMENTS.</p> <hr/> <p>BY JMACQUARRIE DATE 2026/4/6</p>		<p>RYBKA ELLARD WILLSON INC</p> <p><input checked="" type="checkbox"/> REVIEWED</p> <p><input type="checkbox"/> REVIEWED AS NOTED</p> <p><input type="checkbox"/> REVISE AND RESUBMIT</p> <hr/> <p>SUBMITTAL WAS REVIEWED FOR DESIGN CONFORMITY AND GENERAL CONFORMANCE TO CONTRACT DOCUMENTS ONLY. THE CONTRACTOR IS RESPONSIBLE FOR CONFIRMING AND CORRELATING DIMENSIONS AT JOB SITES FOR TOLERANCES, CLEARANCES, QUANTITIES, FABRICATION PROCESSES AND TECHNIQUES OF CONSTRUCTION, COORDINATION OF THEIR WORK WITH OTHER TRADES AND FULL COMPLIANCE WITH THE CONTRACT DOCUMENTS.</p> <hr/> <p>BY FCHANG DATE 4/6/2026</p>	
--	---	---	---

REW COMMENTS:

- UNITS TO BE FULLY BROKEN DOWN AND SHIPPED LOOSE. ALL COMPONENTS TO FIT THROUGH A SINGLE DOOR WAY.
- REFER TO NOTES ON HANDING
- AHU-1 TO BE 50% OA
- AHU-2 TO BE 40% OA
- COOLING COIL SIZING BASED ON ENERGY RECOVERY SAVINGS
- HEATING COIL SIZING: NO ENERGY CREDIT TO BE TAKEN FROM ERV
- FAN ESP: 2" WC
- MERV 13 FILTERS
- 40% PG TEMPERATURES 170F/150F
- REFER TO NOTES ON AHU-1 RE/ DAMPERS AND MIXING BOX.



HTS Oshawa

2001 Thickson Rd, South
Unit #11
Whitby, ON L1N 6J3
T 905.579.6700
F 905.597.5290

ontario.htseng.com

SUBMITTAL DATA
APPROVAL REQUIRED

INDOOR AIR HANDLING UNIT

AHU-1,2

Technical Information And Drawings

Notes:

- 1) Electrical:
 - a. A 575/3/60 electrical feed is required per unit
 - i. AHU-1 MCA = 43.6A / MOP = 60A
 - ii. AHU-2 MCA = 10A / MOP = 15A
 - b. Main fused disconnect is provided on unit VFD
 - c. 120/1/60 electrical 15A MOP circuit required for lights found in AHU-1 mixing & plenum sections, AHU-2 fan section. Wiring between sections is by others.
- 2) Unit Information:
 - a. Supply fans with factory wired, mounted VFDs
 - b. Spring isolators on fans
 - c. Painted construction
 - d. Stainless steel drain pans in cooling coil sections
 - e. Windows on access doors with marine lights (AHU-1 mixing, plenum section, AHU-2 plenum section)
- 3) Controls
 - a. All controls by others
- 4) Assembly Info
 - a. AHU-1 ships in three pieces, assembly of unit by installing contractor
 - i. 62x132x80- 2055lbs **REW JM COMMENTS:**
 - ii. 86x132x80- 4276lbs **UNITS TO BE FULLY BROKEN DOWN TO PASS THROUGH A SINGLE DOOR.**
 - iii. 186x132x80- 798lbs
- 5) Warranty:
 - a. 2-year factory parts warranty included

Job Information		Technical Data Sheet	
Job Name	22600705 - DCDSB Archbishop Dennis Oconnor		
Date	01 April 2026		
Submitted By	Ellard Willson Engineering		
Software Version	13.94		
Unit Tag	AHU-1 50% ODA		

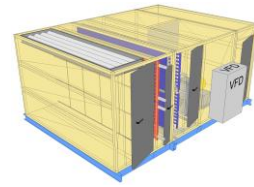

Unit Overview

Model Number	Supply					
	Air Volume cfm	Static Pressure		External Dimensions		
		External inWc	Total inWc	Height in	Width in	Length in
CAH059GDHM	29000	2.00	3.89	80*	132*	186

*Not including base rails, coil connectors, drain connectors and control boxes.

Unit

Model Number:	CAH059GDHM				
Approval:	ETL Listed / ETL Listed to Canadian Safety Standards (ETL Label / ETLc Label)				
Outer Panel:	Painted 24 gauge G60 Galvanized Steel (3000 hr. Salt Spray ASTM B-117)				
Liner:	24 gauge Galvanized Steel (unless noted per section)				
Insulation:	R-13 Injected Foam				
Unit Configuration:	Inline horizontal	Drive (Handling) Location:	Right		
Base:	6" formed channel	Wall Thickness:	2 in		
Altitude:	0 ft	Parts Warranty:	Standard One Year		

Mixing Box

Mixing Box		Component: 1		Length: 42 in		Shipping Section: 1			
Portion	Damper					Blade Action	Rated CFM	Air Pressure Drop	Quantity
	Size (Width x Height)		Location	Type	Actuation				
	Overall	Opening							
Outside Air	No opening	No opening		None		None	29000 cfm		0
Return Air	128 in x 34 in	118 in x 30 in	Top	UltraSeal Low Leak	NA	Parallel	29000 cfm	0.11 insWg	1

Filter Data							
Type	Efficiency	Nominal Face Velocity	Actual Face Velocity	Actual Face Area	Air Volume	Filter Loading	
Pre Pleat	MERV 13	439 ft/min	464 ft/min	62.5 ft ²	29000 cfm	Side	
Air Pressure Drop				Number of Filters	Height	Width	Depth
Clean Air	Mean Air	Dirty Air	User Spec				
0.32 inWc	0.66 inWc	1.00 inWc	N/A	15	24 in	24 in	2 in
				3	24 in	12 in	2 in

Door			
Location	Width	Opening	LED Light
Drive side	30 in	Outward	LED marine light kit and switch only

Hot Water Coil		Component: 2			Length: 20 in		Shipping Section: 1	
Coil Model	Total Capacity	Number of Coils	Number of Rows	Fins per Inch	Tube Diameter	Tube Spacing (Face x Row)		
5WS1002B	1749792 Btu/hr	2	2	10	0.625 in	1.50 in x 1.299 in		
Coil Operating Weight				Coil Dry Weight				
34F 448 lb				313 lb				
Air Volume	Air Temperature		Coil Air Pressure Drop	Finned Height	Finned Length	Face Area	Face Velocity	
	Entering Dry Bulb	Leaving Dry Bulb						
29000 cfm	37.0 °F	92.2 °F	0.22 inWc	33 in	116 in	53.17 ft²	545 ft/min	
Fluid								
Entering	Leaving	Flow Rate	Pressure Drop	Velocity	Fluid Volume	Fluid Weight		
170.0 °F	149.2 °F	181.00 gpm	9.20 ftHd	4.40 ft/s	16.0 gal	135.00 lb		
Connection [Data Per Coil]				Glycol Type	Min. Fin Surface Temp.	Min. Tube Wall Surface Temp.	Fouling Factor	
Type	Size	Location	Material					
Threaded	2.50 in	Drive side	Carbon steel	Propylene (40%)	149.2 °F	149.2 °F	0.000	
Material								
Fin		Tube		Header		Case		
Aluminum .0075 in		Copper .020 in		Copper		Galv. steel		
AHRI 410 Certification								
Coil is NOT certified by AHRI								
Door								
Location		Width		Opening				
Drive side		8 in		Outward				

Direct Expansion Coil		Component: 3			Length: 38 in		Shipping Section: 2		
Coil Model	Total Capacity	Sensible Capacity	Number of Coils	Number of Rows	Fins per Inch	Tube Diameter	Tube Spacing (Face x Row)		
5EJ1204C	970640 Btu/hr	661740 Btu/hr	2	4	12	0.625 in	1.50 in x 1.299 in		
Coil Operating Weight				865 lb					
Air Volume	Air Temperature				Coil Air Pressure Drop	Finned Height	Finned Length	Face Area	Face Velocity
	Entering Dry Bulb	Wet Bulb	Leaving Dry Bulb	Wet Bulb					
29000 cfm	76.0 °F	65.0 °F	55.1 °F	53.9 °F	1.12 insWg	33 in	119 in	54.54 ft²	532 ft/min
Suction Temp.	Refrigerant	Sub-Cooled Refrigerant Liquid Temp.		Suction Vapor Superheat Temp. at Coil Outlet		Design Saturated Condensing Temp.		Total Refrigerant Weight	
44.0 °F	R410a	110.0 °F		8.0 °F		110.0 °F		112.00 lb	
Connection [Data Per Coil]						Min. Fin Surface Temp.	Min. Tube Wall Surface Temp.		
Type	Liquid [Qty - Size]	Suction [Qty - Size]	Location	Material					
OD Sweat	2-1.38 in	2-1.63 in	Drive side	Copper tube		32.0 °F	32.0 °F		
Material						Drain Pan	Drain Side		
Fin	Tube	Header	Case						
Aluminum .0075 in	Copper .020 in	Copper	Galv. steel		Stainless steel Drive side				
Total Refrigerant Weight is the total for all circuits of all coils in this coil section and is estimated. Refer to the AHU and Condensing Unit IOMs for recommendations on system start-up.									
Minimum allowable face velocity = 150 fpm									
AHRI 410 Certification									
Coil is NOT certified by AHRI									
Door									
Location			Width			Opening			
Drive side			20 in			Outward			

REW JM NOTE:
 MIXED AIR TEMPS DEREIVED FROM:
 ERV: 11,000CFM,
 RETURN: 14,500CFM,
 UNTREATED O/A: 3,500CFM

REW JM NOTE:
 MIXED AIR TEMPS DEREIVED FROM:
 ERV: 0CFM,
 RETURN: 14,500CFM,
 UNTREATED O/A: 14,500CFM

Supply Fan Array	Component: 4	Length: 48 in	Shipping Section: 2
-------------------------	--------------	---------------	---------------------

Fan Performance

Air Volume*	Static Pressure			Fan Energy Index(FEI)	Total Input Power	Fan Shaft Power*	Fan Wheel Speed		Redundancy(N-1)	Fan Circuit	
	External	Total	Cabinet				Operating	Maximum		MOP	MCA
14500 cfm	2.00 inWc	3.89 inWc	0.00 inWc	1.01	27.6 kW	15.02 BHP	2077 rpm	2183 rpm	60.8 %	60.0 A	43.6 A

Fan Data

Fan Type	Blade Type / Class	Nominal Fan Size	Quantity of Fans	Wheel Diameter	Number of Blades	Discharge	Motor Location
SWSI / 1x2	Airfoil / 2	DFA24	2	24.50 in	9	Axial	Behind Fan

Motor Data

Power*	Electrical Supply	Speed	Efficiency	Enclosure	Frame Size	Supplier	Number of Poles	Lock Rotor Current*	Full Load Current*
20.0 HP	575/60/3 V/Hz/Phase	1750 rpm	Premium	ODP	256 T frame	Generic	4	118.41 A	19.30 A

Fan Options

Block Off Plate:	Provided	Isolator Type:	Spring
-------------------------	----------	-----------------------	--------

VFD/Starters/Disconnect Data

Selection Type:	1 VFD for array	Vendor:	Danfoss (FC101)
Auxiliary Control:	Disconnect	VFD Power:	50 HP
Voltage:	575 v	Disconnect Type:	Fused
Height x Width x Depth:	47.20 in x 31.50 in x 15.70 in	Mounting:	Door Side
Enclosure:	NEMA 1	VFD Quantity:	1

IS THIS CORRECT?

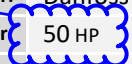

Panel

Location	Width	Opening
Removable panels	- in	Outward

Notes

* after a unit label denotes the data per fan.

Plenum Section	Component: 5	Length: 38 in	Shipping Section: 3
-----------------------	--------------	---------------	---------------------

Opening Location	Opening Size	Air Pressure Drop
Top	34.00" x 128.00"	0.12 inWc

Door

Location	Width	Opening	LED Light
Drive side	30 in	Outward	LED marine light kit and switch only

Unit Sound Power (dB)

Type	63 Hz	125 Hz	250 Hz	500 Hz	1000 Hz	2000 Hz	4000 Hz	8000 Hz
Radiated:	83	76	82	75	72	64	58	51
Unit Discharge:	88	81	91	90	88	86	90	77
Unit Return:	83	76	88	81	76	76	76	61

Shipping Section Details

Section	Length in	Weight lb	Corner Weights (lb)				Center of Gravity (in)		
			P1	P2	P3	P4	XX	YY	ZZ
1	62	2055	473	451	554	576	34	65	39
2	86	4276	1231	1060	948	1119	41	61	39
3	38	798	148	141	251	258	24	65	29
Entire Unit	186	7129	1943	1743	1662	1862	91	62	38

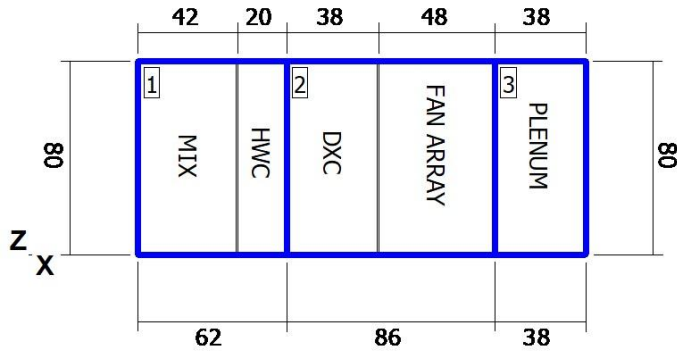

Elevation View

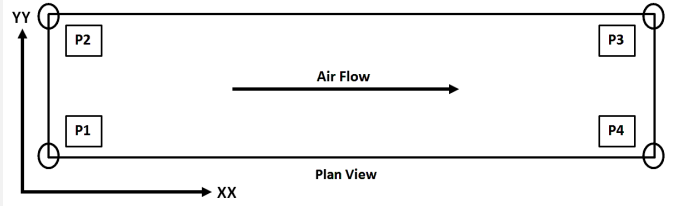

NOTE: Special components aren't included in the corner weights and center of gravity data.

NOTE: Shipping weights listed do not include weight of water (listed in coil section(s) above).

Shipping Protection

None

Supply Static Pressure Drop

Component	Option	Static Pressure Drop
Mixing Box	Filter	0.32 insWg
Mixing Box	Mixing Box	0.12 insWg
Hot Water Coil	Hot Water Coil	0.22 insWg
DX Coil	DX Coil	1.12 insWg
Supply Fan	Cabinet	
Plenum Section	Plenum Section	0.12 insWg
External Static	External Static	2.00 insWg
Total Supply Fan Static		3.89 insWg

REW JM COMMENTS:
UNITS TO BE FULLY BROKEN DOWN TO PASS THROUGH A SINGLE DOOR.

Minimum Recommended Drain Pan Trap Dimensions

Shipping Section	Component	H
2	DX Coil	4.04

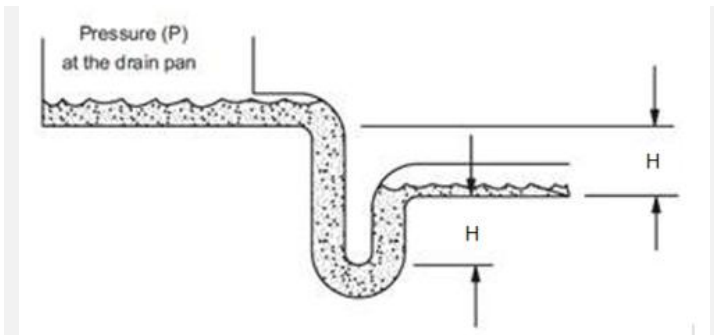

Dimensions provided as a courtesy and are recommended minimums only. Daikin is not responsible for supplying or designing drain pan traps and is not responsible for any damage caused by incorrect trap heights. The dimensions listed above should be reviewed and approved by a licensed plumbing professional.

This calculation is based on an assumption that 0.25 inches of the external static pressure is in the return duct and the remainder is in the supply duct. If actual conditions vary from this assumption then contact Applications for new trap height recommendations.

AHRI Certification



Certified by the AHRI Central Station Air-Handling Unit (AHU) Certification Program, which is based on AHRI Standard 430/431. AHRI certified units are subject to rigorous and continuous testing, have performance ratings independently measured and are third-party verified. Certified units may be found in the AHRI Directory at www.ahridirectory.org.

Notes

Standard

1. As a standalone component, unit meets or exceeds requirements of ASHRAE 90.1 - 2007. The approving authority is responsible for compliance of multi - component building systems.

Daikin AHU Fan Curve

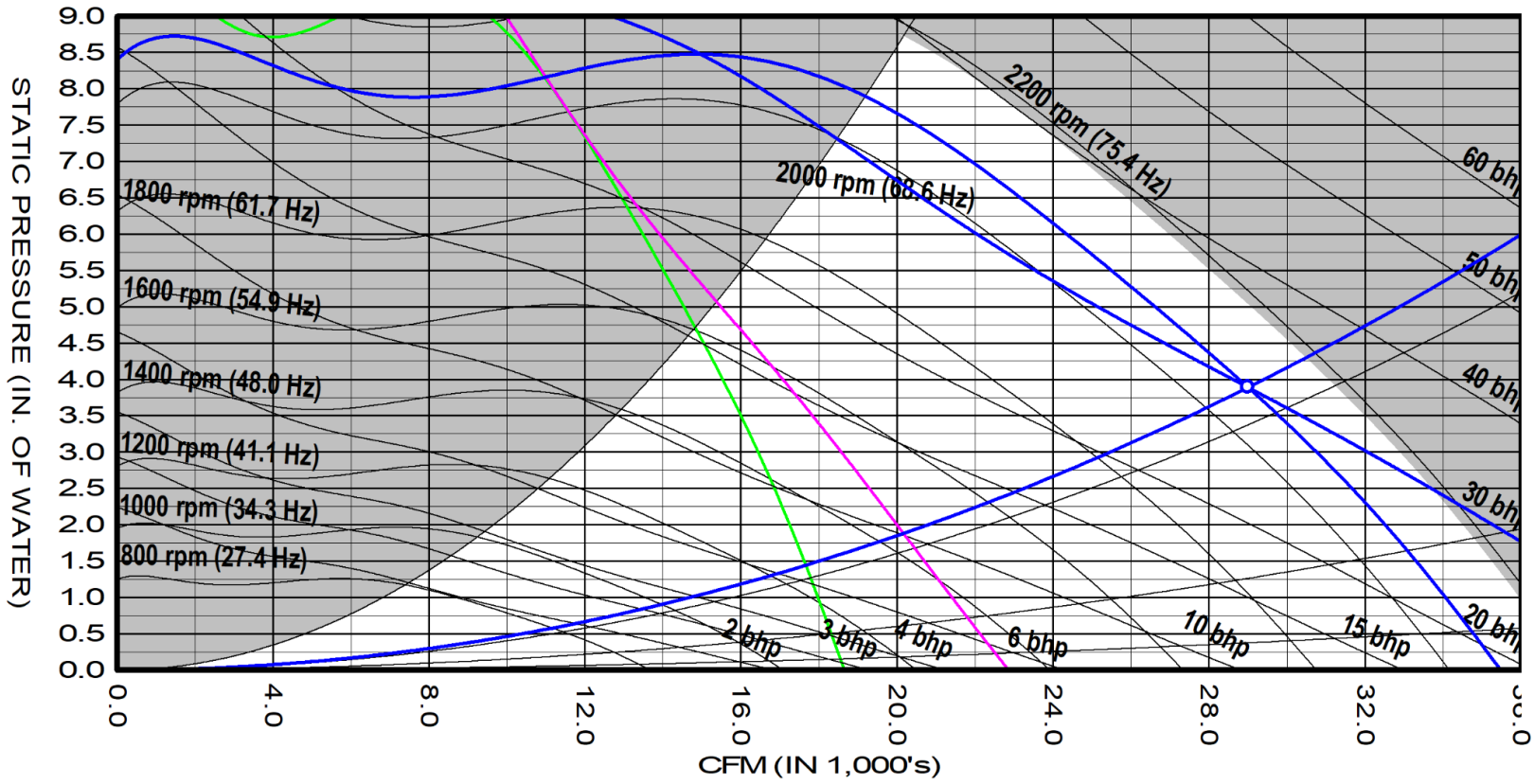

Green line = fan curve for 1 fan(s) at max speed

Red line = BHP curve for 1 fan(s) at max power of selected motor

AF 24 DD PLENUM 9BL (100% Width) 1x2 Supply Fan at Standard Conditions					
Air volume	29000	cfm	Fan speed	2077	rpm
Total static	3.89	insWg	Max speed	2183	rpm
Fan Shaft Power	30.0	bhp	Efficiency	59.1	%
Approx VFD Setting	71.2	Hz	Motor Speed	1750	rpm
Fan Energy Index(FEI)	1.01		Redundancy	60.8	%
Unit tagging	AHU-1 50% ODA		Date	April-01-2026	
Job name	22600705 - DCDSB Archbishop Dennis OcTime r 21:45				



Supply fan performance is certified in accordance with the Central Station Air-Handling Unit Certification Program, which is based on AHRI Standard 430.

HANDING ON THIS SIDE

ACCESSORIES ON OPPOSITE SIDE OF UNIT. SEE NOTE ON HANDING

HANDING ON THIS SIDE

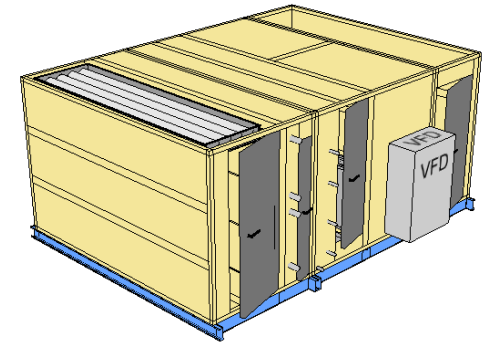
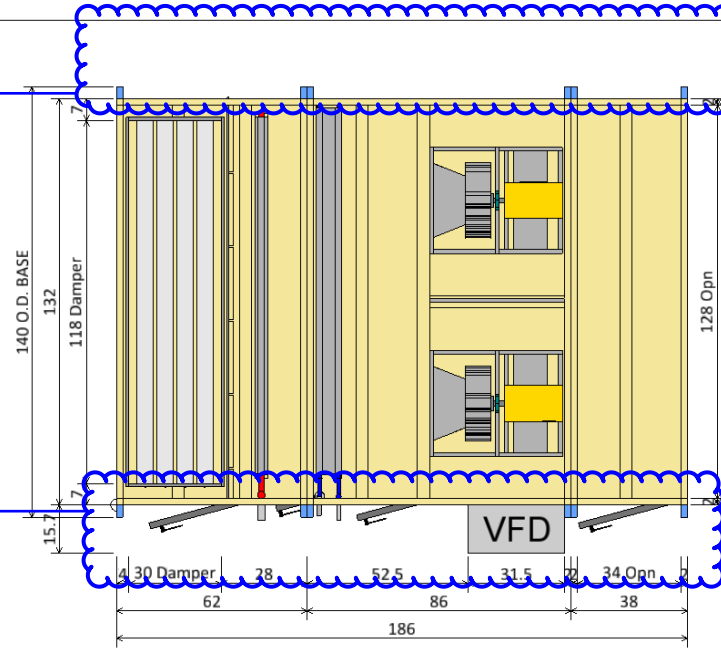

PLAN VIEW

ISOMETRIC VIEW

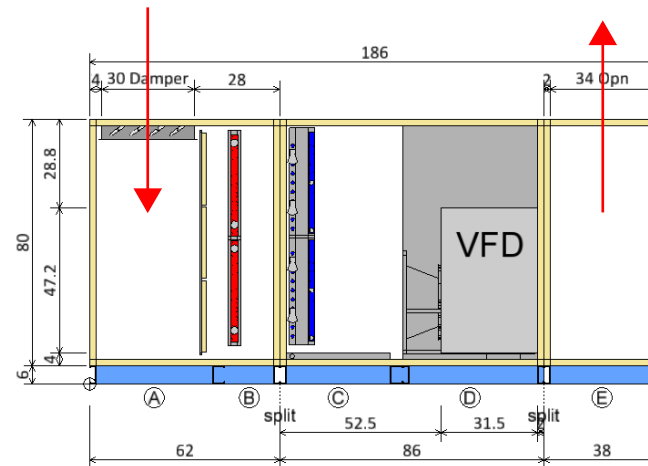

FRONT END VIEW

ELEVATION VIEW

REAR END VIEW

Plan/Elevation	Unit Tag: AHU-1 50% ODA	Sales Office: HTS Engineering Ltd.		 13600 Industrial Park Blvd, Minneapolis, MN 55441 www.DaikinApplied.com Software Version: 13.94		
Product: Vision Air Handler	Project Name: 22600705 - DCDSB Archbishop Dennis O'Connor					
Model: CAH059GDHM	Apr. 1, 2026	Ver/Rev:	Sheet: 1 of 1			Scale: NTS

All opening dimensions have a 1" mounting flange along the inner edge. The actual airflow area of the opening is 2" smaller in each dimension.

REW JM:
REFER TO NOTES
ON PREVIOUS
PAGE

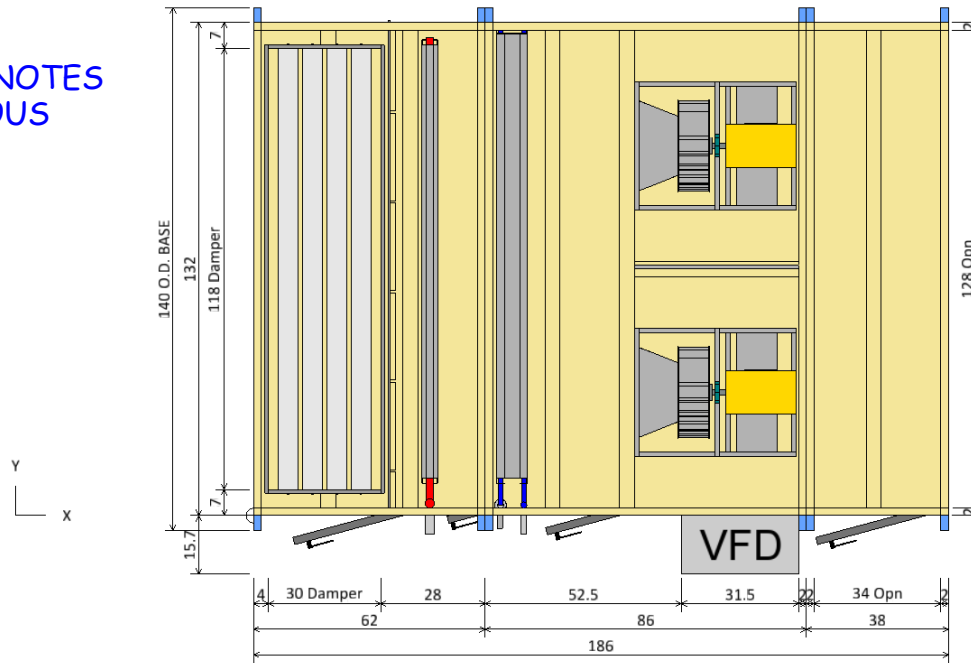

PLAN VIEW

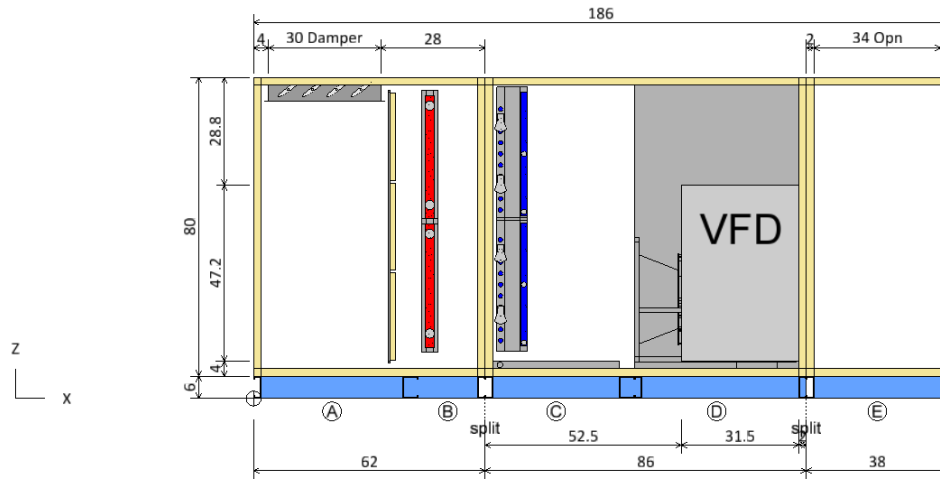

ELEVATION VIEW

Component Key

Mixing Box	
(A) Filter Type:	Pre Pleat M13
Right Door (WxH):	30 ins x 76 ins
Hot Water Coil	
(B) Coil Model:	5WS1002B
Total Capacity:	1749792.0 Btu/hr
Right Door (WxH):	8 ins x 68 ins
DX Coil	
(C) Coil Model:	5EJ1204C
Total Capacity:	970640.0 Btu/hr
Right Door (WxH):	20 ins x 68 ins
Supply Fan	
(D) Fan Type:	Centrifugal - Plenum
Fan Size (Class):	24 (2)
Air Flowrate:	14500.0 cfm
T.S.P.:	3.9 insWg
Motor Power:	20.0 HP
Control box door swing:	31.50 ins
Plenum Section	
(E) Opening Location:	Top
Opening Size:	34 ins x 128 ins
Right Door (WxH):	30 ins x 68 ins

Plan/Elevation - No Ends

Product: Vision Air Handler

Model: CAH059GDHM

Unit Tag: AHU-1 50% ODA

Project Name: 22600705 - DCDSB Archbishop Dennis Center

Apr. 1, 2026

Ver/Rev:

Sheet: 1 of 1

Sales Office: HTS Engineering Ltd.

Scale: NTS

Tolerance: +/-0.25"

Dwg Units: in



13600 Industrial Park Blvd, Minneapolis, MN 55441
www.DaikinApplied.com Software Version: 13.94

All opening dimensions have a 1" mounting flange along the inner edge. The actual airflow area of the opening is 2" smaller in each dimension.

REW JM:
REFER TO NOTES
ON PREVIOUS
PAGE

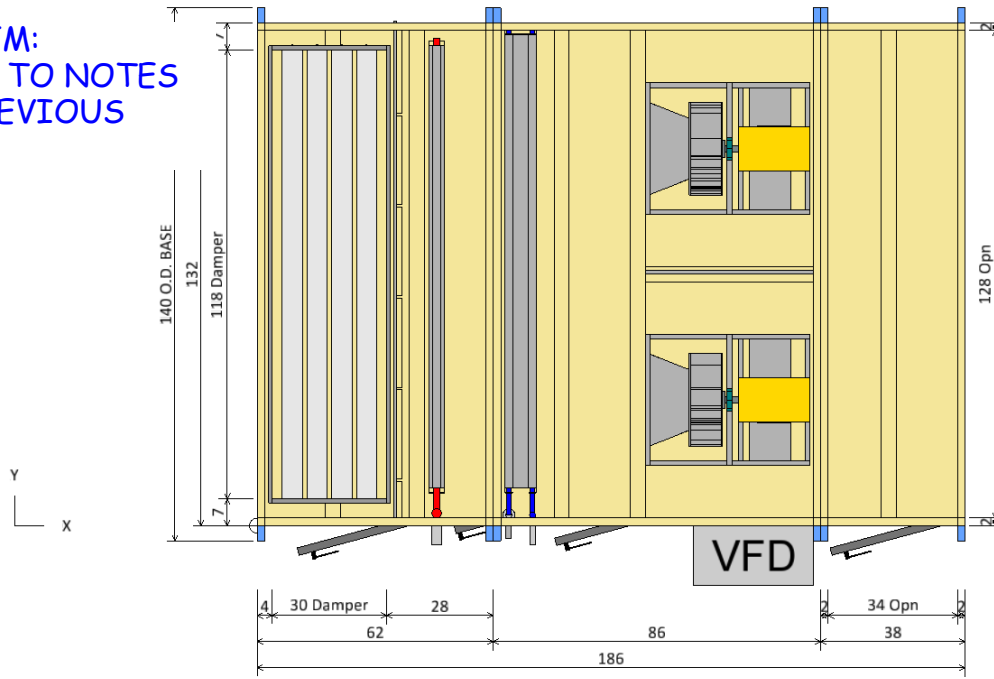

PLAN VIEW

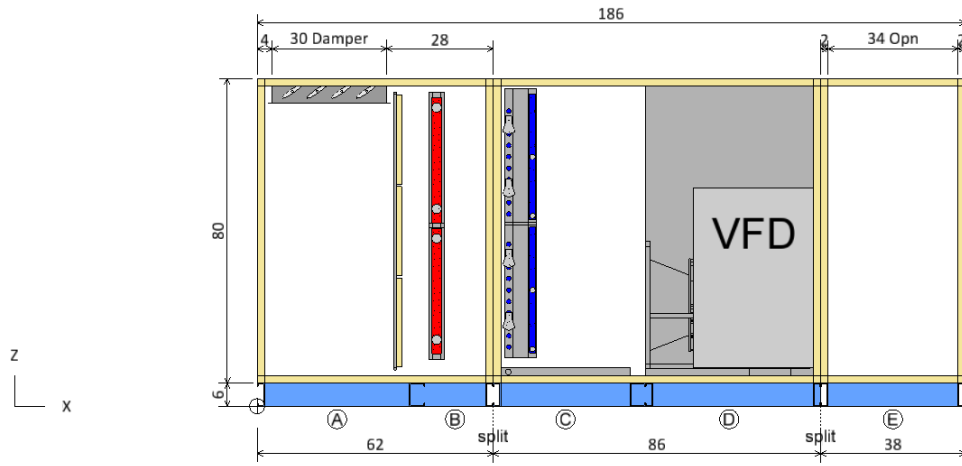

ELEVATION VIEW

Component Key

Type	X	Y	Z	Wid	Hgt
(A) Mixing Box					
Return air damper	2.00	2.00	86.00	30.00	118.00
(E) Plenum Section					
Opening	150.00	2.00	86.00	128.00	34.00

Note: Dimensions are measured from the origin point.
Note: Openings with or without dampers are recessed into the unit by approximately 1.75 in.

Opening/Damper Connections

Product: Vision Air Handler

Model: CAH059GDHM

Unit Tag: AHU-1 50% ODA

Project Name: 22600705 - DCDSB Archbishop Dennis Center

Apr. 1, 2026

Ver/Rev:

Sheet: 1 of 1

Sales Office: HTS Engineering Ltd.

Scale: NTS

Tolerance: +/-0.25"

Dwg Units: in



13600 Industrial Park Blvd, Minneapolis, MN 55441
www.DaikinApplied.com Software Version: 13.94

All opening dimensions have a 1" mounting flange along the inner edge. The actual airflow area of the opening is 2" smaller in each dimension.

REW JM:
REFER TO NOTES
ON PREVIOUS
PAGE

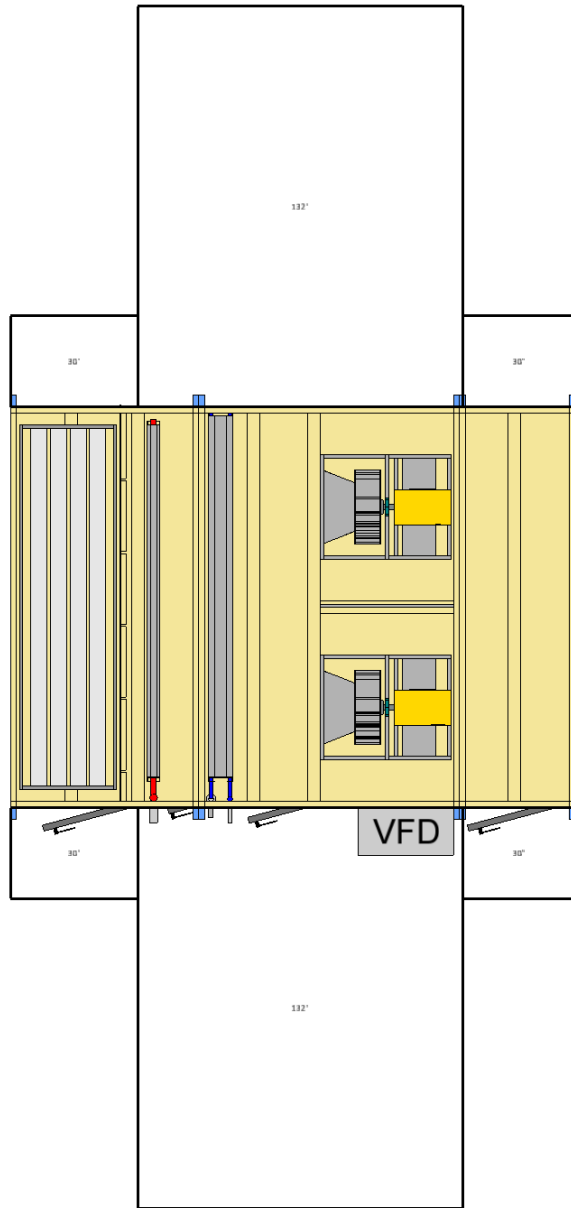

Notes

Check local electrical component service clearance codes for specific distances.

Access is only required on one side of the unit.

PLAN VIEW

Service Clearance View		Unit Tag: AHU-1 50% ODA		Sales Office: HTS Engineering Ltd.			 13600 Industrial Park Blvd, Minneapolis, MN 55441 www.DaikinApplied.com Software Version: 13.94
Product: Vision Air Handler		Project Name: 22600705 - DCDSB Archbishop Dennis O'Connor					
Model: CAH059GDHM	Apr. 1, 2026	Ver/Rev:	Sheet: 1 of 1	Scale: NTS	Tolerance: +/-0.25"	Dwg Units: in	
All opening dimensions have a 1" mounting flange along the inner edge. The actual airflow area of the opening is 2" smaller in each dimension.							

REW JM:
REFER TO NOTES
ON PREVIOUS
PAGE

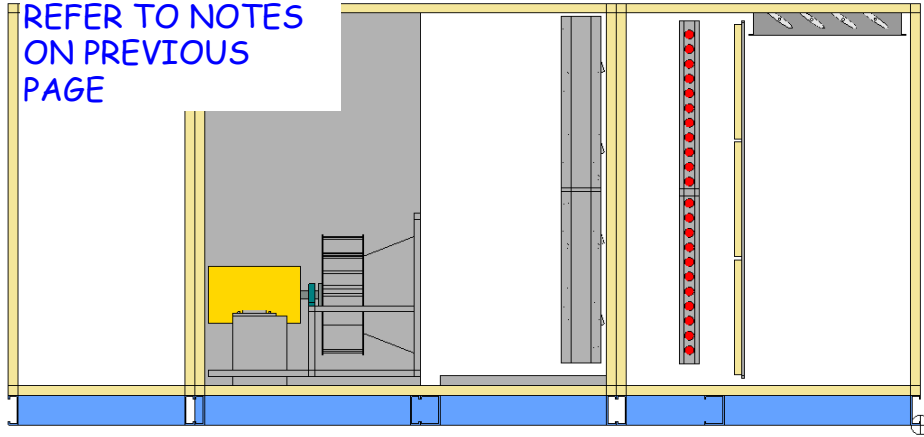

LEFT ELEVATION VIEW

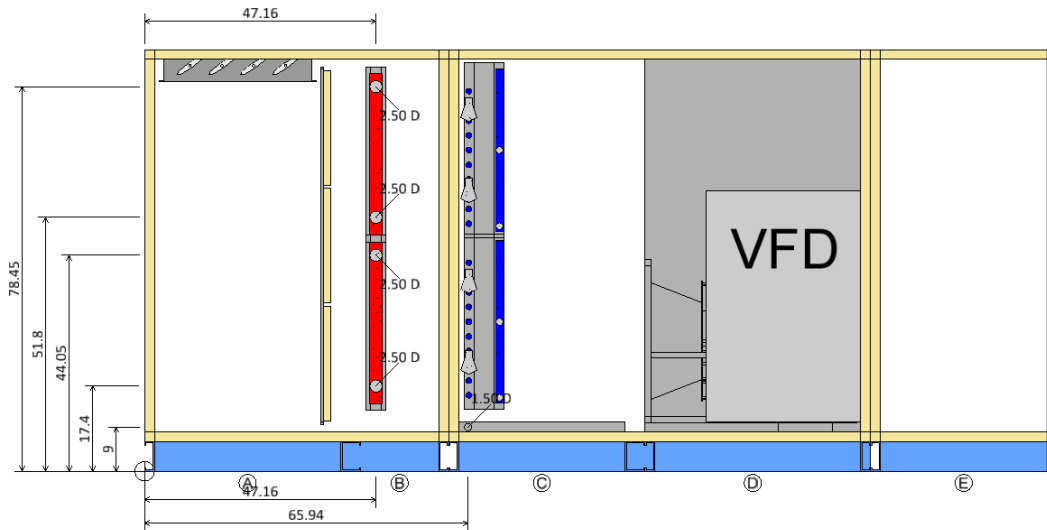

RIGHT ELEVATION VIEW

Coil and Drain Connections

Type	X	Y	Z	Diam
Hot Water Coil				
Hot water inlet:	47.16	-7.00*	17.40	2.50
Hot water outlet:	47.16	-7.00*	44.05	2.50
Hot water inlet:	47.16	-7.00*	51.80	2.50
Hot water outlet:	47.16	-7.00*	78.45	2.50
DX Coil				
Condensate drain conn:	65.94	-3.40	9.00	1.50
DX suction:	TBD	TBD	TBD	2- 1.63
DX liquid conn:	TBD	TBD	TBD	2- 1.38
DX suction:	TBD	TBD	TBD	2- 1.63
DX liquid conn:	TBD	TBD	TBD	2- 1.38

Notes:
Dimensions are measured from the origin point.
* value varies +/- 1 in.

Coil and Drain Connections

Unit Tag: AHU-1 50% ODA

Sales Office: HTS Engineering Ltd.

Product: Vision Air Handler

Project Name: 22600705 - DCDSB Archbishop Dennis Center

Model: CAH059GDHM

Apr. 1, 2026

Ver/Rev:

Sheet: 1 of 1

Scale: NTS

Tolerance: +/-0.25"

Dwg Units: in



13600 Industrial Park Blvd, Minneapolis, MN 55441
www.DaikinApplied.com Software Version: 13.94

All opening dimensions have a 1" mounting flange along the inner edge. The actual airflow area of the opening is 2" smaller in each dimension.

REW JM:
REFER TO NOTES
ON PREVIOUS
PAGE

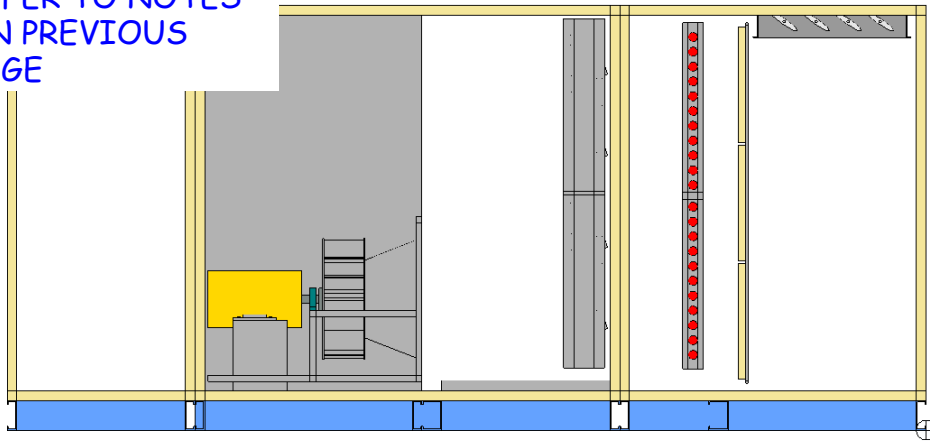

LEFT ELEVATION VIEW

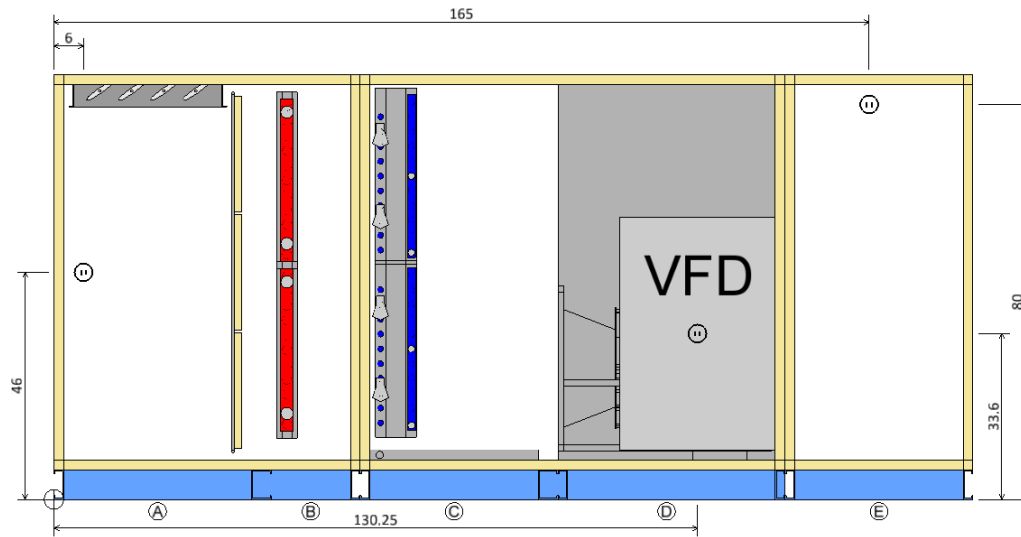

RIGHT ELEVATION VIEW

Component Key

Type	X	Y	Z	Volts	Phase
(A) Mixing Box LED Marine Light	6.00	0.00	46.00	110	1
(D) Supply Fan Fan	130.25	0.00	33.60	575	3
(E) Plenum Section LED Marine Light	165.00	0.00	80.00	110	1

Note: Dimensions are measured from the origin point.

Electrical Connections	Unit Tag: AHU-1 50% ODA	Sales Office: HTS Engineering Ltd.				 13600 Industrial Park Blvd, Minneapolis, MN 55441 www.DaikinApplied.com Software Version: 13.94
Product: Vision Air Handler	Project Name: 22600705 - DCDSB Archbishop Dennis Center	Dennis Engineer				
Model: CAH059GDHM	Apr. 1, 2026	Ver/Rev:	Sheet: 1 of 1	Scale: NTS	Tolerance: +/-0.25"	

All opening dimensions have a 1" mounting flange along the inner edge. The actual airflow area of the opening is 2" smaller in each dimension.

REW JM:
REFER TO NOTES
ON PREVIOUS
PAGE

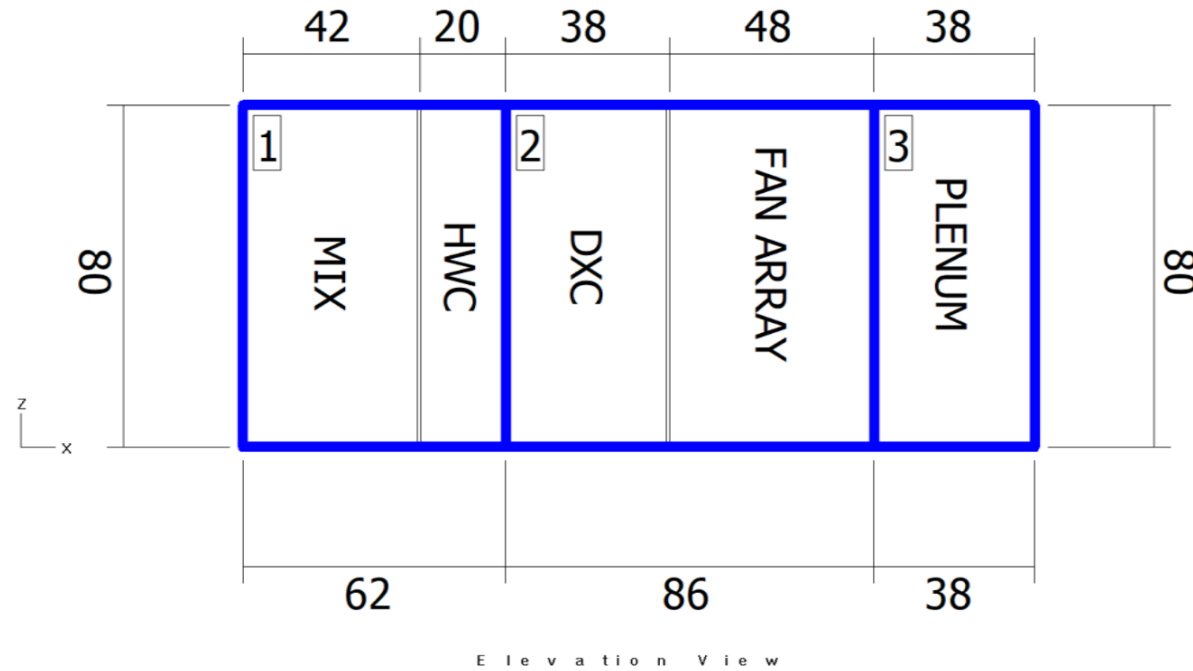



Shipping Sections				
Section	Weight (lb)	X	Y	Z
Section 1	2054.74	62	132	80
Section 2	4275.96	86	132	80
Section 3	797.56	38	132	80
Total Unit	7128.26	186	132	80

Note: Base rails, curb ready base, coil connectors, drain connectors, and control boxes not included in height X, Y, Z dimensions. Shipping section may be 2" longer in air flow direction due to internal splice joint.

Shipping Sections		Unit Tag: AHU-1 50% ODA		Sales Office: HTS Engineering Ltd.			 13600 Industrial Park Blvd, Minneapolis, MN 55441 www.DaikinApplied.com Software Version: 13.94
Product: Vision Air Handler		Project Name: 22600705 - DCDSB Archbishop Dennis Center					
Model: CAH059GDHM	Apr. 1, 2026	Ver/Rev:	Sheet: 1 of 1	Scale: NTS	Tolerance: +/-0.25"	Dwg Units: in	
All opening dimensions have a 1" mounting flange along the inner edge. The actual airflow area of the opening is 2" smaller in each dimension.							

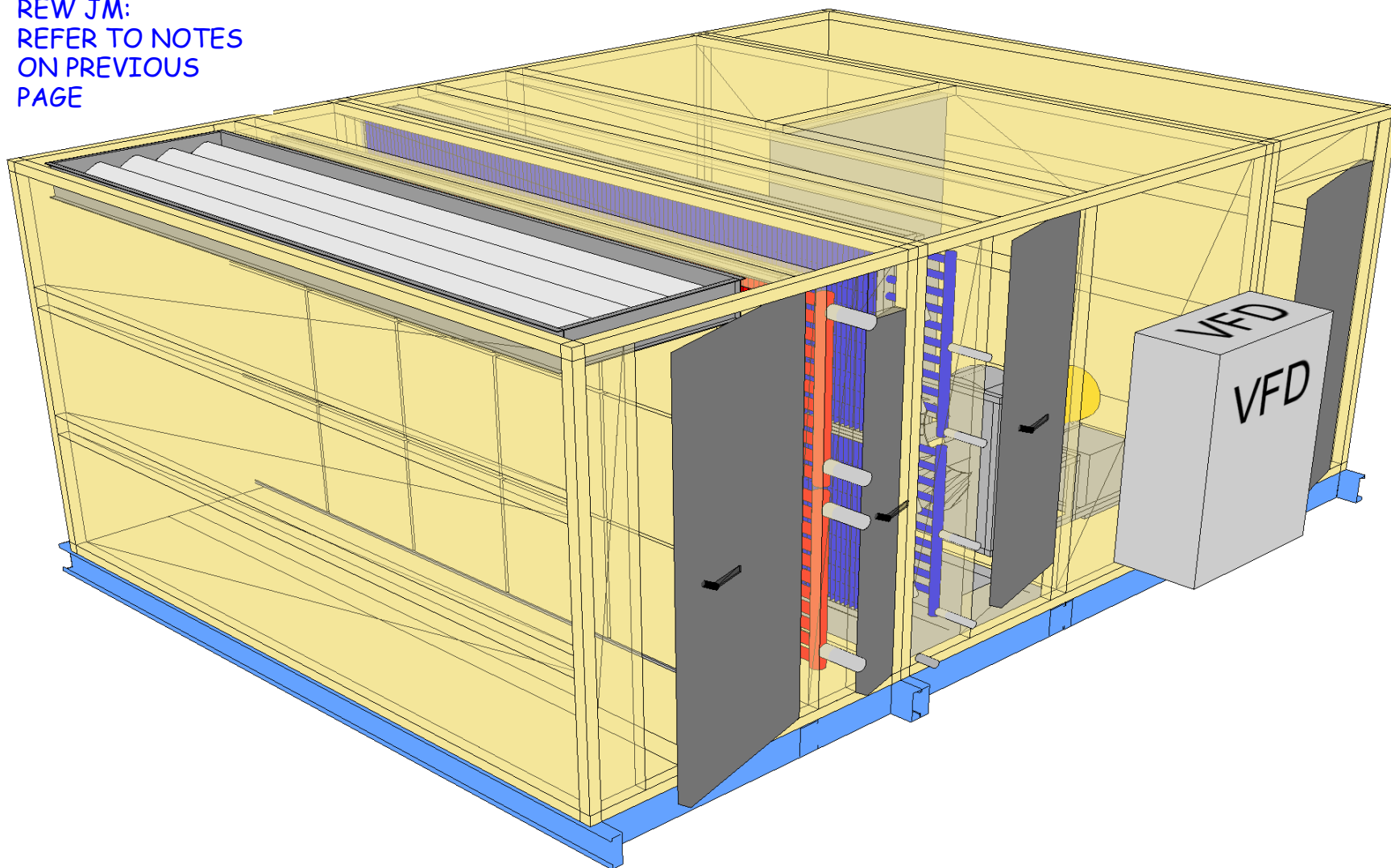
REW JM:
REFER TO NOTES
ON PREVIOUS
PAGE



Product Drawing	Unit Tag: AHU-1 50% ODA	Sales Office: HTS Engineering Ltd.					 13600 Industrial Park Blvd, Minneapolis, MN 55441 www.DaikinApplied.com Software Version: 13.94
Product: Vision Air Handler	Project Name: 22600705 - DCDSB Archbishop Dennis Center	Dennis Center					
Model: CAH059GDHM	Apr. 1, 2026	Ver/Rev:	Sheet: 1 of 1	Scale: NTS	Tolerance: +/-0.25"	Dwg Units: in	
All opening dimensions have a 1" mounting flange along the inner edge. The actual airflow area of the opening is 2" smaller in each dimension.							

Job Information		Technical Data Sheet	
Job Name	22600705 - DCDSB Archbishop Dennis Oconnor		
Date	01 April 2026		
Submitted By	Ellard Willson Engineering		
Software Version	13.94		
Unit Tag	AHU-2 50% ODA		

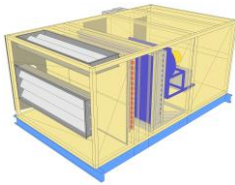

Unit Overview

Model Number	Supply					
	Air Volume cfm	Static Pressure		External Dimensions		
		External inWc	Total inWc	Height in	Width in	Length in
CAH020GDGM	8500	2.00	3.15	54*	76*	128

*Not including base rails, coil connectors, drain connectors and control boxes.

Unit

Model Number:	CAH020GDGM					
Approval:	ETL Listed / ETL Listed to Canadian Safety Standards (ETL Label / ETLc Label)					
Outer Panel:	Painted 24 gauge G60 Galvanized Steel (3000 hr. Salt Spray ASTM B-117)					
Liner:	24 gauge Galvanized Steel (unless noted per section)					
Insulation:	R-13 Injected Foam					
Unit Configuration:	Inline horizontal			Drive (Handling) Location:	Left	
Base:	6" formed channel			Wall Thickness:	2 in	
Altitude:	0 ft			Parts Warranty:	Standard One Year	

Mixing Box

Portion		Damper				Blade Action	Rated CFM	Air Pressure Drop	Quantity
Size (Width x Height)		Location	Type	Actuation					
Overall	Opening								
Outside Air	72 in x 24 in	62 in x 20 in	End	UltraSeal Low Leak	NA	Parallel	8500 cfm	0.12 insWg	1
Return Air	72 in x 22 in	62 in x 18 in	Top	UltraSeal Low Leak	NA	Parallel	8500 cfm		1

Filter Data

Type	Efficiency	Nominal Face Velocity	Actual Face Velocity	Actual Face Area	Air Volume	Filter Loading
Pleated	MERV 8	354 ft/min	373 ft/min	22.8 ft²	8500 cfm	Side
Air Pressure Drop				Number of Filters	Height	Width
Clean Air	Mean Air	Dirty Air	User Spec			Depth
0.16 inWc	0.58 inWc	1.00 inWc	N/A	6	24 in	24 in
						2 in

Door

Location	Width	Opening	Window Type
Drive side	26 in	Outward	Round

NO DAMPER

Hot Water Coil		Component: 2			Length: 12 in		Shipping Section: 1	
Coil Model	Total Capacity	Number of Coils	Number of Rows	Fins per Inch	Tube Diameter	Tube Spacing (Face x Row)		
5WH0902B	523742 Btu/hr	1	2	9	0.625 in	1.50 in x 1.299 in		
Coil Operating Weight				Coil Dry Weight				
167 lb				114 lb				
Air Volume	Air Temperature		Coil Air Pressure Drop	Finned Height	Finned Length	Face Area	Face Velocity	
	Entering	Leaving						
	Dry Bulb	Dry Bulb						
8500 cfm	34.0 °F	90.3 °F	0.17 inWc	42 in	60 in	17.50 ft²	486 ft/min	
Fluid								
Entering	Leaving	Flow Rate	Pressure Drop	Velocity	Fluid Volume	Fluid Weight		
170.0 °F	149.9 °F	56.00 gpm	11.60 ftHd	4.30 ft/s	6.0 gal	53.00 lb		
Connection [Data Per Coil]				Glycol Type	Min. Fin Surface Temp.	Min. Tube Wall Surface Temp.	Fouling Factor	
Type	Size	Location	Material					
Threaded	2.50 in	Drive side	Carbon steel	Propylene (40%)	149.9 °F	149.9 °F	0.000	
Material								
Fin		Tube		Header		Case		
Aluminum .0075 in		Copper .020 in		Copper		Galv. steel		
AHRI 410 Certification								
Coil is NOT certified by AHRI								

Direct Expansion Coil		Component: 3			Length: 38 in		Shipping Section: 1		
Coil Model	Total Capacity	Sensible Capacity	Number of Coils	Number of Rows	Fins per Inch	Tube Diameter	Tube Spacing (Face x Row)		
5EJ0806B	304711 Btu/hr	199527 Btu/hr	1	6	8	0.625 in	1.50 in x 1.299 in		
Coil Operating Weight									
370 lb									
Air Volume	Air Temperature				Coil Air Pressure Drop	Finned Height	Finned Length	Face Area	Face Velocity
	Entering		Leaving						
	Dry Bulb	Wet Bulb	Dry Bulb	Wet Bulb					
8500 cfm	76.0 °F	65.0 °F	54.5 °F	53.0 °F	0.65 insWg	42 in	63 in	18.38 ft²	463 ft/min
Fluid			Sub-Cooled Refrigerant Liquid Temp.	Suction Vapor Superheat Temp. at Coil Outlet	Design Saturated Condensing Temp.	Total Refrigerant Weight			
Suction Temp.	Refrigerant								
44.0 °F	R410a		110.0 °F	8.0 °F	110.0 °F	58.00 lb			
Connection [Data Per Coil]						Min. Fin Surface Temp.	Min. Tube Wall Surface Temp.		
Type	Liquid [Qty - Size]	Suction [Qty - Size]	Location	Material					
OD Sweat	2-0.88 in	2-1.63 in	Drive side	Copper tube		32.0 °F	32.0 °F		
Material						Drain Pan	Drain Side		
Fin	Tube	Header	Case						
Aluminum .0075 in	Copper .020 in	Copper	Galv. steel		Stainless steel	Drive side			
Total Refrigerant Weight is the total for all circuits of all coils in this coil section and is estimated. Refer to the AHU and Condensing Unit IOMs for recommendations on system start-up.									
Minimum allowable face velocity = 150 fpm									
AHRI 410 Certification									
Coil is NOT certified by AHRI									
Door									
Location			Width			Opening			
Drive side			22 in			Outward			

Supply Fan	Component: 4	Length: 48 in	Shipping Section: 1
-------------------	--------------	---------------	---------------------

Fan Performance									
Air Volume	Static Pressure			Fan Energy Index(FEI)	Total Input Power	Fan Shaft Power	Fan Wheel Speed		Outlet Velocity
	External	Total	Cabinet				Operating	Maximum	
8500 cfm	2.00 inWc	3.15 inWc	0.06 inWc	1.29	5.4 kW	6.15 BHP	1480 rpm	2183 rpm	N/A

Fan Data									
Fan Type	Blade Type / Class	Nominal Fan Size	Quantity of Fans	Wheel Diameter	Material Type	Number of Blades	Discharge	Motor Location	
Centrifugal - Plenum	Airfoil / 2	DDPL24	1	24.50 in	Aluminum	9	Top, single opening	Behind Fan	

Motor Data									
Power	Electrical Supply	Speed	Efficiency	Enclosure	Frame Size	Supplier	Number of Poles	Lock Rotor Current	Full Load Current
7.5 HP	575/60/3 V/Hz/Phase	1750 rpm	Premium	ODP	213 T frame	Generic	4	56.45 A	8.01 A

Fan Options	
Isolator Type:	Spring

VFD/Starter/Disconnect Data			
Selection Type:	VFD	Vendor:	Danfoss (FC101)
Auxiliary Control:	Disconnect	VFD Power:	7.5 HP
Voltage:	575 v	Disconnect Type:	Fused
Height x Width x Depth:	15.23 in x 7.60 in x 9.25 in	Mounting:	Door Side
Enclosure:	NEMA 1	VFD Quantity:	1

Door				
Location	Width	Opening	Window Type	LED Light
Drive side	16 in	Outward	Round	LED marine light kit and switch only

Unit Sound Power (dB)								
Type	63 Hz	125 Hz	250 Hz	500 Hz	1000 Hz	2000 Hz	4000 Hz	8000 Hz
Radiated:	71	69	70	60	58	50	46	51
Unit Discharge:	81	79	84	81	80	78	71	68
Unit Return:	71	69	76	65	63	63	54	51

REW JM COMMENTS:
 UNITS TO BE FULLY BROKEN DOWN TO PASS THROUGH A SINGLE DOOR.

Shipping Section Details

Section	Length in	Weight lb	Corner Weights (lb)				Center of Gravity (in)		
			P1	P2	P3	P4	XX	YY	ZZ
1	128	2535	604	668	663	599	64	40	28
Entire Unit	128	2535	604	668	663	599	64	40	28

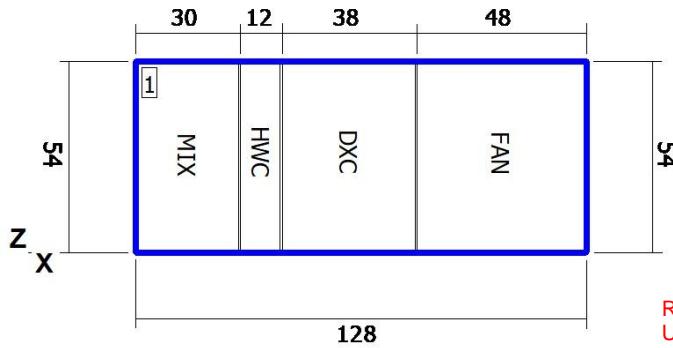

Elevation View

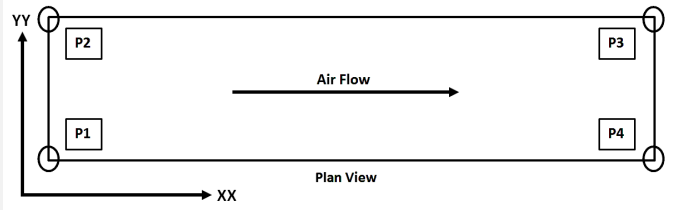

REW JM COMMENTS:
UNITS TO BE FULLY BROKEN DOWN TO PASS THROUGH A SINGLE DOOR.

NOTE: Special components aren't included in the corner weights and center of gravity data.

NOTE: Shipping weights listed do not include weight of water (listed in coil section(s) above).

Shipping Protection

None

Supply Static Pressure Drop

Component	Option	Static Pressure Drop
Mixing Box	Filter	0.16 insWg
Mixing Box	Mixing Box	0.12 insWg
Hot Water Coil	Hot Water Coil	0.17 insWg
DX Coil	DX Coil	0.65 insWg
Supply Fan	Cabinet	0.06 insWg
External Static	External Static	2.00 insWg
Total Supply Fan Static		3.15 insWg

Minimum Recommended Drain Pan Trap Dimensions

Shipping Section	Component	H
1	DX Coil	2.70

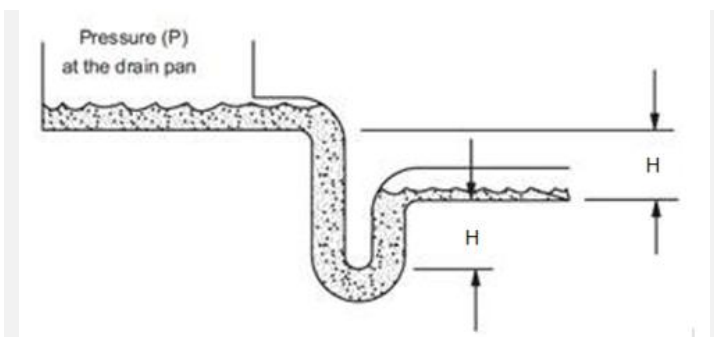

Dimensions provided as a courtesy and are recommended minimums only. Daikin is not responsible for supplying or designing drain pan traps and is not responsible for any damage caused by incorrect trap heights. The dimensions listed above should be reviewed and approved by a licensed plumbing professional.

This calculation is based on an assumption that 0.25 inches of the external static pressure is in the return duct and the remainder is in the supply duct. If actual conditions vary from this assumption then contact Applications for new trap height recommendations.

AHRI Certification



Certified by the AHRI Central Station Air-Handling Unit (AHU) Certification Program, which is based on AHRI Standard 430/431. AHRI certified units are subject to rigorous and continuous testing, have performance ratings independently measured and are third-party verified. Certified units may be found in the AHRI Directory at www.ahridirectory.org.

Notes

Standard

1. As a standalone component, unit meets or exceeds requirements of ASHRAE 90.1 - 2007. The approving authority is responsible for compliance of multi - component building systems.

Daikin AHU Fan Curve

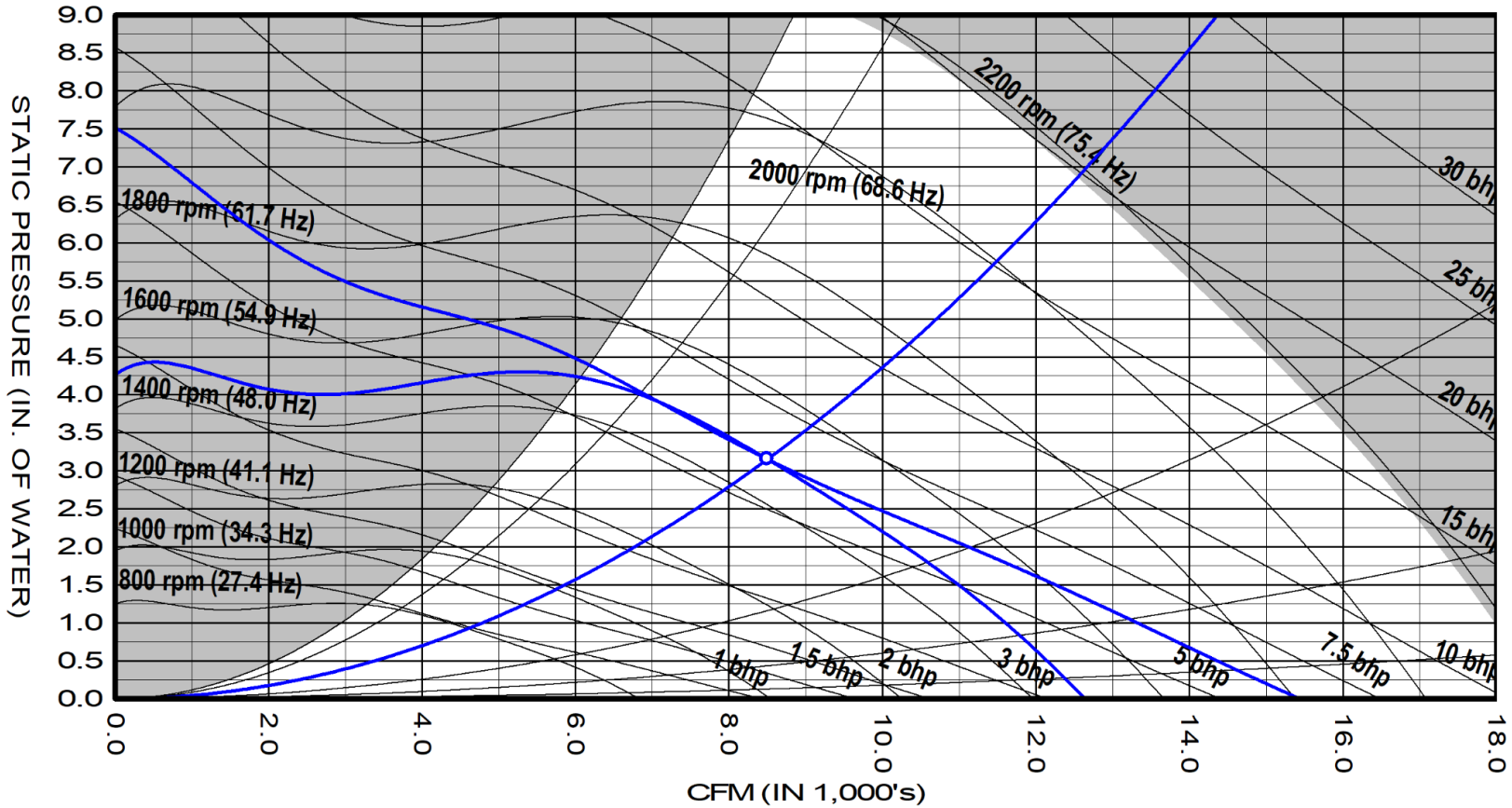

AF 24 DD PLENUM 9BL (100% Width) 1x1 Supply Fan at Standard Conditions					
Air volume	8500	cfm	Fan speed	1480	rpm
Total static	3.15	insWg	Max speed	2183	rpm
Fan Shaft Power	6.2	bhp	Efficiency	68.5	%
Approx VFD Setting	50.7	Hz	Motor Speed	1750	rpm
Fan Energy Index(FEI)	1.29				
Unit tagging	AHU-2 50% ODA		Date	April-01-2026	
Job name	22600705 - DCDSB Archbishop Dennis OcTime r 21:45				



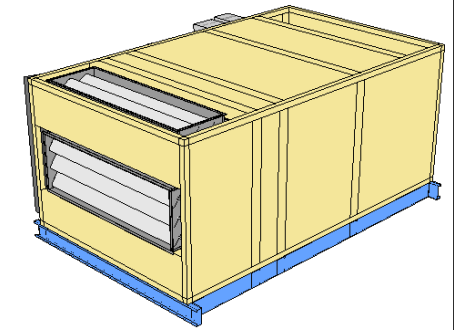
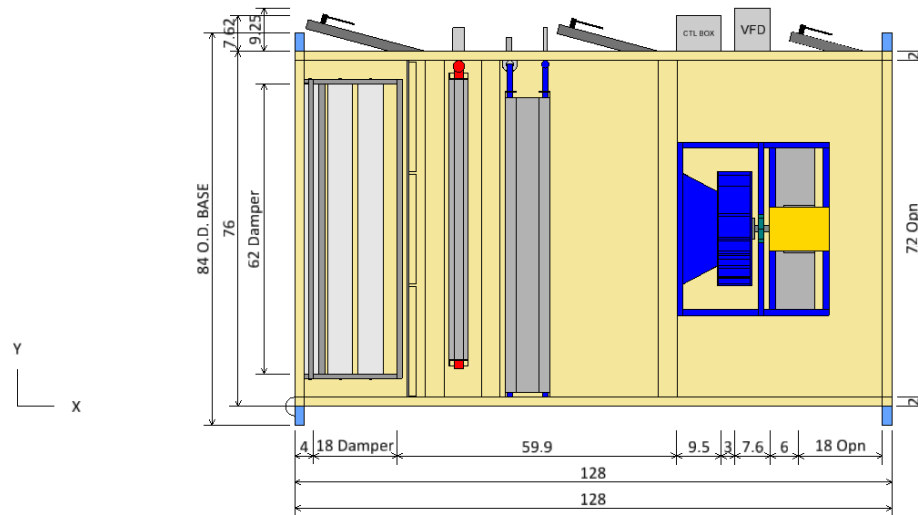

Supply fan performance is certified in accordance with the Central Station Air-Handling Unit Certification Program, which is based on AHRI Standard 430.

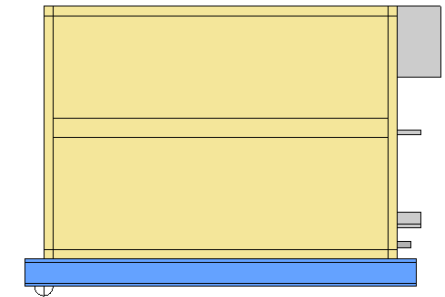
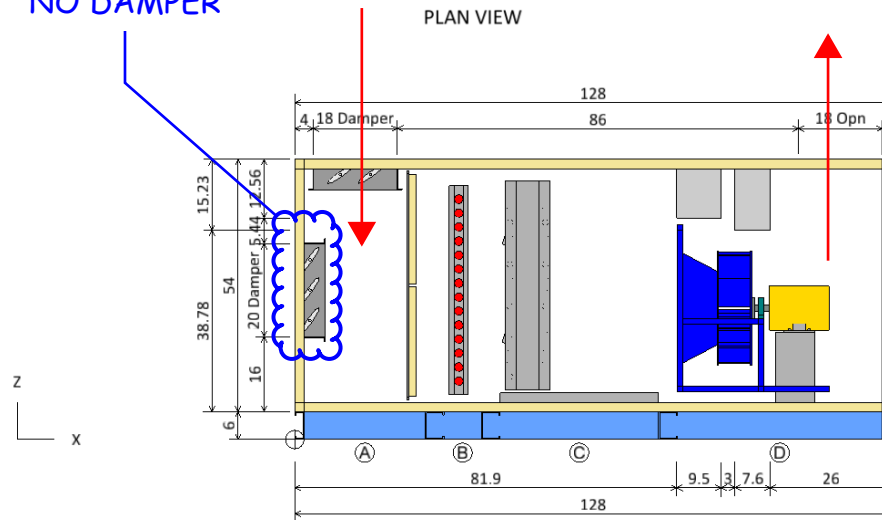
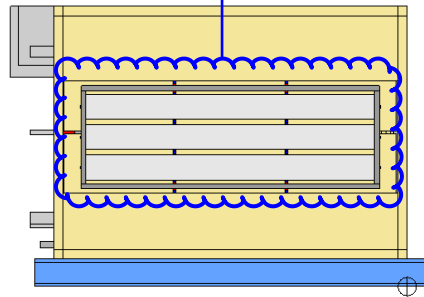

NO DAMPER

NO DAMPER



FRONT END VIEW		ELEVATION VIEW				REAR END VIEW	
Plan/Elevation		Unit Tag: AHU-2 50% ODA		Sales Office: HTS Engineering Ltd.		 13600 Industrial Park Blvd, Minneapolis, MN 55441 www.DaikinApplied.com Software Version: 13.94	
Product: Vision Air Handler		Project Name: 22600705 - DCDSB Archbishop Dennis O'Donnell					
Model: CAH020GDGM		Apr. 1, 2026	Ver/Rev:	Sheet: 1 of 1	Scale: NTS		
All opening dimensions have a 1" mounting flange along the inner edge. The actual airflow area of the opening is 2" smaller in each dimension.							

REW JM:
REFER TO NOTES
ON PREVIOUS
PAGE

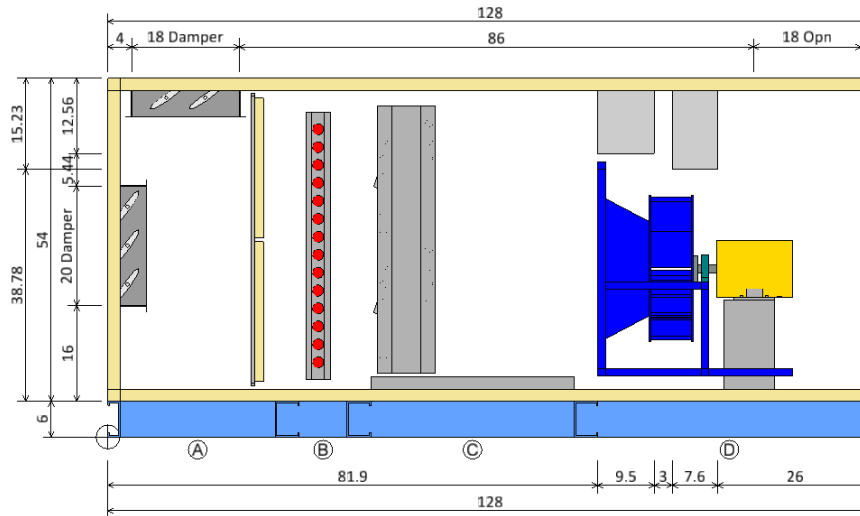
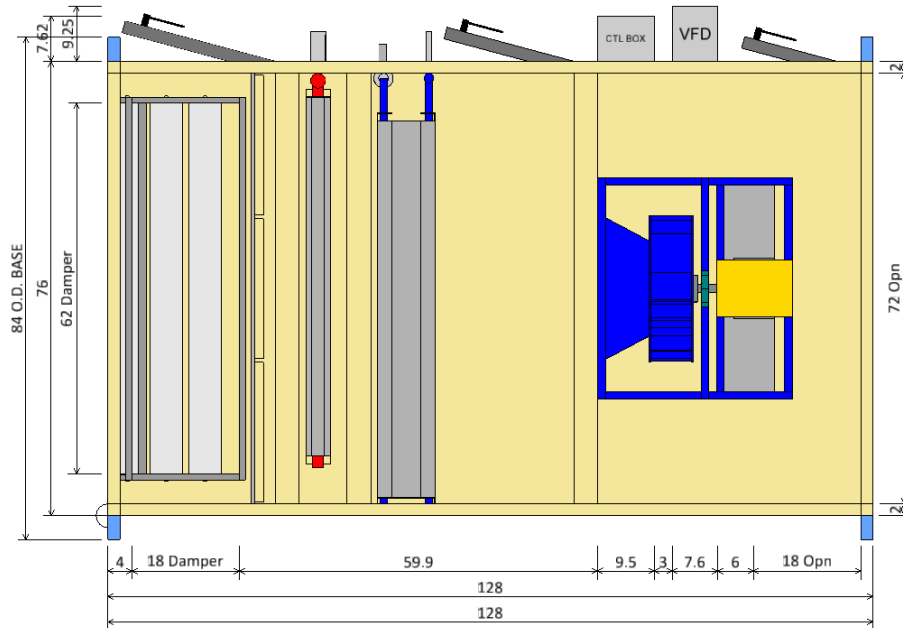

Component Key

Mixing Box	
(A) Filter Type:	PerfectPleat HC M8
Left Door (WxH): 26 ins x 50 ins	
Hot Water Coil	
(B) Coil Model:	5WH0902B
Total Capacity: 523742.0 Btu/hr	
DX Coil	
(C) Coil Model:	5EJ0806B
Total Capacity: 304711.0 Btu/hr	
Left Door (WxH): 22 ins x 44 ins	
Supply Fan	
Fan Type:	Centrifugal - Plenum
Fan Size (Class):	24 (2)
(D) Air Flowrate:	8500.0 cfm
T.S.P.:	3.1 insWg
Motor Power:	7.5 HP
VFD door swing:	7.60 ins
Left Door (WxH): 16 ins x 44 ins	

Plan/Elevation - No Ends

Product: Vision Air Handler

Model: CAH020GDGM

Unit Tag: AHU-2 50% ODA

Project Name: 22600705 - DCDSB Archbishop Dennis Center

Apr. 1, 2026

Ver/Rev:

Sheet: 1 of 1

Sales Office: HTS Engineering Ltd.

Scale: NTS

Tolerance: +/-0.25"

Dwg Units: in



13600 Industrial Park Blvd, Minneapolis, MN 55441
www.DaikinApplied.com Software Version: 13.94

All opening dimensions have a 1" mounting flange along the inner edge. The actual airflow area of the opening is 2" smaller in each dimension.

REW JM:
REFER TO NOTES
ON PREVIOUS
PAGE

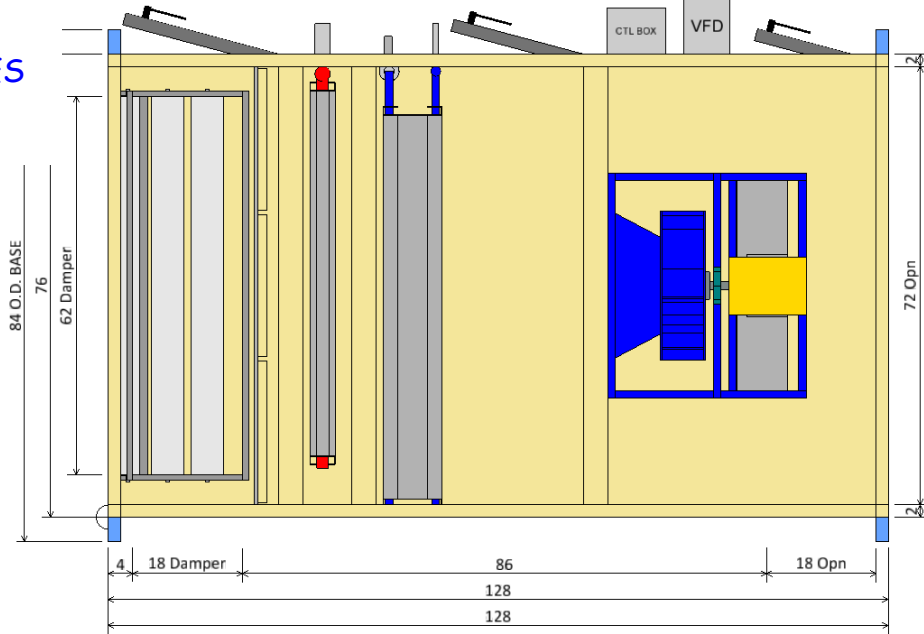

PLAN VIEW

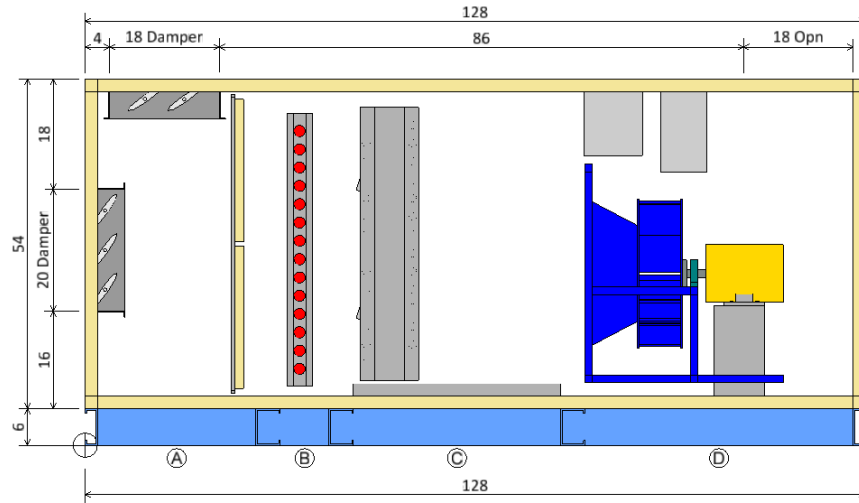

ELEVATION VIEW

Component Key

Type	X	Y	Z	Wid	Hgt
Mixing Box					
Ⓐ Outside air damper	0.00	2.00	20.00	72.00	24.00
Return air damper	2.00	2.00	60.00	18.00	62.00
Ⓓ Supply Fan					
Fan Discharge	108.00	2.00	60.00	72.00	18.00

Note: Dimensions are measured from the origin point.
Note: Openings with or without dampers are recessed into the unit by approximately 1.75 in.

Opening/Damper Connections

Product: Vision Air Handler

Model: CAH020GDGM

Unit Tag: AHU-2 50% ODA

Project Name: 22600705 - DCDSB Archbishop Dennis Center

Apr. 1, 2026

Ver/Rev:

Sheet: 1 of 1

Sales Office: HTS Engineering Ltd.

Scale: NTS

Tolerance: +/-0.25"

Dwg Units: in



13600 Industrial Park Blvd, Minneapolis, MN 55441
www.DaikinApplied.com Software Version: 13.94

All opening dimensions have a 1" mounting flange along the inner edge. The actual airflow area of the opening is 2" smaller in each dimension.

REW JM:
REFER TO NOTES
ON PREVIOUS
PAGE

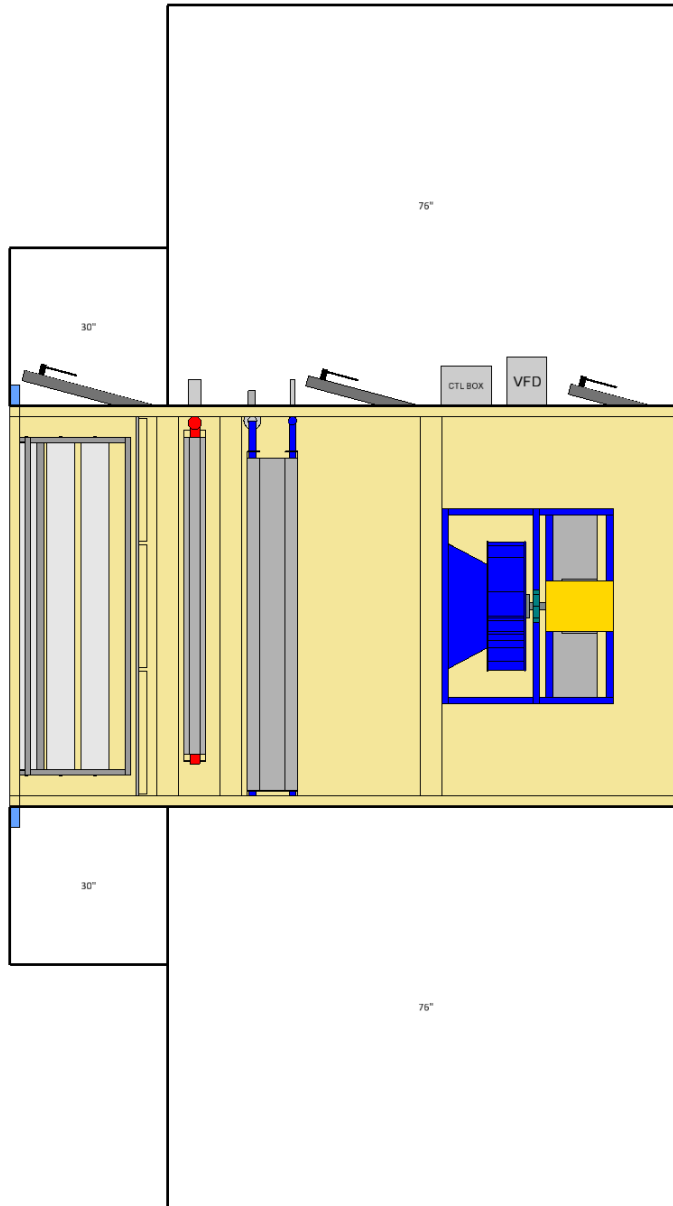

Notes

Check local electrical component service clearance codes for specific distances.

Access is only required on one side of the unit.

PLAN VIEW

Service Clearance View		Unit Tag: AHU-2 50% ODA		Sales Office: HTS Engineering Ltd.			 13600 Industrial Park Blvd, Minneapolis, MN 55441 www.DaikinApplied.com Software Version: 13.94
Product: Vision Air Handler		Project Name: 22600705 - DCDSB Archbishop Dennis Center					
Model: CAH020GDGM	Apr. 1, 2026	Ver/Rev:	Sheet: 1 of 1	Scale: NTS	Tolerance: +/-0.25"	Dwg Units: in	
All opening dimensions have a 1" mounting flange along the inner edge. The actual airflow area of the opening is 2" smaller in each dimension.							

REW JM:
REFER TO NOTES
ON PREVIOUS
PAGE

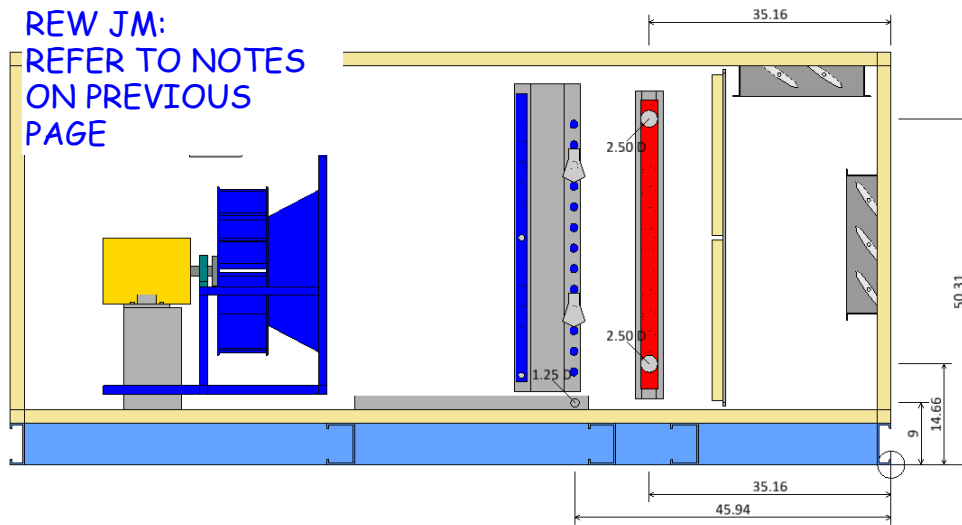

LEFT ELEVATION VIEW

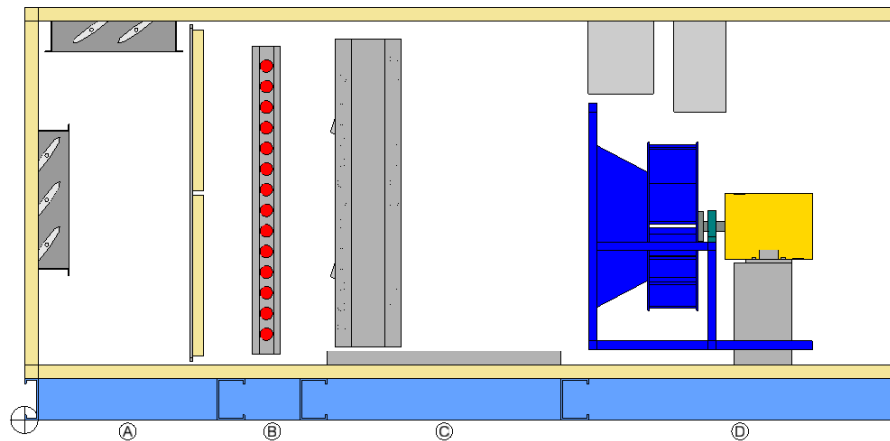

RIGHT ELEVATION VIEW

Coil and Drain Connections

Type	X	Y	Z	Diam	
Ⓑ Hot Water Coil Hot water inlet:	35.16	83.00*	14.66	2.50	
	Hot water outlet:	35.16	83.00*	50.31	2.50
Ⓒ DX Coil Condensate drain conn:	45.94	78.90	9.00	1.25	
	DX suction:	TBD	TBD	TBD	2- 1.63
	DX liquid conn:	TBD	TBD	TBD	2- 0.88

Notes:
Dimensions are measured from the origin point.
* value varies +/- 1 in.

Coil and Drain Connections

Product: Vision Air Handler

Model: CAH020GDGM

Unit Tag: AHU-2 50% ODA

Project Name: 22600705 - DCDSB Archbishop Dennis Center

Apr. 1, 2026

Ver/Rev:

Sheet: 1 of 1

Sales Office: HTS Engineering Ltd.

Scale: NTS

Tolerance: +/-0.25"

Dwg Units: in



13600 Industrial Park Blvd, Minneapolis, MN 55441
www.DaikinApplied.com Software Version: 13.94

All opening dimensions have a 1" mounting flange along the inner edge. The actual airflow area of the opening is 2" smaller in each dimension.

REW JM:
REFER TO NOTES
ON PREVIOUS
PAGE

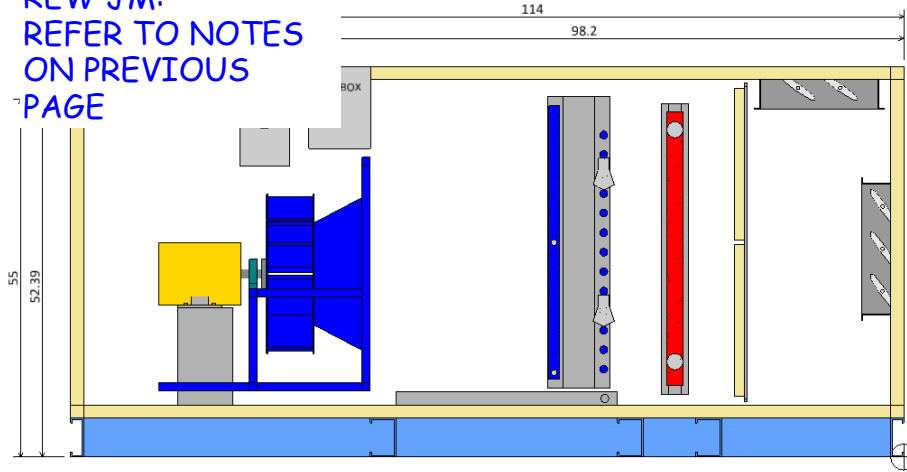

LEFT ELEVATION VIEW

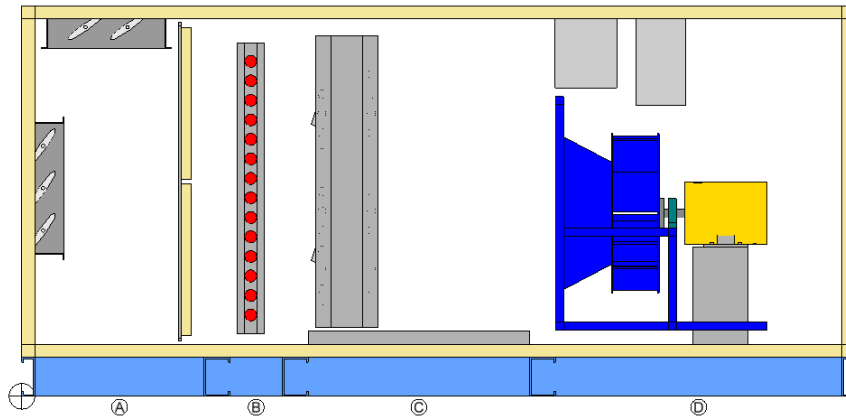

RIGHT ELEVATION VIEW

Component Key

Type	X	Y	Z	Volts	Phase
Supply Fan					
LED Marine Light	114.00	76.00	55.00	110	1
Fan	98.20	76.00	52.39	575	3

Note: Dimensions are measured from the origin point.

Electrical Connections

Product: Vision Air Handler

Model: CAH020GDGM

Unit Tag: AHU-2 50% ODA

Project Name: 22600705 - DCDSB Archbishop Dennis Center

Apr. 1, 2026

Ver/Rev:

Sheet: 1 of 1

Sales Office: HTS Engineering Ltd.

Scale: NTS

Tolerance: +/-0.25"

Dwg Units: in



13600 Industrial Park Blvd, Minneapolis, MN 55441
www.DaikinApplied.com Software Version: 13.94

All opening dimensions have a 1" mounting flange along the inner edge. The actual airflow area of the opening is 2" smaller in each dimension.

REW JM:
REFER TO NOTES
ON PREVIOUS
PAGE

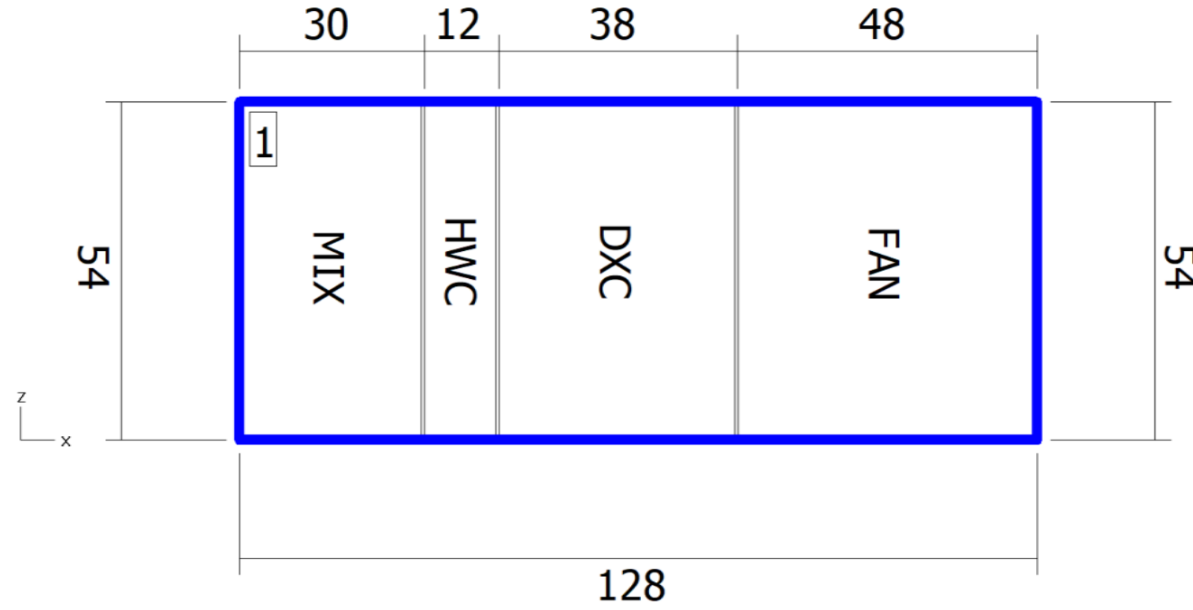

Elevation View

Shipping Sections

Section	Weight (lb)	X	Y	Z
Section 1	2534.85	128	76	54
Total Unit	2534.85	128	76	54

Note: Base rails, curb ready base, coil connectors, drain connectors, and control boxes not included in height X, Y, Z dimensions. Shipping section may be 2" longer in air flow direction due to internal splice joint.

Shipping Sections		Unit Tag: AHU-2 50% ODA		Sales Office: HTS Engineering Ltd.			 13600 Industrial Park Blvd, Minneapolis, MN 55441 www.DaikinApplied.com Software Version: 13.94
Product: Vision Air Handler		Project Name: 22600705 - DCDSB Archbishop Dennis O'Connell					
Model: CAH020GDGM	Apr. 1, 2026	Ver/Rev:	Sheet: 1 of 1	Scale: NTS	Tolerance: +/-0.25"	Dwg Units: in	

All opening dimensions have a 1" mounting flange along the inner edge. The actual airflow area of the opening is 2" smaller in each dimension.

REW JM:
REFER TO NOTES
ON PREVIOUS
PAGE

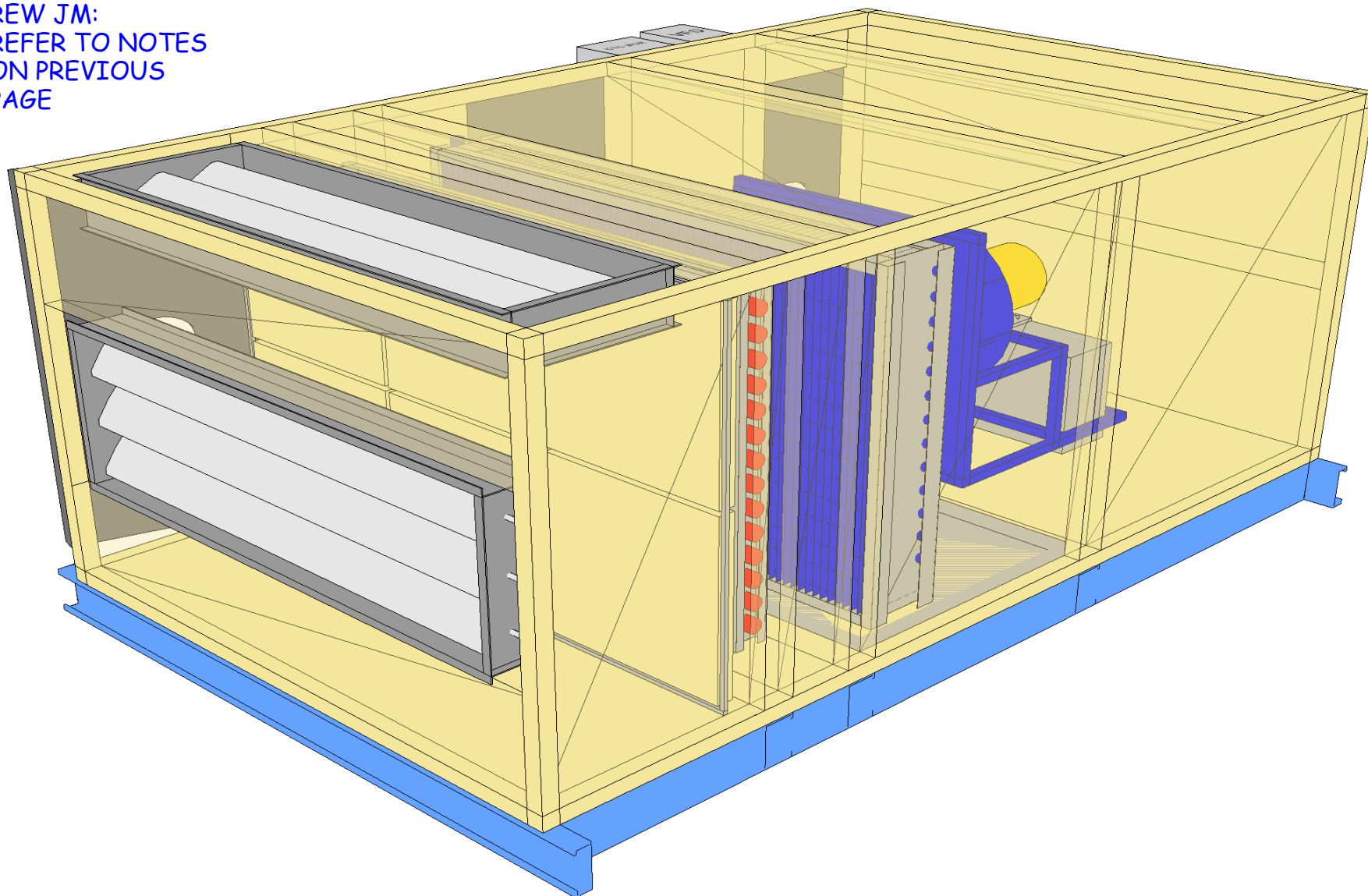

Product Drawing	Unit Tag: AHU-2 50% ODA	Sales Office: HTS Engineering Ltd.				 13600 Industrial Park Blvd, Minneapolis, MN 55441 www.DaikinApplied.com Software Version: 13.94
Product: Vision Air Handler	Project Name: 22600705 - DCDSB Archbishop Dennis Center					
Model: CAH020GDGM	Apr. 1, 2026	Ver/Rev:	Sheet: 1 of 1	Scale: NTS	Tolerance: +/-0.25" Dwg Units: in	
All opening dimensions have a 1" mounting flange along the inner edge. The actual airflow area of the opening is 2" smaller in each dimension.						



HTS Oshawa

2001 Thickson Rd, South
Unit #11
Whitby, ON L1N 6J3
T 905.579.6700
F 905.597.5290

ontario.htseng.com

SUBMITTAL DATA
APPROVAL REQUIRED

IOM LINK

https://htseng-my.sharepoint.com/:f:/g/personal/curtis_metrow_hts_com/IgD_JwPmhDmwQZINhdRqf-csAWEu08nbwsg2MnbpeWdmLds?e=AVpGVC

Submittal # 98346

APPROVAL REQUIRED

Project 22600705-OWN-1- DCDSB - Archbishop Denis O'Connor
Leader Curtis Metrow
Job Site 80 Mandrake St, Ajax, ON, Canada
Submission Date 2026-04-01
Sold To DURHAM CDSB *
Submitted By Curtis Metrow

Contacts

Role	Customer	Our Rep
Owner	Durham Catholic District School Board *	Curtis Metrow
Designer	Ellard Willson Engineering	Steve Cukrovani

Deliverables

Track #	335946	335949	335953
Tag	CU-1	CU-2	CU-3
Description	Air Cooled Condensing Unit	Air Cooled Condensing Unit	Air Cooled Condensing Unit
Quantity	1	1	1
Manufacturer	Daikin Applied	Daikin Applied	Daikin Applied
Specification			
Production Lead Time	15 - 17 Weeks	15 - 17 Weeks	15 - 17 Weeks
Revision #	1	1	1

Attention:

- 1) HTS will provide equipment in accordance with the attached shop drawings.
- 2) Upon approved submittal and customer release, HTS will release equipment to fabrication per the published lead times. Any storage fees associated with project schedule changes will be the responsibility of the purchaser.
- 3) HTS can provide freight and logistics to the purchaser as an added benefit of doing business with HTS. When freight is received by the purchaser, any noticeable damage must be recorded. Otherwise, HTS is not responsible for subsequent damage claims.

REW COMMENTS:
 - UNIT CONTOLS TO BE BACNET MSTP

Approval Stamps

RYBKA ELLARD WILLSON INC

- REVIEWED
- REVIEWED AS NOTED
- REVISE AND RESUBMIT



SUBMITTAL WAS REVIEWED FOR DESIGN CONFORMITY AND GENERAL CONFORMANCE TO CONTRACT DOCUMENTS ONLY. THE CONTRACTOR IS RESPONSIBLE FOR CONFIRMING AND CORRELATING DIMENSIONS AT JOB SITES FOR TOLERANCES, CLEARANCES, QUANTITIES, FABRICATION PROCESSES AND TECHNIQUES OF CONSTRUCTION, COORDINATION OF THEIR WORK WITH OTHER TRADES AND FULL COMPLIANCE WITH THE CONTRACT DOCUMENTS.

BY JMACQUARRIE

DATE 2026/4/6

RYBKA ELLARD WILLSON INC

- REVIEWED
- REVIEWED AS NOTED
- REVISE AND RESUBMIT



SUBMITTAL WAS REVIEWED FOR DESIGN CONFORMITY AND GENERAL CONFORMANCE TO CONTRACT DOCUMENTS ONLY. THE CONTRACTOR IS RESPONSIBLE FOR CONFIRMING AND CORRELATING DIMENSIONS AT JOB SITES FOR TOLERANCES, CLEARANCES, QUANTITIES, FABRICATION PROCESSES AND TECHNIQUES OF CONSTRUCTION, COORDINATION OF THEIR WORK WITH OTHER TRADES AND FULL COMPLIANCE WITH THE CONTRACT DOCUMENTS.

BY FCHANG

DATE 4/6/2026

REW COMMENTS:

- UNIT CONTOLS TO BE BACNET MSTP



HTS Oshawa

2001 Thickson Rd, South
Unit #11
Whitby, ON L1N 6J3
T 905.579.6700
F 905.597.5290

ontario.htseng.com

SUBMITTAL DATA
APPROVAL REQUIRED

AIR COOLED CONDENSING UNIT

CU-1,2,3

Technical Information And Drawings

Notes:

- 1) Electrical:
 - a. A single 575/3/60 electrical feed is required per unit
 - i. CU-1 MCA = 153.0 / MOCP = 175 – SCCR 10KAIC
 - ii. CU-2 MCA = 39.3 / MOCP = 50 – SCCR 10KAIC
 - iii. CU-3 MCA = 75.8 / MOCP = 90 – SCCR 10KAIC
 - b. Main non-fused disconnect is provided
- 2) Unit Options:
 - a. Staged cooling control
 - b. 2 circuits for integration with interlaced coils in air handling units.
- 3) Controls
 - a. Terminal strip for controls by others
- 4) Assembly Info:
 - i. Ships in single piece
- 5) Warranty
 - a. 2 year factory parts warranty included

Job Information		Technical Data Sheet
Job Name	22600705 - DCDSB Archbishop Dennis Oconnor	
Date	4/1/2026	
Submitted By	Terry Loyala	
Software Version	11.60	
Unit Tag	CU-1 (AHU-1)	



Unit Overview						
Model Number	Voltage V/Hz/Phase	Total Refrigeration Effect Btu/hr	Total Unit Power kW	EER AHRI Conditions	IEER AHRI Conditions	ASHRAE 90.1
RCS100D	575/60/3	1021755	100.0	10.4	14.8	2007 Compliant

Physical			
Dimensions and Weight			
Length	Height	Width	Operating Weight
103.0 in	97.0 in	99.0 in	3761 lb
Connections			
Connection	Connection Sizes		
Suction Line Circuit	(2) 2.62 in.		
Liquid Line Circuit	(2) 1.12 in.		
Hot Gas Bypass Circuit	(2) 0.88 in.		

Electrical					
Voltage	MROPD	Field Power Connection	MCA	SCCR	Field Outlet Connection
575/60/3 V/Hz/Phase	175 A	Thru-the-door disconnect switch	153.0 A	10 kAIC	115V, 20 amp service
Note:	Use only copper supply wires with ampacity based on 75° C conductor rating. Connections to terminals must be made with copper lugs and copper wire.				

Unit		
Model Number:	RCS100D	
Type:	Applied	
Approval:	ETL - Canada	
Refrigerant Type:	No. of Refrigerant Circuits	Refrigerant Weight
R410A	2	35.2 lb

Condensing Section

Temperature		Altitude	Refrigeration Effect	Power
Suction	Ambient			
45.0 °F	95.0 °F	0 ft	1021755 Btu/hr	100.0 kW

Compressor

Quantity	Type	Capacity Control	Compressor Isolation
6	Scroll	6 steps	Resilient

Full Load Current:

Compressor 1	19.9 A
Compressor 2	23.7 A
Compressor 3	19.9 A
Compressor 4	23.7 A
Compressor 5	19.9 A
Compressor 6	23.7 A

Condenser

Type	Coil		Fans	Fan Motors	
	Number of Rows	Fins per Inch	Condenser Fan Type	Quantity	Full Load Current
Aluminum tube micro channel	1	18	Standard	9	1.70 A

Sound

Casing Radiated Sound Power (db)

63 Hz	125 Hz	250 Hz	500 Hz	1 kHz	2 kHz	4 kHz	8 kHz
0	103	97	95	94	91	87	82

Options

Unit

Hot Gas Bypass:	HGBP Tee (See Accessory Tab)
Condenser Coil Options:	Condenser with built in hail protection

Electrical

Field Connection	Thru-the-door disconnect switch
Wiring Options	Sealtite conduit
GFI Receptacle	Field powered

Unit Control

Temperature Controls:	No temp control, 115 V transformer
Low Ambient Control:	Fantrol, Low ambient control to 45 degrees

Warranty

Parts:	Standard one year parts
Compressor:	Standard one year compressor

Notes

EER is not compliant with ASHRAE 90.1 - 2013 minimums. Select Case size 92 or 110 if 90.1 - 2013 Compliant unit is required.

2-YEAR

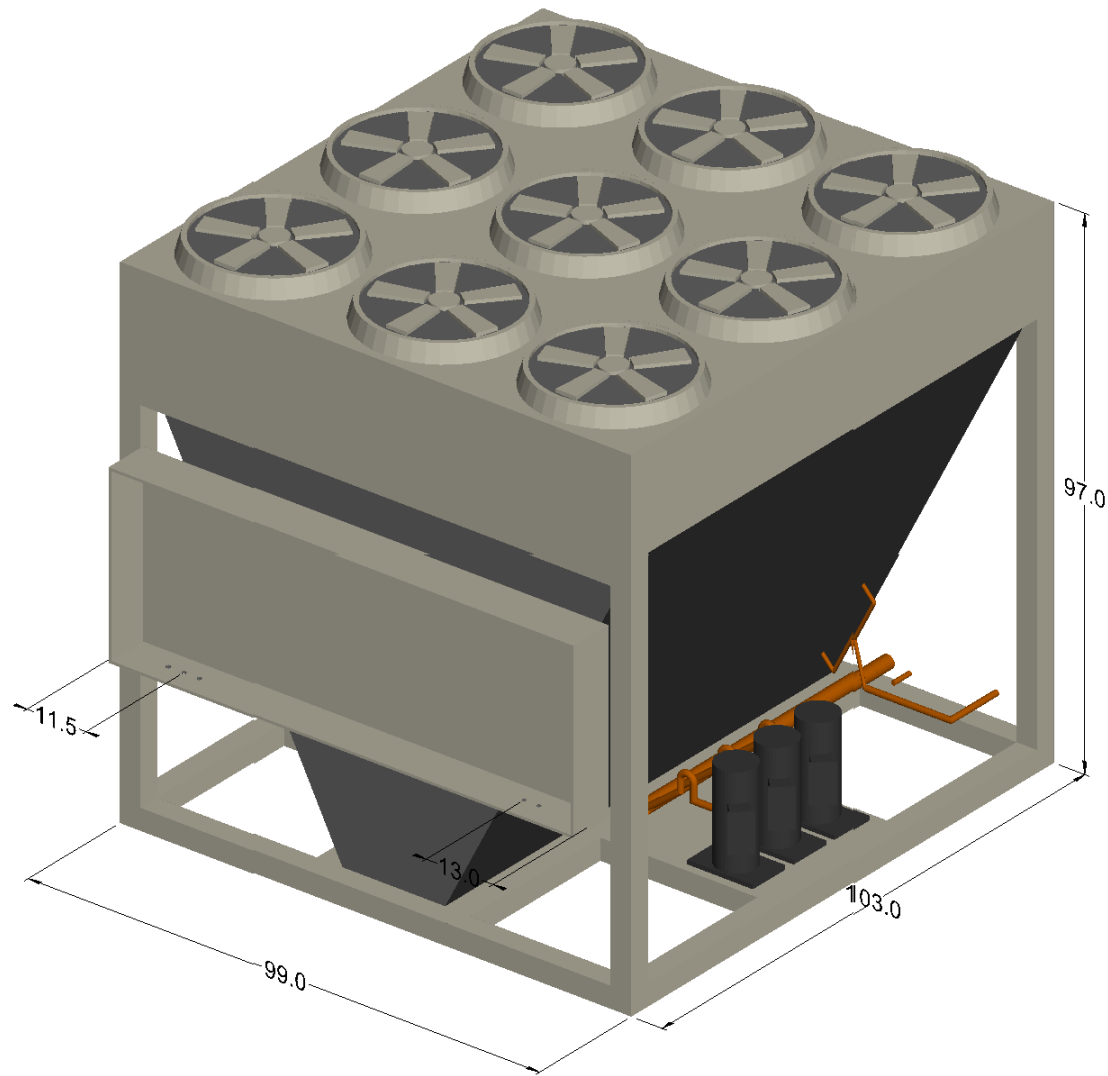

Product Drawing

Product:

Model: RCS100D

Unit Tag: CU-1 (AHU-1)

Project Name: 22600705 - DCDSB

Apr. 01, 2026

Ver/Rev:

Sheet: 1 of 1

Sales Office: HTS Engineering Ltd.

Sales Engineer:

Scale: NTS

Tolerance: +/- 0.25"

Dwg Units: in [mm]



13600 Industrial Park Blvd. Minneapolis, MN 55441
www.DaikinApplied.com Software Version: 11.60

No change to this drawing may be made unless approved in writing by Daikin Applied. Purchaser must determine that the equipment is fit and sufficient for the job specifications.

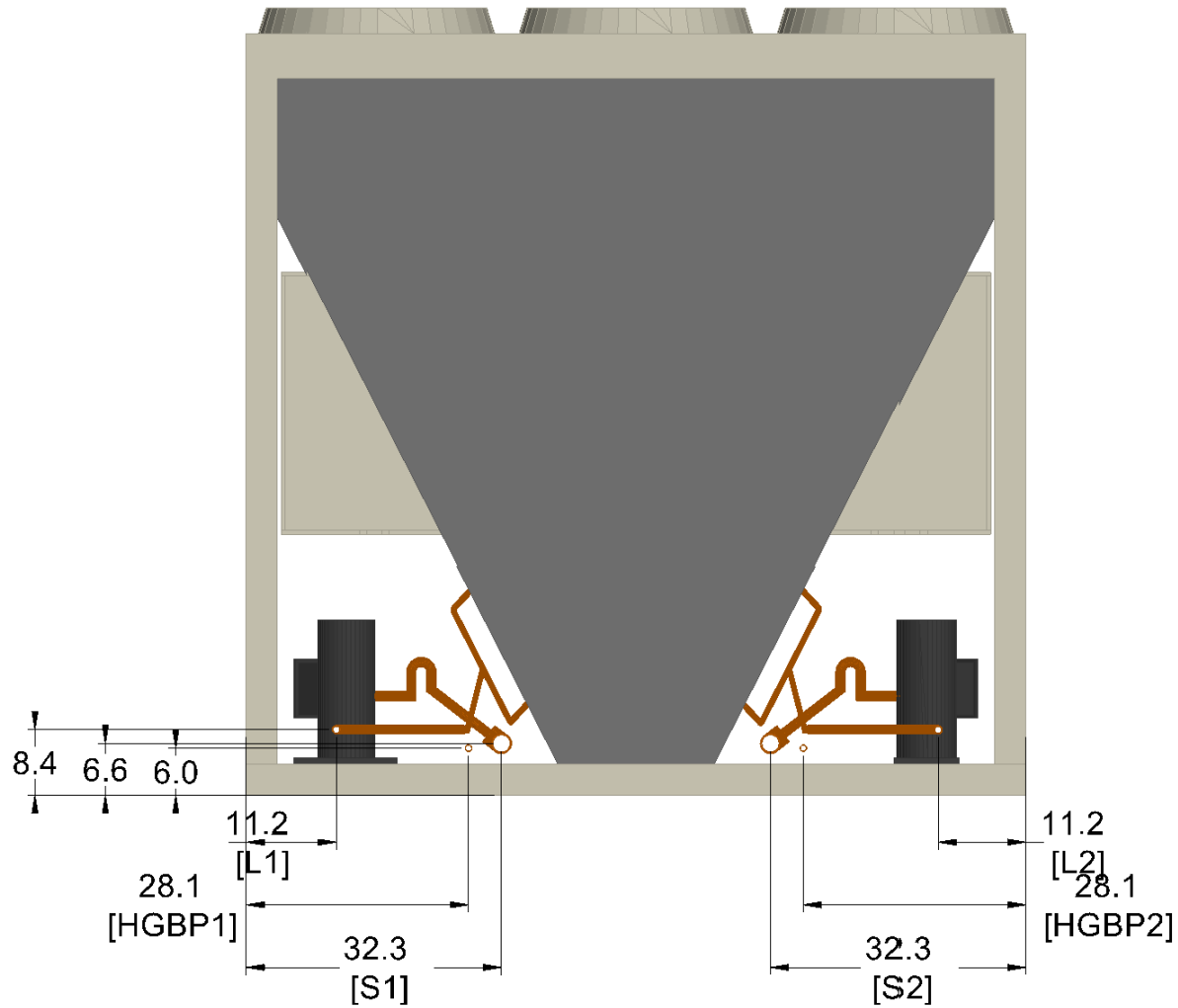

ELEVATION VIEW - PIPE CONNECTION DETAILS

Product Drawing	Unit Tag: CU-1 (AHU-1)	Sales Office: HTS Engineering Ltd.				 13600 Industrial Park Blvd. Minneapolis, MN 55441 www.DaikinApplied.com Software Version: 11.60
Product:	Project Name: 22600705 - DCDSB	Sales Engineer:				
Model: RCS100D	Apr. 01, 2026	Ver/Rev:	Sheet: 1 of 1	Scale: NTS	Tolerance: +/- 0.25" Dwg Units: in [mm]	

No change to this drawing may be made unless approved in writing by Daikin Applied. Purchaser must determine that the equipment is fit and sufficient for the job specifications.

Job Information		Technical Data Sheet
Job Name	22600705 - DCDSB Archbishop Dennis Oconnor	
Date	4/1/2026	
Submitted By	Terry Loyala	
Software Version	11.60	
Unit Tag	CU-2 (AHU-2)	



Unit Overview						
Model Number	Voltage V/Hz/Phase	Total Refrigeration Effect Btu/hr	Total Unit Power kW	EER AHRI Conditions	IEER AHRI Conditions	ASHRAE 90.1
RCS025D	575/60/3	289124	24.8	11.0	13.6	2013 Compliant

Physical			
Dimensions and Weight			
Length	Height	Width	Operating Weight
58.0 in	55.5 in	99.0 in	1853 lb
Connections			
Connection	Connection Sizes		
Suction Line Circuit	(2) 1.62 in.		
Liquid Line Circuit	(2) 0.88 in.		
Hot Gas Bypass Circuit	(2) 0.88 in.		

Electrical					
Voltage	MROPD	Field Power Connection	MCA	SCCR	Field Outlet Connection
575/60/3 V/Hz/Phase	50 A	Thru-the-door disconnect switch	39.3 A	10 kAIC	115V, 20 amp service
Note:	Use only copper supply wires with ampacity based on 75° C conductor rating. Connections to terminals must be made with copper lugs and copper wire.				

Unit		
Model Number:	RCS025D	
Type:	Applied	
Approval:	ETL - Canada	
Refrigerant Type:	No. of Refrigerant Circuits	Refrigerant Weight
R410A	2	16.6 lb

Condensing Section

Temperature		Altitude	Refrigeration Effect	Power
Suction	Ambient			
45.0 °F	95.0 °F	0 ft	289124 Btu/hr	24.8 kW

Compressor

Quantity	Type	Capacity Control	Compressor Isolation
3	Scroll	4 steps	Resilient

Full Load Current:

Compressor 1	16.0 A
Compressor 2	7.7 A
Compressor 4	7.7 A

Condenser

Type	Coil		Fans	Fan Motors	
	Number of Rows	Fins per Inch	Condenser Fan Type	Quantity	Full Load Current
Aluminum tube micro channel	1	18	Standard	2	1.70 A

Sound

Casing Radiated Sound Power (db)

63 Hz	125 Hz	250 Hz	500 Hz	1 kHz	2 kHz	4 kHz	8 kHz
0	91	88	86	86	83	80	79

Options

Unit

Hot Gas Bypass:	HGBP Tee (See Accessory Tab)
Condenser Coil Options:	Condenser with built in hail protection

Electrical

Field Connection	Thru-the-door disconnect switch
Wiring Options	Sealtite conduit
GFI Receptacle	Field powered

Unit Control

Temperature Controls:	No temp control, 115 V transformer
Low Ambient Control:	Fantrol, Low ambient control to 45 degrees

Warranty

Parts:	Standard one year parts
Compressor:	Standard one year compressor

2-YEAR

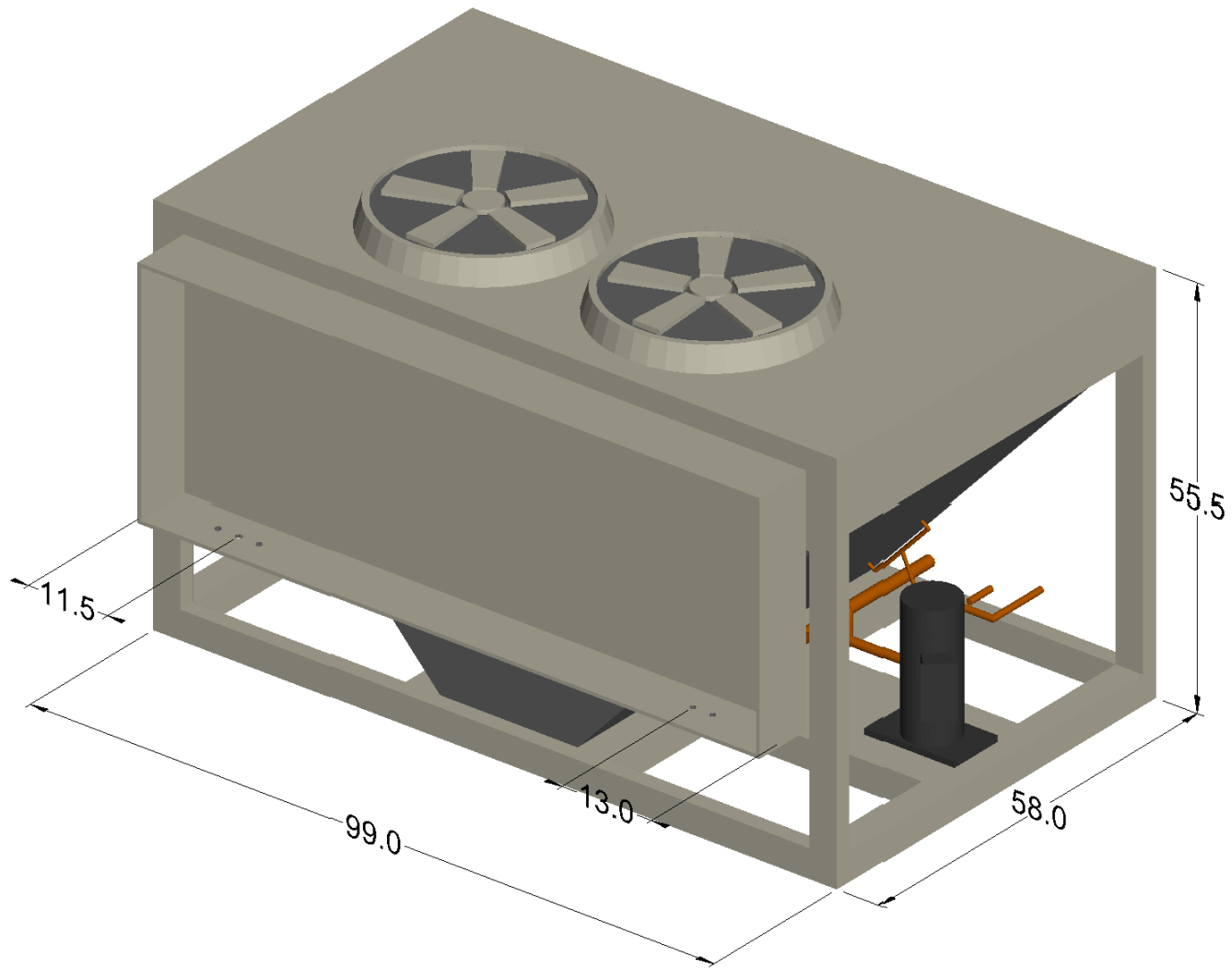

Product Drawing

Product:

Model: RCS025D

Unit Tag: CU-2 (AHU-2)

Project Name: 22600705 - DCDSB

Apr. 01, 2026

Ver/Rev:

Sheet: 1 of 1

Sales Office: HTS Engineering Ltd.

Sales Engineer:

Scale: NTS

Tolerance: +/- 0.25"

Dwg Units: in [mm]



13600 Industrial Park Blvd. Minneapolis, MN 55441
www.DaikinApplied.com Software Version: 11.60

No change to this drawing may be made unless approved in writing by Daikin Applied. Purchaser must determine that the equipment is fit and sufficient for the job specifications.

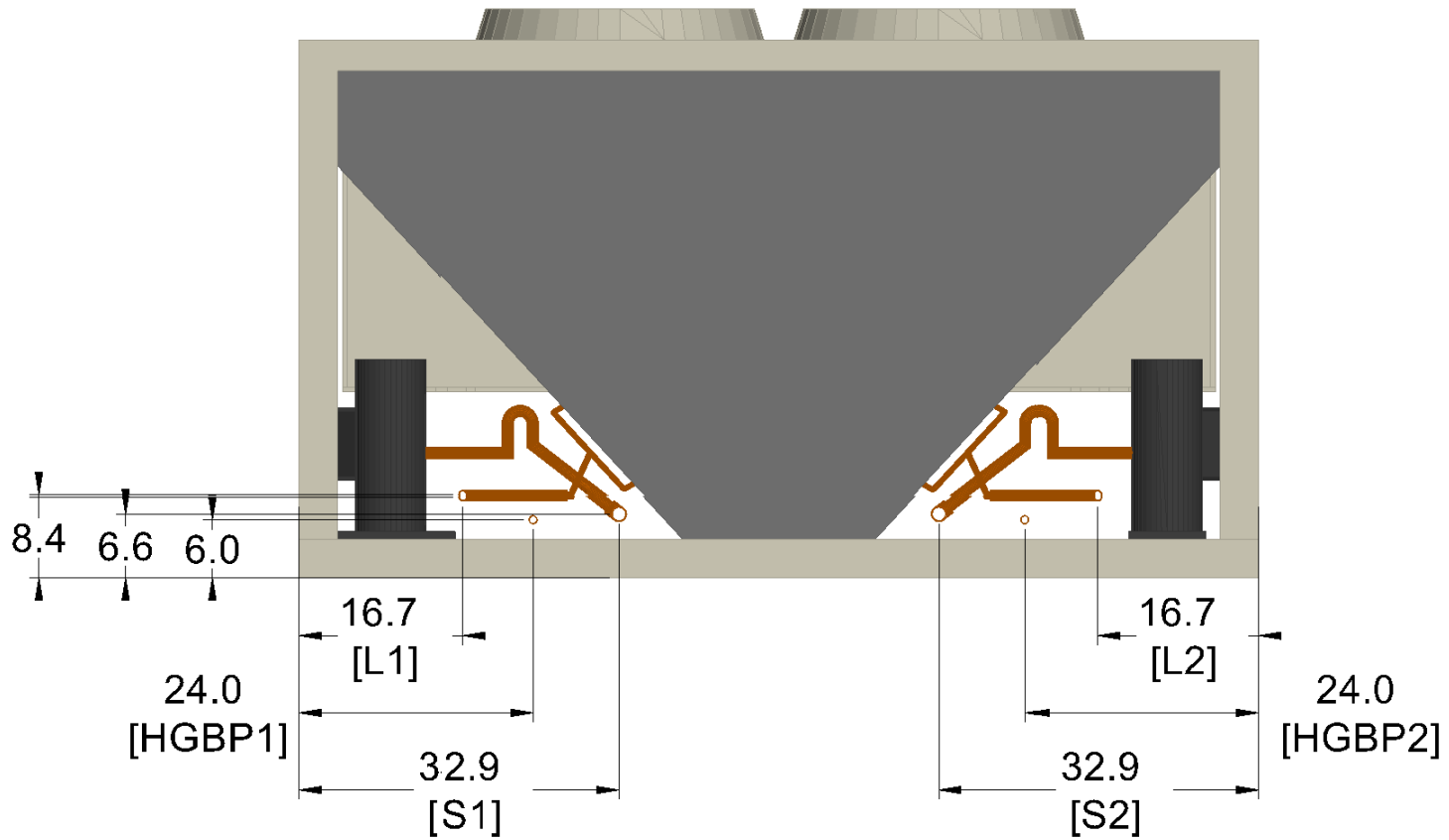

ELEVATION VIEW - PIPE CONNECTION DETAILS

Product Drawing	Unit Tag: CU-2 (AHU-2)	Sales Office: HTS Engineering Ltd.				 13600 Industrial Park Blvd. Minneapolis, MN 55441 www.DaikinApplied.com Software Version: 11.60
Product:	Project Name: 22600705 - DCDSB	Sales Engineer:				
Model: RCS025D	Apr. 01, 2026	Ver/Rev:	Sheet: 1 of 1	Scale: NTS	Tolerance: +/- 0.25" Dwg Units: in [mm]	

No change to this drawing may be made unless approved in writing by Daikin Applied. Purchaser must determine that the equipment is fit and sufficient for the job specifications.

Job Information		Technical Data Sheet
Job Name	22600705 - DCDSB Archbishop Dennis Oconnor	
Date	4/1/2026	
Submitted By	Terry Loyala	
Software Version	11.60	
Unit Tag	CU-3 (AHU-3)	



Unit Overview						
Model Number	Voltage V/Hz/Phase	Total Refrigeration Effect Btu/hr	Total Unit Power kW	EER AHRI Conditions	IEER AHRI Conditions	ASHRAE 90.1
RCS050D	575/60/3	596814	47.5	11.0	15.3	2013 Compliant

Physical			
Dimensions and Weight			
Length	Height	Width	Operating Weight
80.0 in	73.0 in	99.0 in	2449 lb
Connections			
Connection	Connection Sizes		
Suction Line Circuit	(2) 1.62 in.		
Liquid Line Circuit	(2) 0.88 in.		
Hot Gas Bypass Circuit	(2) 0.88 in.		

Electrical					
Voltage	MROPD	Field Power Connection	MCA	SCCR	Field Outlet Connection
575/60/3 V/Hz/Phase	90 A	Single power block	75.8 A	10 kAIC	115V, 20 amp service
Note:	Use only copper supply wires with ampacity based on 75° C conductor rating. Connections to terminals must be made with copper lugs and copper wire.				

Unit		
Model Number:	RCS050D	
Type:	Applied	
Approval:	ETL - Canada	
Refrigerant Type:	No. of Refrigerant Circuits	Refrigerant Weight
R410A	2	24.4 lb

Condensing Section

Temperature		Altitude	Refrigeration Effect	Power
Suction	Ambient			
45.0 °F	90.0 °F	0 ft	596814 Btu/hr	47.5 kW

Compressor

Quantity	Type	Capacity Control	Compressor Isolation
4	Scroll	4 steps	Resilient

Full Load Current:

Compressor 1	16.0 A
Compressor 2	16.0 A
Compressor 3	16.0 A
Compressor 4	16.0 A

Condenser

Type	Coil		Fans	Fan Motors	
	Number of Rows	Fins per Inch	Condenser Fan Type	Quantity	Full Load Current
Aluminum tube micro channel	1	18	Standard	4	1.70 A

Sound

Casing Radiated Sound Power (db)

63 Hz	125 Hz	250 Hz	500 Hz	1 kHz	2 kHz	4 kHz	8 kHz
0	94	91	89	89	86	83	82

Options

Unit

Hot Gas Bypass:	HGBP Tee (See Accessory Tab)
Condenser Coil Options:	Condenser with built in hail protection

Electrical

Electrical Options:	Phase failure
Field Connection	Single power block
Wiring Options	Sealtite conduit
GFI Receptacle	Field powered

Unit Control

Temperature Controls:	No temp control, 115 V transformer
Low Ambient Control:	Fantrol, Low ambient control to 45 degrees

Warranty

Parts:	Standard one year parts
Compressor:	Standard one year compressor

2-YEAR

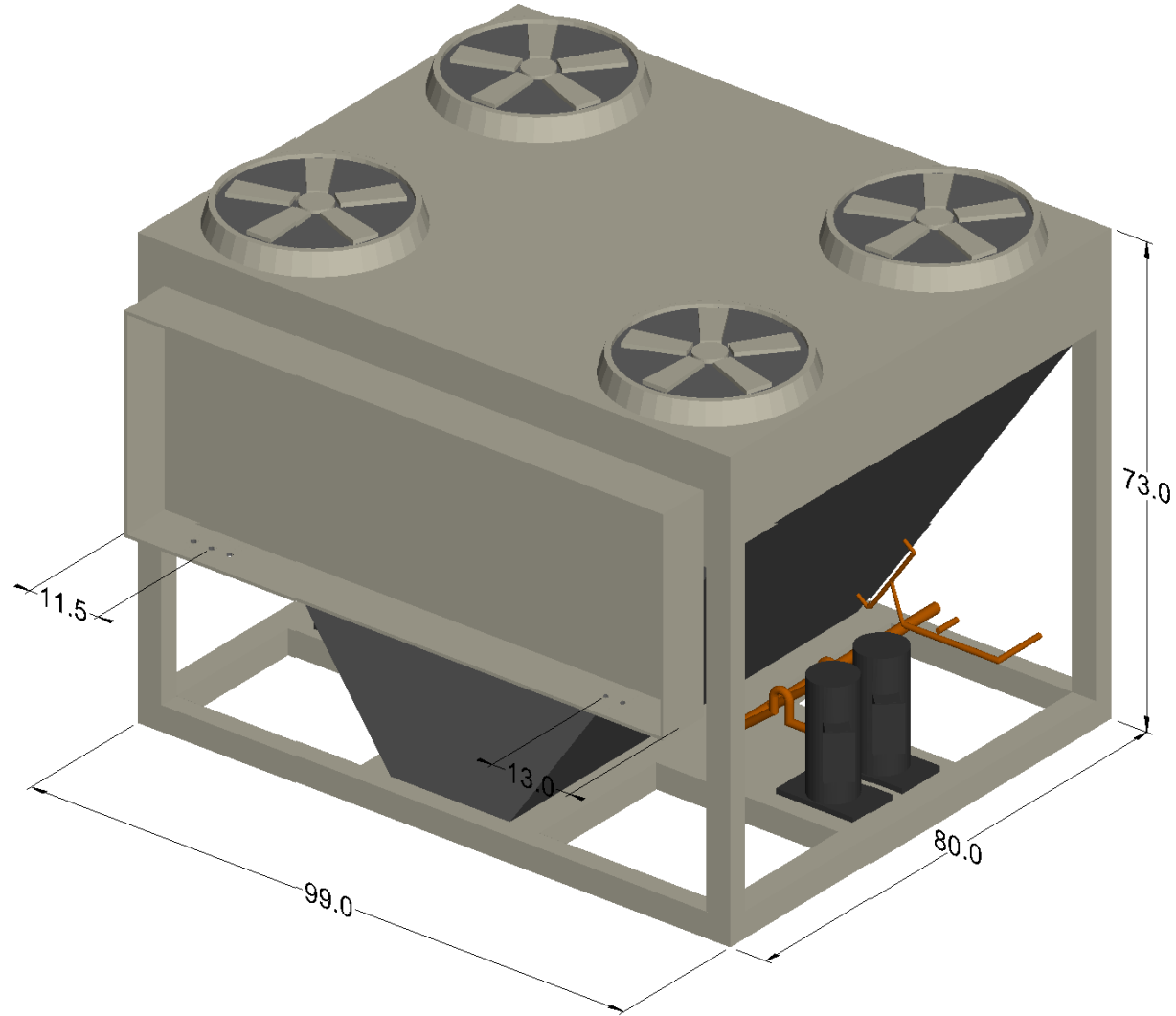

Product Drawing	Unit Tag: CU-3 (AHU-3)	Sales Office: HTS Engineering Ltd.				 13600 Industrial Park Blvd. Minneapolis, MN 55441 www.DaikinApplied.com Software Version: 11.60
Product:	Project Name: 22600705 - DCDSB	Sales Engineer:				
Model: RCS050D	Apr. 01, 2026	Ver/Rev:	Sheet: 1 of 1	Scale: NTS	Tolerance: +/- 0.25" Dwg Units: in [mm]	

No change to this drawing may be made unless approved in writing by Daikin Applied. Purchaser must determine that the equipment is fit and sufficient for the job specifications.

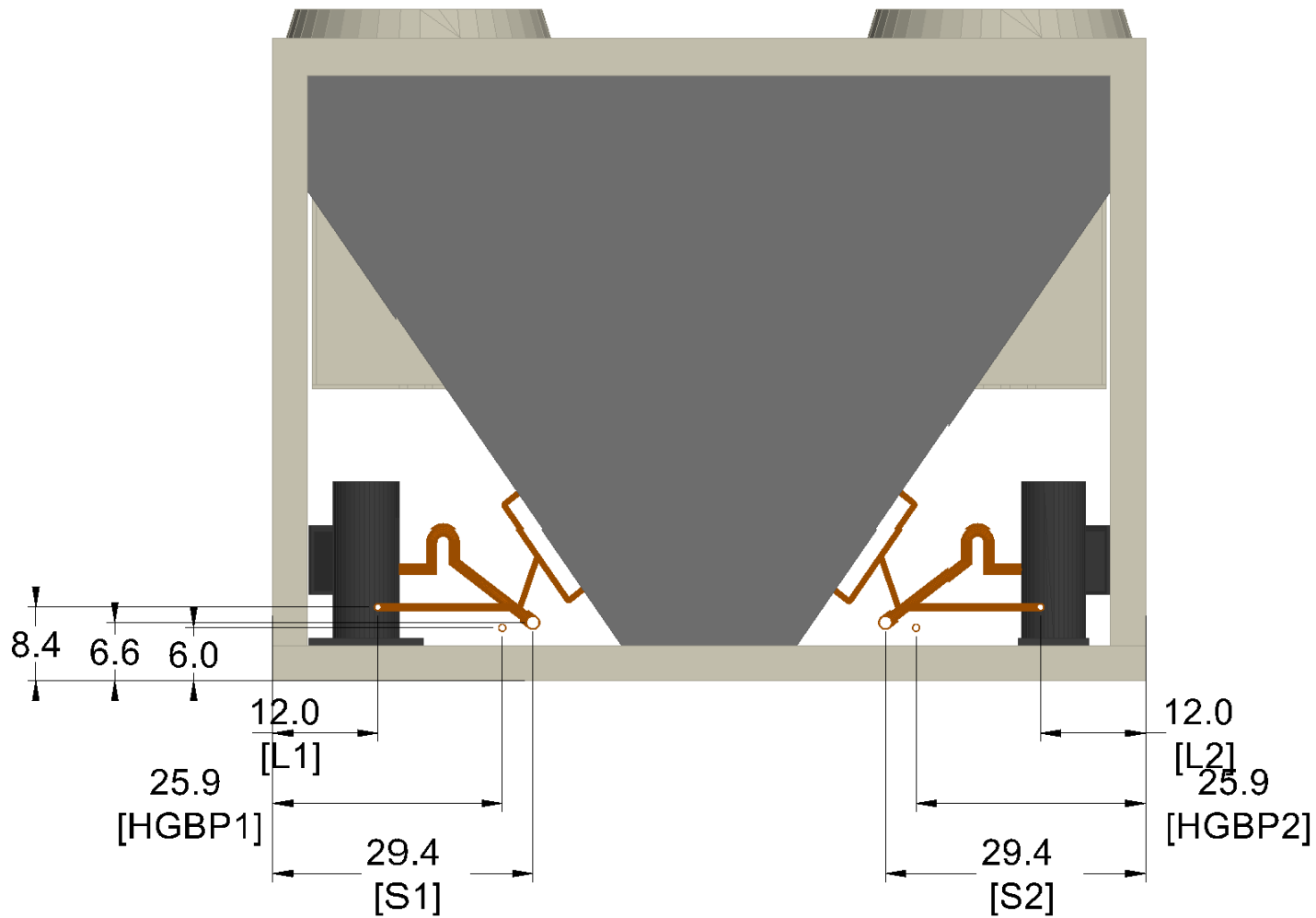

ELEVATION VIEW - PIPE CONNECTION DETAILS

Product Drawing	Unit Tag: CU-3 (AHU-3)	Sales Office: HTS Engineering Ltd.				 13600 Industrial Park Blvd. Minneapolis, MN 55441 www.DaikinApplied.com Software Version: 11.60
Product:	Project Name: 22600705 - DCDSB	Sales Engineer:				
Model: RCS050D	Apr. 01, 2026	Ver/Rev:	Sheet: 1 of 1	Scale: NTS	Tolerance: +/- 0.25" Dwg Units: in [mm]	

No change to this drawing may be made unless approved in writing by Daikin Applied. Purchaser must determine that the equipment is fit and sufficient for the job specifications.



HTS Oshawa

2001 Thickson Rd, South
Unit #11
Whitby, ON L1N 6J3
T 905.579.6700
F 905.597.5290

ontario.htseng.com

SUBMITTAL DATA
APPROVAL REQUIRED

IOM LINK

https://htseng-my.sharepoint.com/:f:/g/personal/curtis_metrow_hts_com/IgD_JwPmhDmwQZINhdRqf-csAWEu08nbwsg2MnbpeWdmLds?e=AVpGVC



Submittal # 98430

APPROVAL REQUIRED

Project 22600705-OWN-1- DCDSB - Archbishop Denis O'Connor
Leader Curtis Metrow
Job Site 80 Mandrake St, Ajax, ON, Canada
Submission Date 2026-04-20
Sold To DURHAM CDSB *
Submitted By Curtis Metrow

Contacts

Role	Customer	Our Rep
Owner	Durham Catholic District School Board *	Curtis Metrow
Designer	Ellard Willson Engineering	Steve Cukrovani

Deliverables

Track #	335955	
Tag	ERV-1 (AHU-1), ERV-2 (AHU-2)	
Description	Advanced Series	
Quantity	2	
Manufacturer	ALDES	
Specification		
Production Lead Time	12 - 14 Weeks	
Revision #	1	

Attention:

- 1) HTS will provide equipment in accordance with the attached shop drawings.
- 2) Upon approved submittal and customer release, HTS will release equipment to fabrication per the published lead times. Any storage fees associated with project schedule changes will be the responsibility of the purchaser.
- 3) HTS can provide freight and logistics to the purchaser as an added benefit of doing business with HTS. When freight is received by the purchaser, any noticeable damage must be recorded. Otherwise, HTS is not responsible for subsequent damage claims.

Approval Stamps

RYBKA ELLARD WILLSON INC

- REVIEWED**
- REVIEWED AS NOTED**
- REVISE AND RESUBMIT**



SUBMITTAL WAS REVIEWED FOR DESIGN CONFORMITY AND GENERAL CONFORMANCE TO CONTRACT DOCUMENTS ONLY. THE CONTRACTOR IS RESPONSIBLE FOR CONFIRMING AND CORRELATING DIMENSIONS AT JOB SITES FOR TOLERANCES, CLEARANCES, QUANTITIES, FABRICATION PROCESSES AND TECHNIQUES OF CONSTRUCTION, COORDINATION OF THEIR WORK WITH OTHER TRADES AND FULL COMPLIANCE WITH THE CONTRACT DOCUMENTS.

BY JMACQUARRIE

DATE 2026/4/20

RYBKA ELLARD WILLSON INC

- REVIEWED**
- REVIEWED AS NOTED**
- REVISE AND RESUBMIT**



SUBMITTAL WAS REVIEWED FOR DESIGN CONFORMITY AND GENERAL CONFORMANCE TO CONTRACT DOCUMENTS ONLY. THE CONTRACTOR IS RESPONSIBLE FOR CONFIRMING AND CORRELATING DIMENSIONS AT JOB SITES FOR TOLERANCES, CLEARANCES, QUANTITIES, FABRICATION PROCESSES AND TECHNIQUES OF CONSTRUCTION, COORDINATION OF THEIR WORK WITH OTHER TRADES AND FULL COMPLIANCE WITH THE CONTRACT DOCUMENTS.

BY FCHANG

DATE 4/20/2026



HTS Oshawa

2001 Thickson Rd, South
Unit #11
Whitby, ON L1N 6J3
T 905.579.6700
F 905.597.5290

ontario.htseng.com

SUBMITTAL DATA
APPROVAL REQUIRED

ROOF MOUNTED ENERGY RECOVERY VENTILATOR

ERV-1,2

Technical Information And Drawings

Notes:

- 1) Electrical:
 - a. A single 575/3/60 electrical feed is required per unit
 - i. ERV-1 MCA = 37.0 / MOCP = 45
 - ii. ERV-2 MCA = 16.25 / MOCP = 20
 - b. Main non-fused disconnect is provided
- 2) Unit Options:
 - a. Energy recovery wheel
 - b. Filter rack – 4” MERV 8 filter on supply and exhaust
 - c. Exhaust/Supply fans with VFDs
 - d. Horizontal supply and return connections
 - e. 14” insulated roof curb
- 3) Controls
 - a. Integral unit controller complete with integral operators LCD – password controlled
 - b. BMS integration via BACnet MSTP
- 4) Assembly Info:
 - a. Ships in single piece with loose exhaust and fresh air hoods for field installation
- 5) Warranty
 - a. 2 year factory parts warranty included

Customer Name	HTS Engineering Ltd
Project Name	DCSB Archbishop Dennis O'Connor - 22600705
Unit Tag	ERV-1
Created By	Fanilo Andriaminahy
Date	17042026
Contact Name	
Project No	AC26000200-5
Project Rev	5
Unit No	CW10000e-AC26000200-5-2
Unit Revision	5

Make sure you complete, check and validate the options on the project sheet; before it goes into production. The project will be carried out according to these guidelines. The signing customer is responsible for any missing or erroneous information that may lead to delays and/or additional



Approuvé/Approved
 Refusé/Refused

Par/By: _____

Date: _____

Commentaires/Comments:

**This project specification must be signed and approved before the unit can be released to production. ** Cette spécification de projet doit être signée et approuvée avant que l'unité ne soit mise en production.



Ventilation Summary

DesignTemperature - Winter

Outdoor air temperature (DB)	-4°F
Outdoor air temperature (WB)	-5°F
Indoor air temperature (DB)	72°F
Indoor air temperature (WB)	54°F

DesignTemperature - Summer

Outdoor air temperature (DB)	90°F
Outdoor air temperature (WB)	73°F
Indoor air temperature (DB)	75°F
Indoor air temperature (WB)	63°F

Fresh Air circuit

Air flow	11000 CFM
External static Pressure	1in H2O
Rotational speed	1024 RPM

Exhaust Air circuit

Air flow	11000 CFM
External static Pressure	1 in H2O
Rotational speed	1025 RPM

Heating Capacity

Recovered energy	797.1 MBH
Heating Capacity	0 MBH
Sensible Efficiency	71.49 %
Latent Efficiency	66.81 %
Total Efficiency	70.36 %

Cooling Capacity

Recovered energy	22.6 Tons
Cooling Capacity	N/A Tons
Sensible Efficiency	70.07 %
Latent Efficiency	65.98 %
Total Efficiency	67.92 %

Supply Temperature - Winter

Supply air temperature (DB)	48° F
Supply air temperature (WB)	40 °F

Supply Temperature - Summer

Supply air temperature (DB)	79 °F
Supply air temperature (WB)	66 °F

Electrical Load

Fresh Air Motor

Power	15 HP
Motor's Voltage	575/3/60
FLA	14.1 A
Rotational speed	1800 RPM
Starter	VFD

Exhaust Air Motor

Power	15 HP
Motor's Voltage	575/3/60
FLA	14.1 A
Rotational speed	1800 RPM
Starter	VFD

Unit Voltage

	Main Disc	Disc #2	Disc #3	Disc Int.
Voltage	575/3/60	575/3/60	575/3/60	120/1/60
FLA	29.6	0	0	0
MCA	37	0	0	0
MOP	45	0	0	0

Motor for the wheel

Power	0.25 HP
Motor's Voltage	575/3/60
FLA	1.4 A
Rotational speed	1800 RPM

Cabinet

Cabinet type	Double-wall
Exterior sheet metal Gauge	22 ga prepaint steel
Interior sheet metal Gauge	18 ga galvanized steel
Access	Doors with quarter-turn handles
Insulation	2 in
Duct Configuration	Horizontal



Outdoor installation

Mount	14 in Insulated Roof Curb
-------	---------------------------

Fresh Air Blower

Type	Forward-curved
Bearing	Pillow-block
Width	18 in
Diameter	18 in
Shaft diameter	1.4375 in
Drive	Power transmission by adjustable pulleys and belts

Exhaust Air Blower

Type	Forward-curved
Bearing	Pillow-block
Width	18 in
Diameter	18 in
Shaft diameter	1.4375 in
Drive	Power transmission by adjustable pulleys and belts

Fresh Air Motor

Power	15 HP
Type	ODP, Inverter Ready
Efficiency	PREMIUM
Frame	254T
Speed(s)	1
Mount	Spring Isolators

Exhaust Air Motor

Power	15 HP
Type	ODP, Inverter Ready
Efficiency	PREMIUM
Frame	254T
Speed(s)	1
Mount	Spring Isolators

Fresh Air Filters

Type	MERV8
Quantity per circuit	8
Dimensions	20 x 20 x 4in

Exhaust Air Filters

Type	MERV8
Quantity per circuit	8
Dimensions	20 x 20 x 4in

Heat exchanger

Quantity	1
Type	Enthalpique Roue
Dimensions	
Spacing	

Warranty

Core	2 years limited
Unit	2 years limited

Certification



CSA 22,2 No,236-11
 UL 1995

Unit's general dimensions

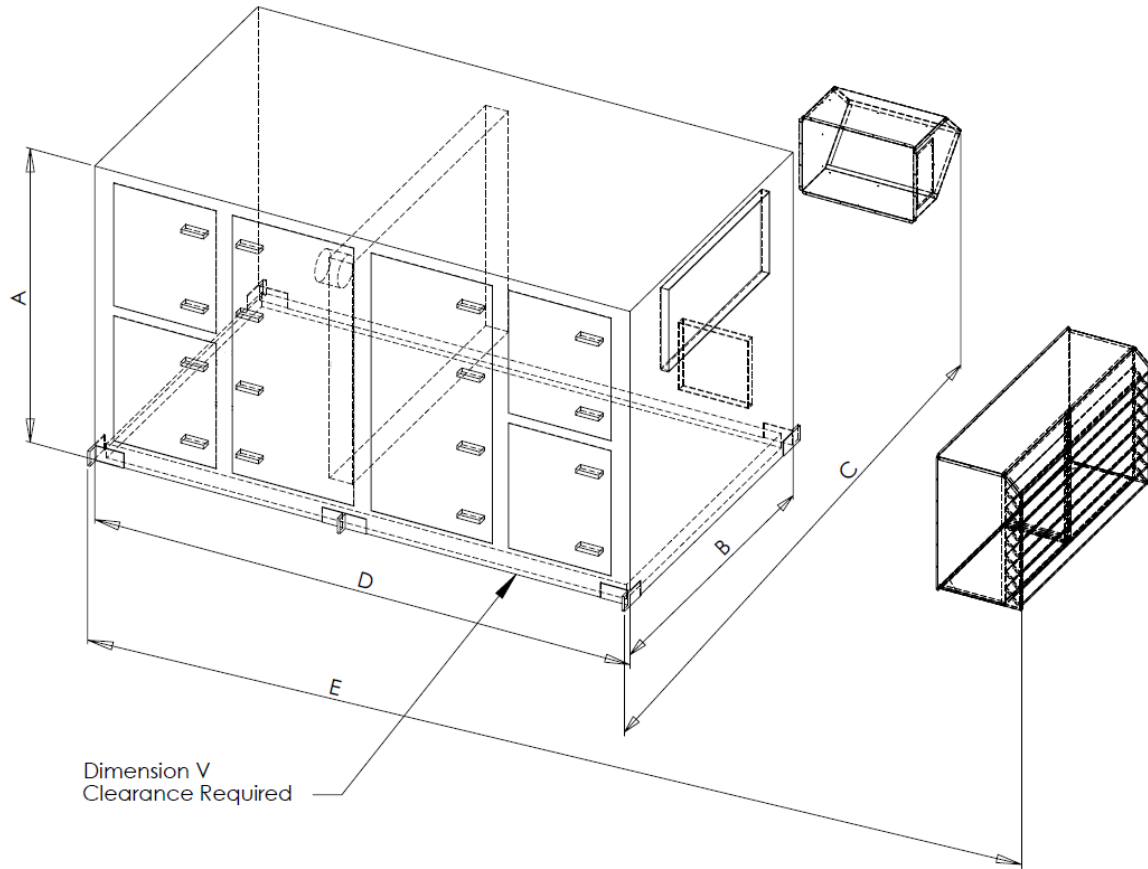

Cabinet dimensions (In)

A	B	C	D	E	V
95.84	92.53	121.29	121.34	150.31	87

Estimated unit weight: 4600 lb

Horizontal Duct Configuration

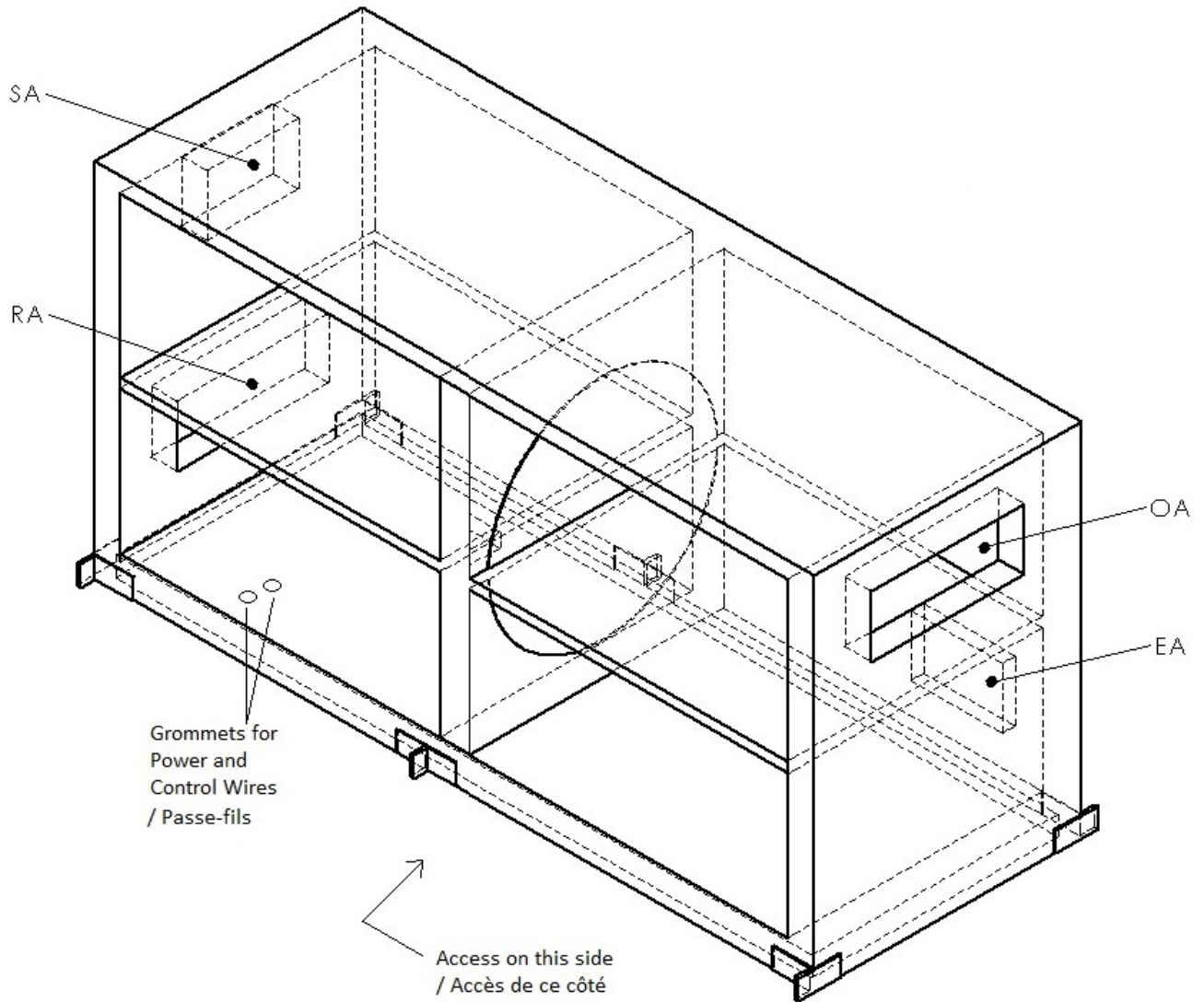

Duct opening dimensions (in)

	Width	Height
OA	56	28
SA	24	22
RA	56	28
EA	24	22

Roof Curb

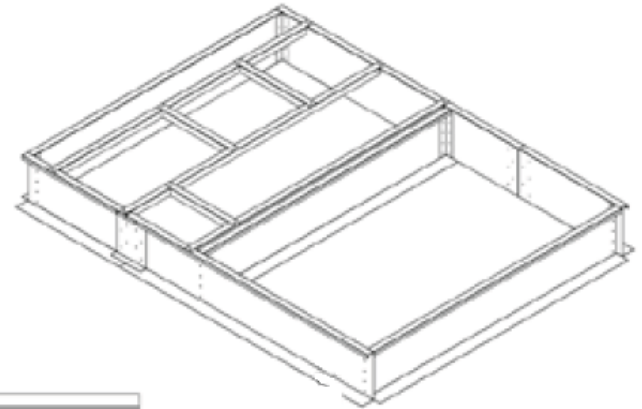
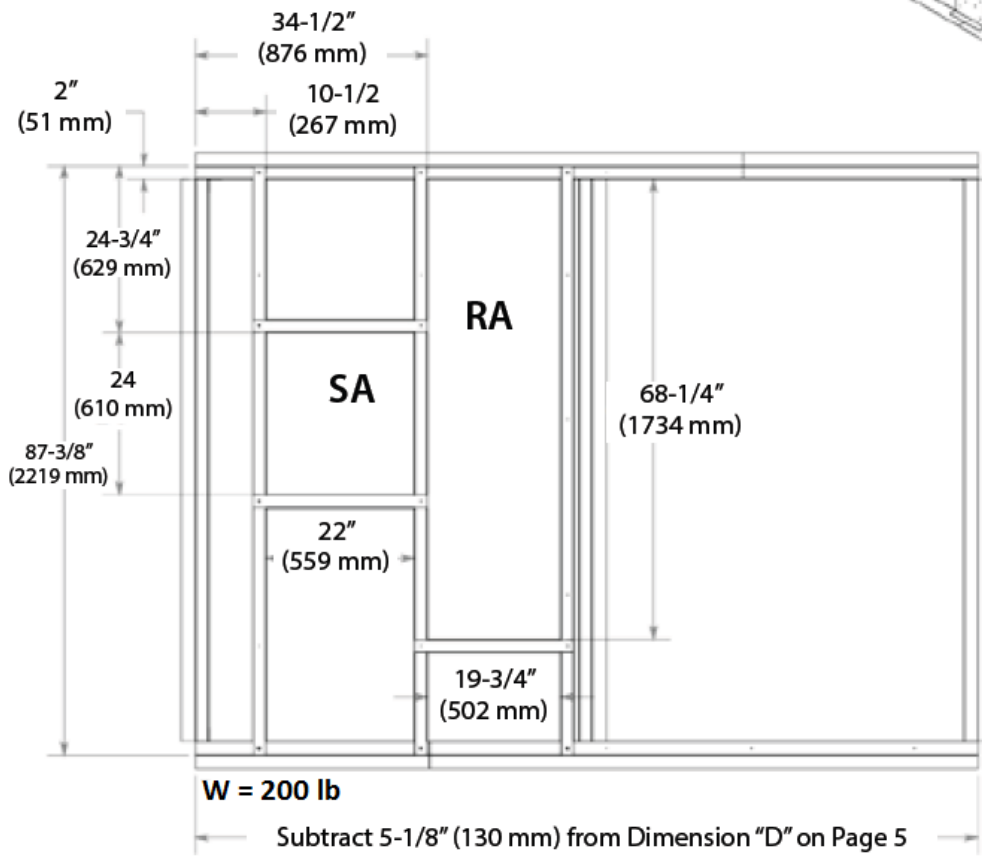

Note: The roof curb in the image does not necessarily represent the unit's configuration.

Unit Controls

- 24VAC, 20 VA power : Power supply 24VAC 20VA for external accessories
- Remote keypad and display : Gives the ability to monitor and set the unit remotely (with a wire connection).
- General Alarm dry contact : When the unit goes into alarm mode, a dry contact (NO) is closed.
- Start/Stop dry contact : The state of the unit (Start/stop) is controlled via a normally open (NO) dry contact.
- BACnet communication module - BACnet MS/TP : BACnet MS/TP connection port. The controller will communicate via a BACnet MS/TP link with the BMS.
- Low airflow switch : Opening of a dry contact (NC) when no airflow is detected on supply blower
- Dirty filters contacts : Will close a dry contact when dirty filters are detected
- Terminal boards for exhaust air damper : Power and control (24VAC, 10VA) for the exhaust air damper (internal or external to the unit).
- Terminal boards for fresh air damper : Power and control (24VAC, 10VA) for the fresh air damper (internal or external to the unit).
- Occupancy control dry contact : The state of the unit (Start/stop) is controlled via a normally open (NO) dry contact.
- BacNet compatible controller : Unit is equipped with a BACnet compatible controller.
- Phase loss detection : Unit will stop when a phase loss occurs, automatic restart
- Wheel rotation detection : A dry contact is closed if no rotation is detected
- Fan interlock on OA : Dry contact (NO) that closes when the fresh air motor is started.
- End switch on dampers : Unit start conditionally to dampers opening

- Free Cooling dry contact : The Unit will go into free cooling mode when a dry contact (NO) is closed.
- Non-fused disconnect : The unit will be equipped with a Non-fused disconnect.

Components

- Hood on exhaust air : Hood covering the exhaust air discharge against weather element, protected with 3/8" bird screen.
- Hood on outside air intake : Hood covering the outside air intake against weather element, protected with 3/8" bird screen.
- MERV8 filters on EA : MERV8 filter rack in the exhaust air circuit.
- MERV8 filters on OA : MERV8 filter rack in the fresh air circuit.
- Prepainted exterior wall : Exterior wall galvanized steel is replaced with prepainted steel.
- Insulated Roof curb : of 14 in. high in 18 ga galvanized steel
- VFD on exhaust air motor : The exhaust air motor is controlled by a VFD installed inside the unit and powered by the unit. The 0-10VDC signal is by others.
- VFD on supply air motor : The fresh air motor is controlled by a VFD installed inside the unit and powered by the unit. The 0-10VDC signal is by others.
- Wheel speed variation (VFD) : The unit monitors the exhaust air temperature and modulate the wheel speed in order to maintain it above freezing. Note : Wheel performance does not include frost control and actual supply air temperature may be lower.
- Exhaust air motorized and insulated dampers : Motorized and insulated damper on exhaust air opening actuated with a two positions (spring return) actuator.
- Fresh air motorized and insulated dampers : Motorized and insulated damper on fresh air opening actuated with a two positions (spring return) actuator.
- Horizontal duct configuration
- (1) in S40 for Exhaust Air and frost management

Frost control

- Wheel speed variation (VFD) : The unit monitors the exhaust air temperature and modulate the wheel speed in order to maintain it above freezing. Note : Wheel performance does not include frost control and actual supply air temperature may be lower.

Custom Options

- Vented control panel to dissipate heat generated from VFDs
- Heated control panel to prevent frost

Wheel Performance

Model	Enthalpique Roue
Diameter	74 in
Spacing	0.25 hp

	Entering Fresh Air T1		Leaving Fresh Air T2	
	Summer	Winter	Summer	Winter
Net Air Flow (CFM)			11000	11000
Real Air Flow (CFM)	11536	11536	11262	11262
Temperature Dry Bulb (°F)	90	-4	79	48
Temperature Wet Bulb (°F)	73	-5	66	40
Relative humidity (%)	44.77	64.08	44.9	50.7
Enthalpy (BTU/lb)	36.5	-0.4	31	15.1
Capacity				

	Leaving Exhaust Air T4		Entering Exhaust Air T3	
	Summer	Winter	Summer	Winter
Air Flow (CFM)			11000	11000
Real Air Flow (CFM)	11536	11536	11262	11262
Temperature Dry Bulb (°F)	86	17	75	72
Temperature Wet Bulb (°F)	70	17	63	72
Relative humidity (%)	46.5	96.2	51.6	28.74
Enthalpy (BTU/lb)	33.9	6.1	28.4	22.5
Capacity				

Performance

	Summer	Winter
Fresh Air Pressure Drop (in H ₂ O)	1.18	1.18
Exhaust Air Pressure Drop (in H ₂ O)	1.17	1.17
Sensible Efficiency (%)	70.07	71.49
Latent Efficiency (%)	65.98	66.81
Total Efficiency (%)	67.92	70.36
Recovered energy (Tonnes)	22.6	
Recovered energy (MBH)		797.1
EATR	2.3	2.3
OACF	1	1

Fresh Air Blower Performance

Information

Air flow	11262 CFM	Shaft Diameter	1.4375 in
Total Static Pressure	2.74 in H ₂ O	Static Efficiency	42.68 %
Rotation Speed	1024 RPM	Elevation	0 ft
Power	11.36 HP	Temperature	70 °F

Sound data

	63	125	250	500	1000	2000	4000	8000	(Hz)	LwA: 94
Sound Power Level @ Frequency, re: 10 ⁻¹² Watts	90	97	94	90	88	85	84	79	(dB)	Sones:39

Exhaust Air Blower Performance

Information

Air flow	11536 CFM	Shaft Diameter	1.4375 in
Total Static Pressure	2.7 in H ₂ O	Static Efficiency	41.63 %
Rotation Speed	1025 RPM	Elevation	0 ft
Power	11.79 HP	Temperature	70 °F

Sound data

	63	125	250	500	1000	2000	4000	8000	(Hz)	LwA: 94
Sound Power Level @ Frequency, re: 10 ⁻¹² Watts	90	97	94	91	88	85	84	79	(dB)	Sones:40

Coil specifications

Important notes

Customer Name	HTS Engineering Ltd
Project Name	DCSB Archbishop Dennis O'Connor - 22600705
Unit Tag	ERV-2
Created By	Fanilo Andriaminahy
Date	17042026
Contact Name	
Project No	AC26000200-5
Project Rev	5
Unit No	CW5000e-AC26000200-5-1
Unit Revision	5

Make sure you complete, check and validate the options on the project sheet; before it goes into production. The project will be carried out according to these guidelines. The signing customer is responsible for any missing or erroneous information that may lead to delays and/or additional



Approuvé/Approved
 Refusé/Refused

Par/By: _____

Date: _____

Commentaires/Comments:

**This project specification must be signed and approved before the unit can be released to production. ** Cette spécification de projet doit être signée et approuvée avant que l'unité ne soit mise en production.



Ventilation Summary

DesignTemperature - Winter

Outdoor air temperature (DB)	-4°F
Outdoor air temperature (WB)	-5°F
Indoor air temperature (DB)	72°F
Indoor air temperature (WB)	54°F

DesignTemperature - Summer

Outdoor air temperature (DB)	90°F
Outdoor air temperature (WB)	73°F
Indoor air temperature (DB)	75°F
Indoor air temperature (WB)	63°F

Fresh Air circuit

Air flow	4250 CFM
External static Pressure	1in H2O
Rotational speed	1087 RPM

Exhaust Air circuit

Air flow	4250 CFM
External static Pressure	1 in H2O
Rotational speed	1111 RPM

Heating Capacity

Recovered energy	330.8 MBH
Heating Capacity	0 MBH
Sensible Efficiency	76.64 %
Latent Efficiency	72.2 %
Total Efficiency	75.57 %

Cooling Capacity

Recovered energy	9.4 Tons
Cooling Capacity	N/A Tons
Sensible Efficiency	75.61 %
Latent Efficiency	71.53 %
Total Efficiency	73.45 %

Supply Temperature - Winter

Supply air temperature (DB)	53° F
Supply air temperature (WB)	43 °F

Supply Temperature - Summer

Supply air temperature (DB)	79 °F
Supply air temperature (WB)	66 °F

Electrical Load

Fresh Air Motor

Power	5 HP
Motor's Voltage	575/3/60
FLA	5.8 A
Rotational speed	1800 RPM
Starter	VFD

Exhaust Air Motor

Power	5 HP
Motor's Voltage	575/3/60
FLA	5.8 A
Rotational speed	1800 RPM
Starter	VFD

Unit Voltage

	Main Disc	Disc #2	Disc #3	Disc Int.
Voltage	575/3/60	575/3/60	575/3/60	120/1/60
FLA	13	0	0	0
MCA	16.25	0	0	0
MOP	20	0	0	0

Motor for the wheel

Power	0.17 HP
Motor's Voltage	575/3/60
FLA	1.4 A
Rotational speed	1800 RPM

Cabinet

Cabinet type	Double-wall
Exterior sheet metal Gauge	22 ga prepaint steel
Interior sheet metal Gauge	18 ga galvanized steel
Access	Doors with quarter-turn handles
Insulation	2 in
Duct Configuration	Horizontal



Outdoor installation

Mount	14 in Insulated Roof Curb
-------	---------------------------

Fresh Air Blower

Type	Forward-curved
Bearing	Pillow-block
Width	10 in
Diameter	15 in
Shaft diameter	1.1875 in
Drive	Power transmission by adjustable pulleys and belts

Exhaust Air Blower

Type	Forward-curved
Bearing	Pillow-block
Width	10 in
Diameter	15 in
Shaft diameter	1.1875 in
Drive	Power transmission by adjustable pulleys and belts

Fresh Air Motor

Power	5 HP
Type	ODP, Inverter Ready
Efficiency	PREMIUM
Frame	184T
Speed(s)	1
Mount	Spring Isolators

Exhaust Air Motor

Power	5 HP
Type	ODP, Inverter Ready
Efficiency	PREMIUM
Frame	184T
Speed(s)	1
Mount	Spring Isolators

Fresh Air Filters

Type	MERV8
Quantity per circuit	6
Dimensions	16 x 20 x 4in

Exhaust Air Filters

Type	MERV8
Quantity per circuit	6
Dimensions	16 x 20 x 4in

Heat exchanger

Quantity	1
Type	Enthalpique Roue
Dimensions	
Spacing	

Warranty

Core	2 years limited
Unit	2 years limited

Certification



CSA 22,2 No,236-11
 UL 1995

Unit's general dimensions

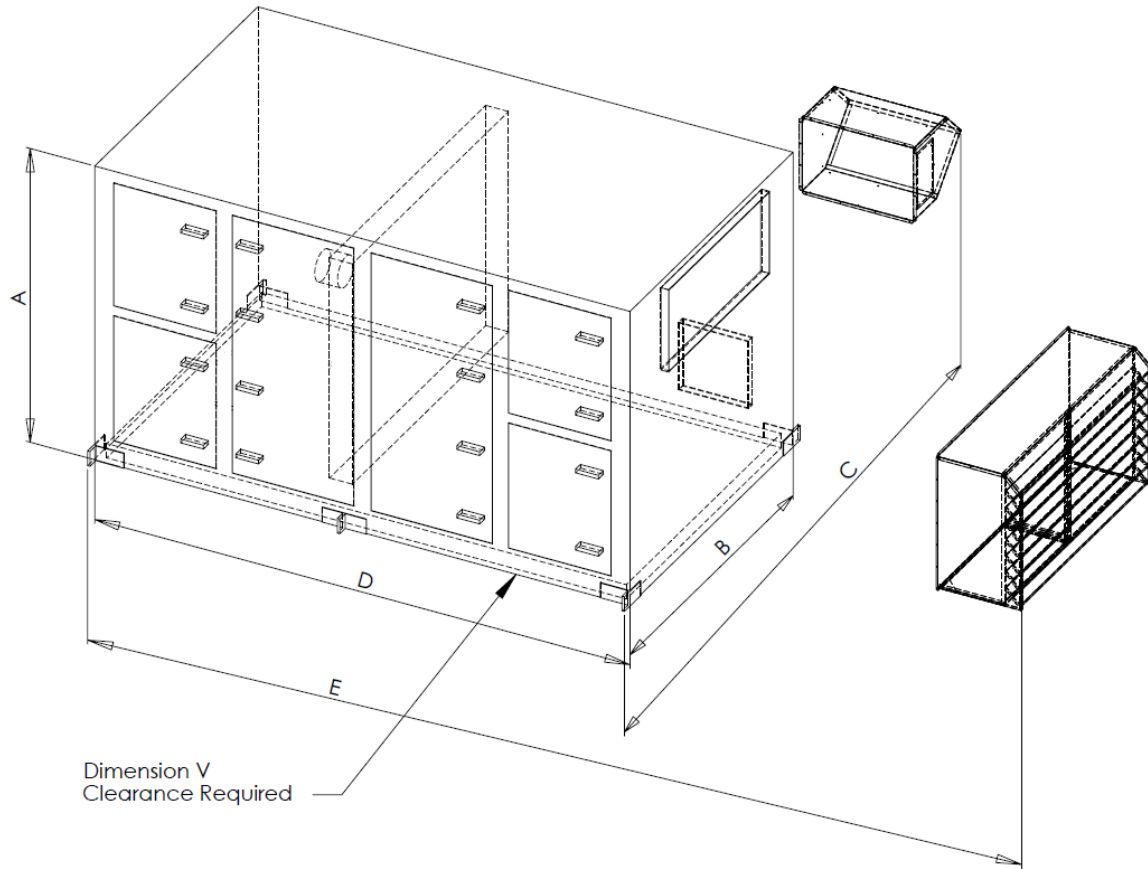

Cabinet dimensions (In)

A	B	C	D	E	V
79.9	69.53	96.3	121.7	146.31	64

Estimated unit weight: 3200 lb

Horizontal Duct Configuration

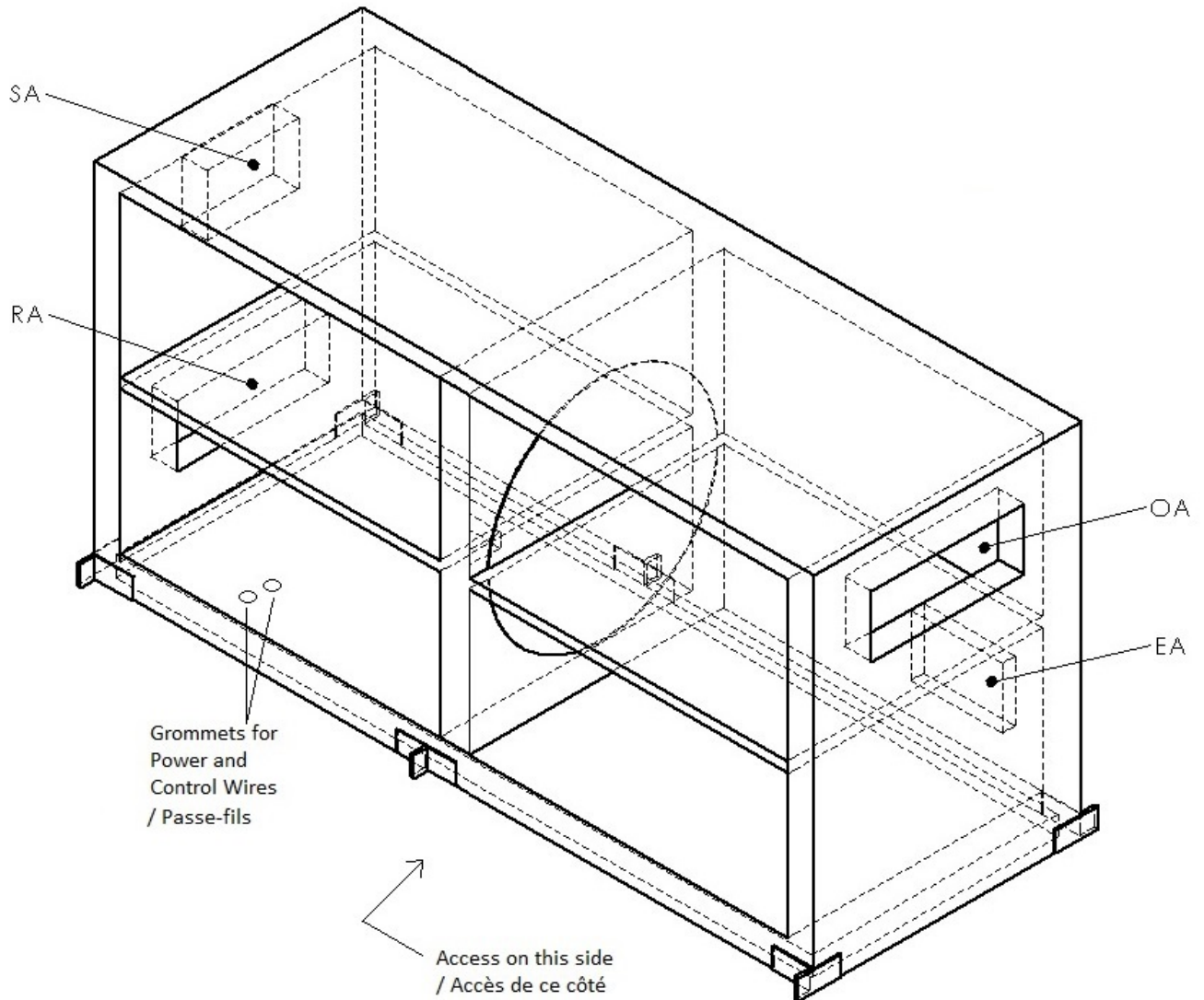

Duct opening dimensions (in)

	Width	Height
OA	40	18
SA	22	18
RA	40	18
EA	22	18

Roof Curb

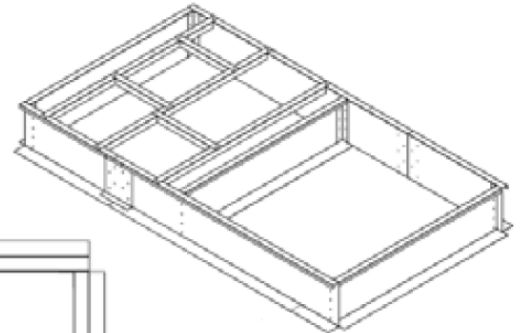
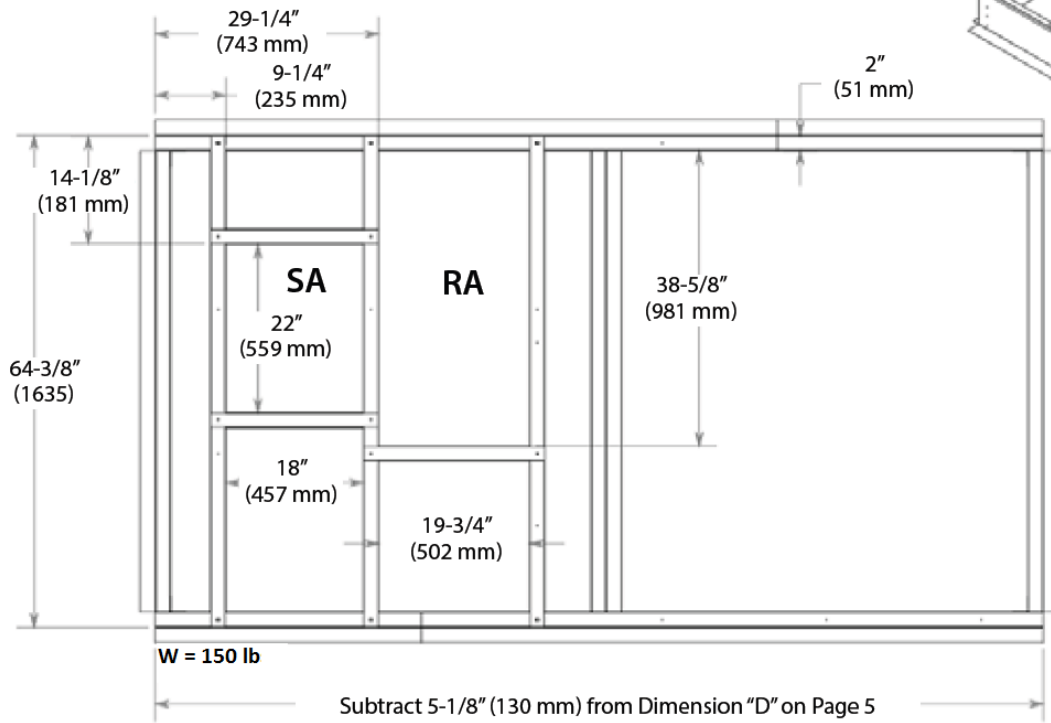

Note: The roof curb in the image does not necessarily represent the unit's configuration.

Unit Controls

- 24VAC, 20 VA power : Power supply 24VAC 20VA for external accessories
- Remote keypad and display : Gives the ability to monitor and set the unit remotely (with a wire connection).
- General Alarm dry contact : When the unit goes into alarm mode, a dry contact (NO) is closed.
- Start/Stop dry contact : The state of the unit (Start/stop) is controlled via a normally open (NO) dry contact.
- BACnet communication module - BACnet MS/TP : BACnet MS/TP connection port. The controller will communicate via a BACnet MS/TP link with the BMS.
- Low airflow switch : Opening of a dry contact (NC) when no airflow is detected on supply blower
- Dirty filters contacts : Will close a dry contact when dirty filters are detected
- Terminal boards for exhaust air damper : Power and control (24VAC, 10VA) for the exhaust air damper (internal or external to the unit).
- Terminal boards for fresh air damper : Power and control (24VAC, 10VA) for the fresh air damper (internal or external to the unit).
- Occupancy control dry contact : The state of the unit (Start/stop) is controlled via a normally open (NO) dry contact.
- BacNet compatible controller : Unit is equipped with a BACnet compatible controller.
- Phase loss detection : Unit will stop when a phase loss occurs, automatic restart
- Wheel rotation detection : A dry contact is closed if no rotation is detected
- Fan interlock on OA : Dry contact (NO) that closes when the fresh air motor is started.
- End switch on dampers : Unit start conditionally to dampers opening

- Free Cooling dry contact : The Unit will go into free cooling mode when a dry contact (NO) is closed.
- Non-fused disconnect : The unit will be equipped with a Non-fused disconnect.

Components

- Hood on exhaust air : Hood covering the exhaust air discharge against weather element, protected with 3/8" bird screen.
- Hood on outside air intake : Hood covering the outside air intake against weather element, protected with 3/8" bird screen.
- MERV8 filters on EA : MERV8 filter rack in the exhaust air circuit.
- MERV8 filters on OA : MERV8 filter rack in the fresh air circuit.
- Prepainted exterior wall : Exterior wall galvanized steel is replaced with prepainted steel.
- Insulated Roof curb : of 14 in. high in 18 ga galvanized steel
- VFD on exhaust air motor : The exhaust air motor is controlled by a VFD installed inside the unit and powered by the unit. The 0-10VDC signal is by others.
- VFD on supply air motor : The fresh air motor is controlled by a VFD installed inside the unit and powered by the unit. The 0-10VDC signal is by others.
- Wheel speed variation (VFD) : The unit monitors the exhaust air temperature and modulate the wheel speed in order to maintain it above freezing. Note : Wheel performance does not include frost control and actual supply air temperature may be lower.
- Exhaust air motorized and insulated dampers : Motorized and insulated damper on exhaust air opening actuated with a two positions (spring return) actuator.
- Fresh air motorized and insulated dampers : Motorized and insulated damper on fresh air opening actuated with a two positions (spring return) actuator.
- Horizontal duct configuration
- (1) in S40 for Exhaust Air and frost management

Frost control

- Wheel speed variation (VFD) : The unit monitors the exhaust air temperature and modulate the wheel speed in order to maintain it above freezing. Note : Wheel performance does not include frost control and actual supply air temperature may be lower.

Custom Options

- Vented control panel to dissipate heat generated from VFDs
- Heated control panel to prevent frost

Wheel Performance

Model	Enthalpique Roue
Diameter	52 in
Spacing	0.17 hp

	Entering Fresh Air T1		Leaving Fresh Air T2	
	Summer	Winter	Summer	Winter
Net Air Flow (CFM)			4250	4250
Real Air Flow (CFM)	4606	4606	4381	4381
Temperature Dry Bulb (°F)	90	-4	79	53
Temperature Wet Bulb (°F)	73	-5	66	43
Relative humidity (%)	44.77	64.08	41.4	51.1
Enthalpy (BTU/lb)	36.5	-0.4	30.5	16.4
Capacity				

	Leaving Exhaust Air T4		Entering Exhaust Air T3	
	Summer	Winter	Summer	Winter
Air Flow (CFM)			4250	4250
Real Air Flow (CFM)	4606	4606	4381	4381
Temperature Dry Bulb (°F)	86	14	75	72
Temperature Wet Bulb (°F)	71	14	63	72
Relative humidity (%)	46.1	99.1	51.6	28.74
Enthalpy (BTU/lb)	34.4	4.9	28.4	22.5
Capacity				

Performance

	Summer	Winter
Fresh Air Pressure Drop (in H ₂ O)	0.91	0.91
Exhaust Air Pressure Drop (in H ₂ O)	0.9	0.9
Sensible Efficiency (%)	75.61	76.64
Latent Efficiency (%)	71.53	72.2
Total Efficiency (%)	73.45	75.57
Recovered energy (Tonnes)	9.4	
Recovered energy (MBH)		330.8
EATR	3	3
OACF	1.1	1.1

Fresh Air Blower Performance

Information

Air flow	4381 CFM	Shaft Diameter	1.1875 in
Total Static Pressure	2.29 in H ₂ O	Static Efficiency	42.69 %
Rotation Speed	1087 RPM	Elevation	0 ft
Power	3.7 HP	Temperature	70 °F

Sound data

	63	125	250	500	1000	2000	4000	8000	(Hz)	LwA: 86
Sound Power Level @ Frequency, re: 10 ⁻¹² Watts	84	89	85	81	80	80	76	71	(dB)	Sones:25

Exhaust Air Blower Performance

Information

Air flow	4606 CFM	Shaft Diameter	1.1875 in
Total Static Pressure	2.26 in H ₂ O	Static Efficiency	39.59 %
Rotation Speed	1111 RPM	Elevation	0 ft
Power	4.14 HP	Temperature	70 °F

Sound data

	63	125	250	500	1000	2000	4000	8000	(Hz)	LwA: 88
Sound Power Level @ Frequency, re: 10 ⁻¹² Watts	87	91	88	83	82	81	79	74	(dB)	Sones:28

Coil specifications

Important notes

Terminal strip list CW5000e-AC26000200-5-1 rev. 5

Name	Section	Description
Alimentation 24Vac pour accessoires / Power Supply 24VAC 20VA for accessories (1-2)	Client	24Vac power supply to power external accessories.
Contact de départ / Start contact (3-4)	Client	This contact initiates the machine's operation when closed. It operates in series with the Occupancy Control Contact and must be closed to enable startup.
Contact de Contrôle d'occupation / Occupancy control contact (5-6)	Client	This contact monitors occupancy and must also be closed, in series with the Start Contact, to authorize operation.
Contact alarme général / General alarm contact (11-12)	Client	This contact closes when an alarm is detected in the machine
Contact filtres sales frais / Supply dirty filters contact (15-16)	Client	Supply dirty filters contact
Contact filtres sales Vicié / Exhaust dirty filters contact (17-18)	Client	Exhaust dirty filters contact
Référence 10VDC / 10VDC reference (27A)	Client	10VDC reference
Contrôle 0-10V VFD du ventilateur frais (externe) / External supply blower VFD 0-10V control (27-28)	Client	External supply blower VFD 0-10V control
Contrôle 0-10V VFD du ventilateur Vicié (externe) /	Client	External exhaust blower VFD 0-10V control

Name	Section	Description
External exhaust blower VFD 0-10V control (29-30)		
Référence 10VDC / 10VDC reference (31A)	Client	10VDC reference
Contrôle 0-10V VFD de la roue thermique / External enthalpy wheel VFD 0-10V control (31-32)	Client	External enthalpy wheel VFD 0-10V control
Contact de refroidissement gratuit / Freecooling contact (33-34)	Client	Freecooling contact
Détecteur de basse limite de débit frais / Supply low limite air flow contact (63-64)	Client	Supply low limite air flow contact
Contact de confirmation de marche du ventilateur frais / Supply blower confirmation contact (71-72)	Client	Supply blower confirmation contact
S40 Sonde température évacuation/ Exhaust air sensor(113-114)	Internal	Exhaust air sensor
Détecteur de filtres sales air frais / Supply dirty filters detector (117-118)	Internal	Supply dirty filters detector
Détecteur de filtres sales air vicié / Exhaust dirty filters detector (119-120)	Internal	Exhaust dirty filters detector
Détecteur de débit Frais / Supply air flow detector (121-122)	Internal	Supply air flow detector
Actuateur du Volet Frais / Supply damper (147-148)	Internal	Supply damper
Interrupteur de fin de course volet frais / Supply damper limite switch (149-150)	Internal	Supply damper limite switch

Name	Section	Description
Actuateur du volet vicié / Exhaust damper (151-152)	Internal	Exhaust damper
Interrupteur de fin de course volet air vicié / Exhaust damper limite switch (153-154)	Internal	Exhaust damper limite switch
Actuateur du volet de contournement / Bypass damper (155-156)	Internal	Bypass damper
Sonde de détection de rotation de la roue thermique / Enthalpy wheel rotation sensor (163-164-165)	Internal	Enthalpy wheel rotation sensor
Ventilateur de panneau/ Panel fan (193-194)	Internal	Panel fan
Ventilateur frais / Supply blower (211-212-213)	Power	Supply blower
Ventilateur vicié / Exhaust blower (214-215-216)	Power	Exhaust blower
Roue thermique / Enthalpy wheel (217-218-219)	Power	Enthalpy wheel
Bacnet MSTP (N+ et N-) et une borne gnd (relier à NET+ et NET- sur contrôleur)	Communication	-

ECB-650 Pinout List CW5000e-AC26000200-5-1 rev.5

In/Out	Point Name	Description	Signal Type	Comments	Units	Part Number	Reverse Acting
UI1	WheelRotationDetector	WheelRotationDetector	Pulse	From Terminal 165	no-unit	-	-
UI2	PhaseLostDetector	Active when phase lost or phase invert	Digital	-	-	-	X
UI3	OverloadOverheat	MotorOverload or coil Overheat	Digital	Motor overload or coil Overheat	-	-	-
UI4	SupplyDamperEndSwitch	SupplyDamperEndSwitch	Digital	From Terminal 149 or 67	-	-	-
UI5	ExhaustDamperEndSwitch	ExhaustDamperEndSwitch	Digital	From Terminal 153 or 69	-	-	-
UI6	StartStop	StartStop	Digital	From Terminal 3	-	-	-
UI7	ForcedFreeCooling	ForcedFreeCooling	Digital	From Terminal 33	-	-	-

In/Out	Point Name	Description	Signal Type	Comments	Units	Part Number	Reverse Acting
UI8	ExternalSupplyVariableSpeedControl	ExternalSupplyVariableSpeedControl	0-10V	From Terminal 27	%	-	-
UI9	ExternalExhaustVariableSpeedControl	ExternalExhaustVariableSpeedControl	0-10V	From Terminal 29	%	-	-
UI10	ExternalWheelVariableSpeedControl	ExternalWheelVariableSpeedControl	0-10V	From Terminal 31	%	-	-
UI11	S11OutsideAirTempBeforeCore	S11 OutsideAirTempBeforeCore	10K Type II	From Terminal 103	°C	602053	-
UI12	S40ExhaustAirTemp	S40 ExhaustAirTemp	10K Type II	From Terminal 113	°C	602053	-
UI13	ControlPanelTemp	Control panel temperature sensor	10K Type II	Direct on controler input	°C	602053	-
UI14	SupplyAirDirtyFilter	SupplyAirDirtyFilter	Digital	From Terminal 117	-	-	-
UI15	ExhaustAirDirtyFilter	ExhaustAirDirtyFilter	Digital	From Terminal 119	-	-	-
UI16	SupplyAirFlow	Active when supply airflow detected	Digital	From Terminal 121	-	-	-

In/Out	Point Name	Description	Signal Type	Comments	Units	Part Number	Reverse Acting
UO1	SupplyBlowerOutput	SupplyBlowerOutput	Digital	Relay to Motor Start	-	-	-
UO2	SupplyDamperOutput	SupplyDamperOutput	Digital	Relay to Terminal 147 or 35	-	-	-
UO3	ExhaustDamperOutput	ExhaustDamperOutput	Digital	Relay to Terminal 151 or 39	-	-	-
UO4	ExhaustBlowerOutput	ExhaustBlowerOutput	Digital	Relay to Motor Start	-	-	-
UO5	AlarmRelayOutput	AlarmRelayOutput	Digital	Relay to Terminal 11-12	-	-	-
UO6	WheelRelayOutput	WheelRelayOutput	Digital	Relay to VFD Start	-	-	-
UO7	BypassOnOffDamperOutput	BypassOnOffDamperOutput	Digital	Relay to Terminal 155	-	-	-
UO8	ControlPanelFanOutput	ControlPanelFanOutput	Digital	Relay to Ctrl Panel Fan	-	-	-

In/Out	Point Name	Description	Signal Type	Comments	Units	Part Number	Reverse Acting
UO9	ControlPanelHeatOutput	ControlPanelHeatOutput	Digital	Relay to Ctrl Panel Heat	-	-	-
UO10	VFDWheelSpeedSignal	VFDWheelSpeedSignal	0-10V	To Wheel VFD	%	-	-
UO11	SupplyVariableSpeedSignal	SupplyVariableSpeedSignal	0-10V	To VFD or Terminal 169 or 175	%	-	-
UO12	ExhaustVariableSpeedSignal	ExhaustVariableSpeedSignal	0-10V	To VFD or Terminal 181 or 187	%	-	-

BACnet point list CW5000e-AC26000200-5-1 rev. 5

Object	Name	Description	Format	Default	Min	Max	Writable
Binary Input 0	WheelRotationDetector	WheelRotationDetector	Boolean (TRUE;FALSE)				Read Only
Binary Input 1	PhaseLostDetector	Active when phase lost or phase invert	Boolean (TRUE;FALSE)				Read Only
Binary Input 2	OverloadOverheat	MotorOverload or coil Overheat	Boolean (TRUE;FALSE)				Read Only
Binary Input 3	SupplyDamperEndSwitch	SupplyDamperEndSwitch	Boolean (TRUE;FALSE)				Read Only
Binary Input 4	ExhaustDamperEndSwitch	ExhaustDamperEndSwitch	Boolean (TRUE;FALSE)				Read Only
Binary Input 5	StartStop	StartStop	Boolean (TRUE;FALSE)				Read Only
Binary Input 6	ForcedFreeCooling	ForcedFreeCooling	Boolean (TRUE;FALSE)				Read Only
Analog Input 7	ExternalSupplyVariableSpeedControl	ExternalSupplyVariableSpeedControl	Unit: percent		0	100	Read Only
Analog Input 8	ExternalExhaustVariableSpeedControl	ExternalExhaustVariableSpeedControl	Unit: percent		0	100	Read Only
Analog Input 9	ExternalWheelVariableSpeedControl	ExternalWheelVariableSpeedControl	Unit: percent		0	100	Read Only
Analog Input 10	S11OutsideAirTempBeforeCore	S11 OutsideAirTempBeforeCore	Unit: degrees Celcius,Unit:				Read-only

Object	Name	Description	Format	Default	Min	Max	Writable
			degrees Fahrenheit				
Analog Input 11	S40ExhaustAirTemp	S40 ExhaustAirTemp	Unit: degrees Celcius,Unit: degrees Fahrenheit				Read-only
Analog Input 12	ControlPanelTemp	Control panel temperature sensor	Unit: degrees Celcius,Unit: degrees Fahrenheit				Read-only
Binary Input 13	SupplyAirDirtyFilter	Supply Air Dirty Filter	Boolean (TRUE;FALSE)	0			Read-only
Binary Input 14	ExhaustAirDirtyFilter	ExhaustAirDirtyFilter	Boolean (TRUE;FALSE)				Read-only
Binary Input 15	SupplyAirFlow	Supply Air Flow	Boolean (TRUE;FALSE)				Read-only
Binary Output 0	SupplyBlowerOutput	SupplyBlowerOutput	Boolean (TRUE;FALSE)				Writable
Binary Output 1	SupplyDamperOutput	SupplyDamperOutput	Boolean (TRUE;FALSE)				Writable
Binary Output 2	ExhaustDamperOutput	ExhaustDamperOutput	Boolean (TRUE;FALSE)				Writable

Object	Name	Description	Format	Default	Min	Max	Writable
Binary Output 3	ExhaustBlowerOutput	ExhaustBlowerOutput	Boolean (TRUE;FALSE)				Writable
Binary Output 4	AlarmRelayOutput	AlarmRelayOutput	Boolean (TRUE;FALSE)				Writable
Binary Output 5	WheelRelayOutput	WheelRelayOutput	Boolean (TRUE;FALSE)				Writable
Binary Output 6	BypassOnOffDamperOutput	BypassOnOffDamperOutput	Boolean (TRUE;FALSE)				Writable
Binary Output 7	ControlPanelFanOutput	ControlPanelFanOutput	Boolean (TRUE;FALSE)				Writable
Binary Output 8	ControlPanelHeatOutput	ControlPanelHeatOutput	Boolean (TRUE;FALSE)				Writable
Analog Output 9	VFDWheelSpeedSignal	VFDWheelSpeedSignal	Unit: percent		0	100	Writable
Analog Output 10	SupplyVariableSpeedSignal	SupplyVariableSpeedSignal	Unit: percent		0	100	Writable
Analog Output 11	ExhaustVariableSpeedSignal	ExhaustVariableSpeedSignal	Unit: percent		0	100	Writable

Object	Name	Description	Format	Default	Min	Max	Writable
Analog Value 67	DelayBeforeMotorFault	Only use on Aldes recommendation	Unit: seconds	0	0		Writable
Analog Value 42	ExhaustMotorStartDelay	Delay before Exhaust motor start after exhaust damper open	Unit: seconds	30			Writable
Binary Value 3	ExhaustStartBacnet	Start Exhaust air, need a close contact on terminal 9-10	Boolean (TRUE;FALSE)	1	0	1	Writable
Multi State Value 1	FaultCode	Fault code when fault happen	Enum: Fault	1			Writable
Binary Value 1	GeneralStartBacnet	Start unit by Bacnet, need a close contact on terminal 3-4 and 5-6	Boolean (TRUE;FALSE)	1			Writable
Binary Value 24	ResetAlarm	Resets the alarm if no longer valid	Boolean (TRUE;FALSE)	0			Writable
Analog Value 41	SupplyMotorStartDelay	Delay before supply motor start after damper open	Unit: seconds	35			Writable
Binary Value 2	SupplyStartBacnet	Start supply air , need a close contact on terminal 7-8	Boolean (TRUE;FALSE)	1			Writable

Object	Name	Description	Format	Default	Min	Max	Writable
Analog Value 02	FreeCoolingStateTimer	Time Remaining in FreeCooling State	Unit: minutes				Writable
Analog Value 57	FreeCoolingWheelOFFTime	Wheel freecooling pulse off time	Unit: minutes	120			Writable
Analog Value 56	FreeCoolingWheelOnTime	Wheel freecooling pulse on time	Unit: minutes	2			Writable
Analog Value 62	WheelInactiveTimeLimit	WheelInactiveTimeLimit	Unit: seconds	30			Writable
Binary Value 25	WheelRotationDetectionActive	Wheel Rotation detection active	Boolean (TRUE;FALSE)	1			Writable
Analog Value 03	WheelSensorPulseCount	WheelSensorPulseCount					Writable
Binary Value 6	BacnetForcedFreeCooling	BacnetForcedFreeCooling	Boolean (TRUE;FALSE)				Writable
Analog Value 45	DefrostIntegralTime	Defrost Integral Time		1000			Writable
Analog Value 44	DefrostProportionnalBand	Defrost Proportionnal band		12			Writable

Object	Name	Description	Format	Default	Min	Max	Writable
Analog Value 43	DefrostSetPoint	Defrost SetPoint	Unit: degrees Celcius,Unit: degrees Fahrenheit				Writable
Binary Value 26	PreHeatInvertSignal	Inverts PreHeat Signal (When active : 10V=No heat)	Boolean (TRUE;FALSE)	0			Writable
Analog Value 06	BacnetExhaustSpeedControl	BacnetExhaustSpeedControl	Unit: percent		0	100	Writable
Analog Value 05	BacnetSupplySpeedControl	BacnetSupplySpeedControl	Unit: percent		0	100	Writable
Multi State Value 21	VariableSpeedControlSource	select the blowers speed control 1=external analog ; 2=Bacnet	Enum: SpeedControl	1			Writable
Analog Value 08	BacnetWheelSpeedControl	BacnetWheelSpeedControl	Unit: percent		0	100	Writable
Multi State Value 22	VariableWheelSpeedControlSource	select the Wheel speed control 1=external analog 2=Bacnet	Enum: SpeedControl				Writable
Analog Value 68	CoolingPanelSetPoint	CoolingPanelSetPoint	Unit: degrees Celcius,Unit: degrees Fahrenheit				Writable

Object	Name	Description	Format	Default	Min	Max	Writable
Analog Value 69	HeatingPanelSetPoint	HeatingPanelSetPoint	Unit: degrees Celcius	0			Writable



HTS Oshawa

2001 Thickson Rd, South
Unit #11
Whitby, ON L1N 6J3
T 905.579.6700
F 905.597.5290

ontario.htseng.com

SUBMITTAL DATA
APPROVAL REQUIRED

IOM LINK

https://htseng-my.sharepoint.com/:f:/g/personal/curtis_metrow_hts_com/IgD_JwPmhDmwQZINhdRqf-csAWEu08nbwsg2MnbpeWdmLds?e=AVpGVC

Submittal # 98496

APPROVAL REQUIRED

Project 22600705-OWN-1- DCDSB - Archbishop Denis O'Connor
Leader Curtis Metrow
Job Site 80 Mandrake St, Ajax, ON, Canada
Submission Date 2026-04-07
Sold To DURHAM CDSB *
Submitted By Curtis Metrow

Contacts

Role	Customer	Our Rep
Owner	Durham Catholic District School Board *	Curtis Metrow
Designer	Ellard Willson Engineering	Steve Cukrovani

Deliverables

Track #	335957		
Tag	RTU-7,8		
Description	Rebel Rooftop Systems		
Quantity	2		
Manufacturer	Daikin Applied		
Specification			
Production Lead Time	16 - 18 Weeks		
Revision #	1		

Attention:

- 1) HTS will provide equipment in accordance with the attached shop drawings.
- 2) Upon approved submittal and customer release, HTS will release equipment to fabrication per the published lead times. Any storage fees associated with project schedule changes will be the responsibility of the purchaser.
- 3) HTS can provide freight and logistics to the purchaser as an added benefit of doing business with HTS. When freight is received by the purchaser, any noticeable damage must be recorded. Otherwise, HTS is not responsible for subsequent damage claims.

Approval Stamps

<p>RYBKA ELLARD WILLSON INC</p> <p><input type="checkbox"/> REVIEWED</p> <p><input checked="" type="checkbox"/> REVIEWED AS NOTED</p> <p><input type="checkbox"/> REVISE AND RESUBMIT</p> <hr/> <p>SUBMITTAL WAS REVIEWED FOR DESIGN CONFORMITY AND GENERAL CONFORMANCE TO CONTRACT DOCUMENTS ONLY. THE CONTRACTOR IS RESPONSIBLE FOR CONFIRMING AND CORRELATING DIMENSIONS AT JOB SITES FOR TOLERANCES, CLEARANCES, QUANTITIES, FABRICATION PROCESSES AND TECHNIQUES OF CONSTRUCTION, COORDINATION OF THEIR WORK WITH OTHER TRADES AND FULL COMPLIANCE WITH THE CONTRACT DOCUMENTS.</p> <hr/> <p>BY JMACQUARRIE DATE 2026/4/7</p>		<p>RYBKA ELLARD WILLSON INC</p> <p><input type="checkbox"/> REVIEWED</p> <p><input checked="" type="checkbox"/> REVIEWED AS NOTED</p> <p><input type="checkbox"/> REVISE AND RESUBMIT</p> <hr/> <p>SUBMITTAL WAS REVIEWED FOR DESIGN CONFORMITY AND GENERAL CONFORMANCE TO CONTRACT DOCUMENTS ONLY. THE CONTRACTOR IS RESPONSIBLE FOR CONFIRMING AND CORRELATING DIMENSIONS AT JOB SITES FOR TOLERANCES, CLEARANCES, QUANTITIES, FABRICATION PROCESSES AND TECHNIQUES OF CONSTRUCTION, COORDINATION OF THEIR WORK WITH OTHER TRADES AND FULL COMPLIANCE WITH THE CONTRACT DOCUMENTS.</p> <hr/> <p>BY FCHANG DATE 4/8/2026</p>	
--	---	---	---

REW JM COMMENTS:

- PROVIDE UNITS WITH 600V POWER
- RE-ISSUE DRAWINGS TO RYBKA SHOWING REVISED POWER FOR OUR COORDINATION PURPOSES.
- CONNECT TO BAS BACNET MSTP
- RTU-7 TO BE INTERLOCKED WITH EXHAUST FANS. WHEN FANS ARE OPERATING, UNIT OPERATES UNDER 100% MUA MODE, WHEN FANS ARE OFF UNIT RETURNS TO MIN VENTILATION.
- RTU-8 IS SERVING A WOOD SHOP AND WILL BE 100% MUA



HTS Oshawa

2001 Thickson Rd, South
Unit #11
Whitby, ON L1N 6J3
T 905.579.6700
F 905.597.5290

ontario.htseng.com

SUBMITTAL DATA
APPROVAL REQUIRED

SEMI CUSTOM ROOFTOP UNITS

RTU-7, 8

Technical Information And Drawings

Notes:

- 1) Electrical:208V/3ph
 - a. RTU-7 FLA / MCA / MOP: 11.1A / 13.5.A / 20A
 - b. RTU-8 FLA / MCA / MOP: 11.1A / 13.5A / 20A
- 2) Unit Options:
 - a. Air handling unit with gas heater, 10:1 modulating turndown
 - b. Filter rack – 2" MERV 13 filters
 - c. Supply fans c/w ECM motors
 - d. Barometric relief exhaust damper
 - e. Bottom supply & return duct connections
 - f. Adaptor roof curb
- 3) Controls
 - a. Microtech DDC controller
 - b. BACnet MSTP communication module
 - c. Zone temperature control – zone temperature with setpoint override ships loose for field wiring to unit. Alternatively, unit can control to discharge air temperature setpoint reset via BACnet.
- 4) Assembly Info:
 - i. Units ship complete
- 5) Warranty
 - a. 2-year factory parts warranty included

Job Information	Technical Data Sheet
-----------------	----------------------

Job Name	22600705 - DCDSB Archbishop Dennis Oconnor
Date	4/7/2026
Submitted By	Terry Loyala
Software Version	14.10
Unit Tag	RTU-7



Unit Overview			
---------------	--	--	--

Model Number	Cabinet	Voltage V/Hz/Phase	Design Cooling Capacity Btu/hr
DAHA07A	B	208/60/3	45661

Unit	
------	--

Model Number:	DAHA07A
Model Type:	Air Handler
Heat Type:	Gas
Energy Recovery:	None
Application:	Variable Air Volume, Single Zone (Mixed Air or 100% OA)
Controls:	Microtech
Outside Air:	0-100% Economizer with Drybulb Control
Altitude:	0 ft
Approval	cETLus

Physical			
----------	--	--	--

Dimensions and Weight			
Length	Height	Width	Weight
91.0 in	56.8 in	57.9 in	1454 lb
Corner Weights			
L1	L2	L3	L4
268 lb	224 lb	439 lb	523 lb
Construction			
Exterior	Insulation and Liners	Air Opening Location	
		Return	Supply
Painted Galvanized Steel	1" Injected Foam, R-7, Galvanized Steel Liner	Bottom	Bottom

Electrical			
------------	--	--	--

Unit FLA	MCA	MROPD	SCCR
11.1 A	13.5 A	20 A	5 kAIC
Note:	Use only copper supply wires with ampacity based on 75° C conductor rating. Connections to terminals must be made with copper lugs and copper wire.		

Return/Outside/Exhaust Air		
----------------------------	--	--

Outside Air Option		
Type	Damper Pressure Drop	Exhaust Air Type
0-100% Econ with Dry Bulb Control	0.07 inH ₂ O	Barometric Relief

Filter Section

Physical				
Type	Quantity / Size	Face Area	Face Velocity	Air Pressure Drop
2" ONLY RACK - with MERV13 factory filters. Is NOT a combo rack.	6 / 18 in x 24 in x 2 in	18.0 ft ²	166.7 ft/min	0.08

Fan Section

Fan					
Type	Fan Wheel Diameter	Fan Series	Fan Isolation	Total Input Power (kW)	Fan Energy Index (FEI)
SWSI AF	14 in	Series II	None	0.68664	1.470
Performance					
Airflow	Total Static Pressure	Fan Speed	Brake Horsepower	Altitude	
3000 CFM	0.8 inH ₂ O	2204 rpm	0.81 HP	0 ft	
Motor				Drive	
Type	Horsepower	Efficiency	FLA	Type	
ECM Motor	4.0	Premium	9.7 A	Direct Drive	

Gas Heat Section

Physical						
Airflow	Max Allowable Burner Temp Rise	Size	Connection (Qty) Size	Heat Exchanger Material		
3000 CFM	100.0 °F	300 MBH	(1) 0.75 in. Female NPT	Stainless Steel		
Performance						
Capacity Btu/hr	Air Temperature Dry Bulb		Air Pressure Drop inH ₂ O	Gas Pressure		Modulation
	Entering °F	Leaving °F		Minimum inH ₂ O	Maximum inH ₂ O	
243000	-4.0	70.7	0.14	5	14	Modulating 10:1 Turndown

Notes: Refer to fan curve for applicability of approximate airflows

Internal Pressure Drop Calculation

External Static Pressure:	0.50 inH ₂ O
Filter:	0.08 inH ₂ O
Outside Air:	0.07 inH ₂ O
Chilled Water Coil:	0.00 inH ₂ O
Gas Heat:	0.14 inH ₂ O
Total Static Pressure:	0.80 inH ₂ O

Sound

Frequency	Sound Power (db)							
	63 Hz	125 Hz	250 Hz	500 Hz	1 kHz	2 kHz	4 kHz	8 kHz
Inlet	75	74	82	77	79	78	73	68
Discharge	75	77	85	82	85	84	81	76

Options

Electrical	
Field Connection:	Non-Fused Disconnect Switch
Powered Receptacle:	Field powered 115V GFI outlet
Controls	
Communication Card:	BACnet/MSTP card, Factory installed

Factory Installed Sensors

Leaving Coil/Entering Fan Temperature Sensor
Duct High Limit Switch
BACnet/MSTP Card
Return Air Temperature Sensor
Discharge Air Temperature sensor – Wired in unit, mounted in supply duct
Outside Air Temperature Sensor
Dirty Filter On/Off Switch
Supply Fan Air Proving Via Modbus

Warranty

Parts	Standard One Year
Gas Heat Exchanger	Standard one Year

Notes

Forklift slots to remove unit from a truck bed. The fork lift slots are not to be used to place unit on a roof curb. Unit is to be lifted onto curb per IOM instructions.

Accessories

Mandatory	
Part Number	Description
910143408	DDC Space Sensor with Setpoint Adj and Tenant Over

2 YEARS

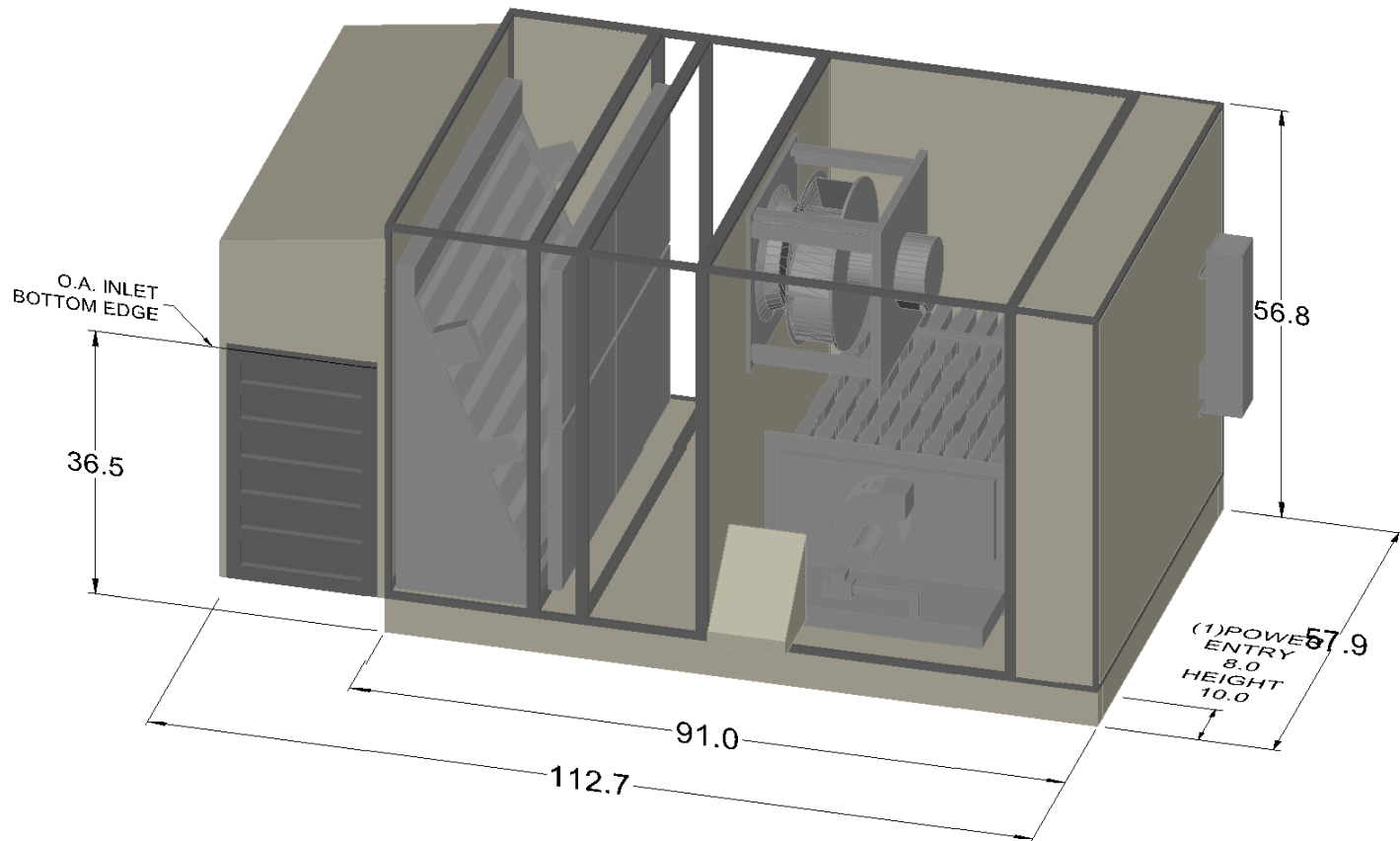

Notes:

- (1) Recommended location for optional field cut side power connection.
- (2) Horizontal gas connection only. Gas pipe routing within the roofcurb is not available.

	Unit Tag: RTU-7			Sales Office: HTS Engineering Ltd.			 13600 Industrial Park Blvd. Minneapolis, MN 55441 www.DaikinApplied.com Software Version: 14.10
Product: Rebel	Project Name: 22600705 - DCDSB Archbishop			Sales Engineer:			
Model: DAHA07A	Apr. 07, 2026	Ver/Rev:	Sheet: 1 of 1	Scale: NTS	Tolerance: +/- 0.25"	Dwg Units: in [mm]	

No change to this drawing may be made unless approved in writing by Daikin Applied. Purchaser must determine that the equipment is fit and sufficient for the job specifications.

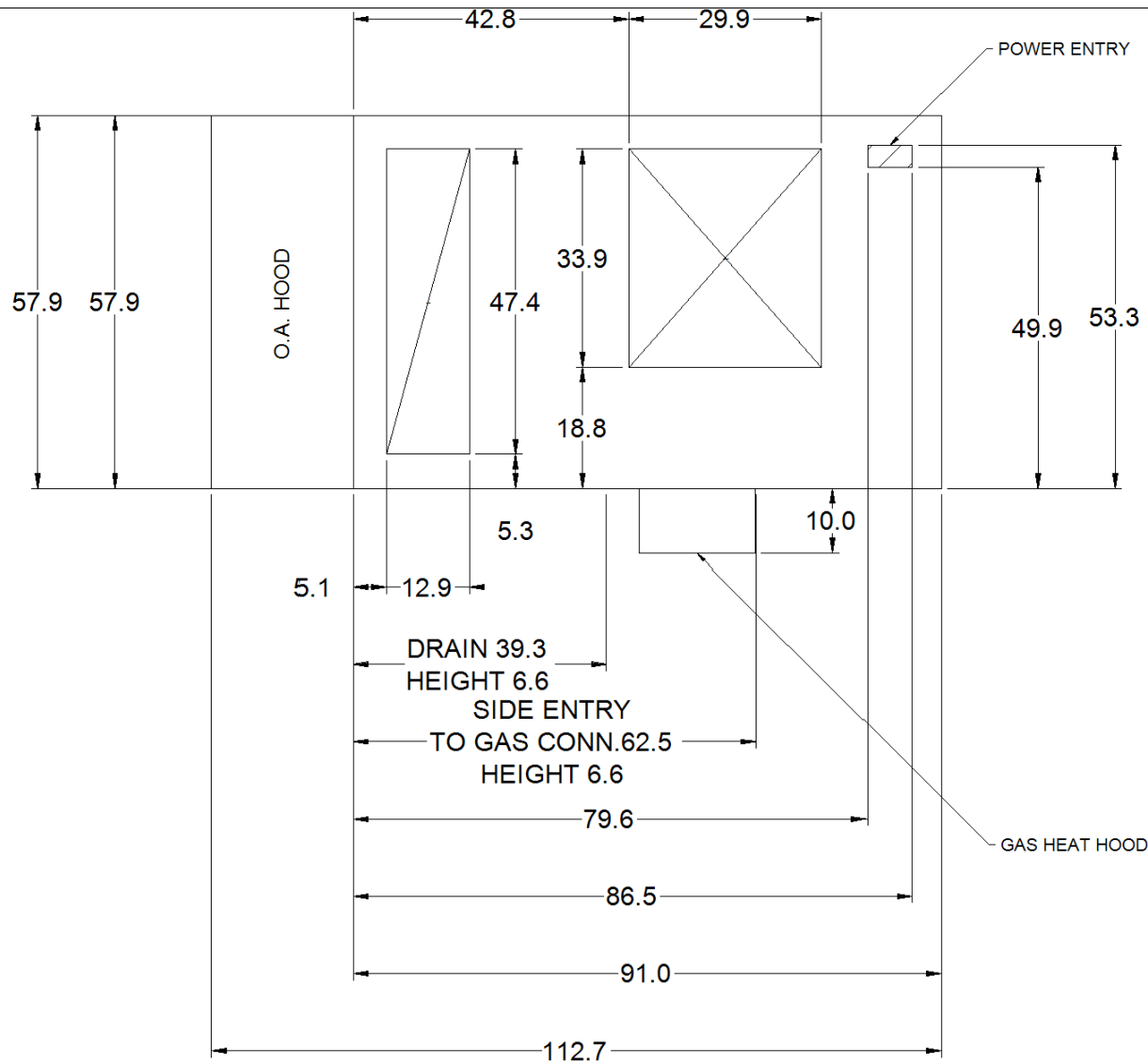

PLAN VIEW - OPENINGS & OVERALL

Unit Tag: RTU-7		Sales Office: HTS Engineering Ltd.		 13600 Industrial Park Blvd. Minneapolis, MN 55441 www.DaikinApplied.com Software Version: 14.10		
Product: Rebel		Sales Engineer:				
Model: DAHA07A	Apr. 07, 2026	Ver/Rev:	Sheet: 1 of 1	Scale: NTS	Tolerance: +/- 0.25"	Dwg Units: in [mm]
No change to this drawing may be made unless approved in writing by Daikin Applied. Purchaser must determine that the equipment is fit and sufficient for the job specifications.						

Corner Weight L4 - 523 lb

Corner Weight L3 - 439 lb

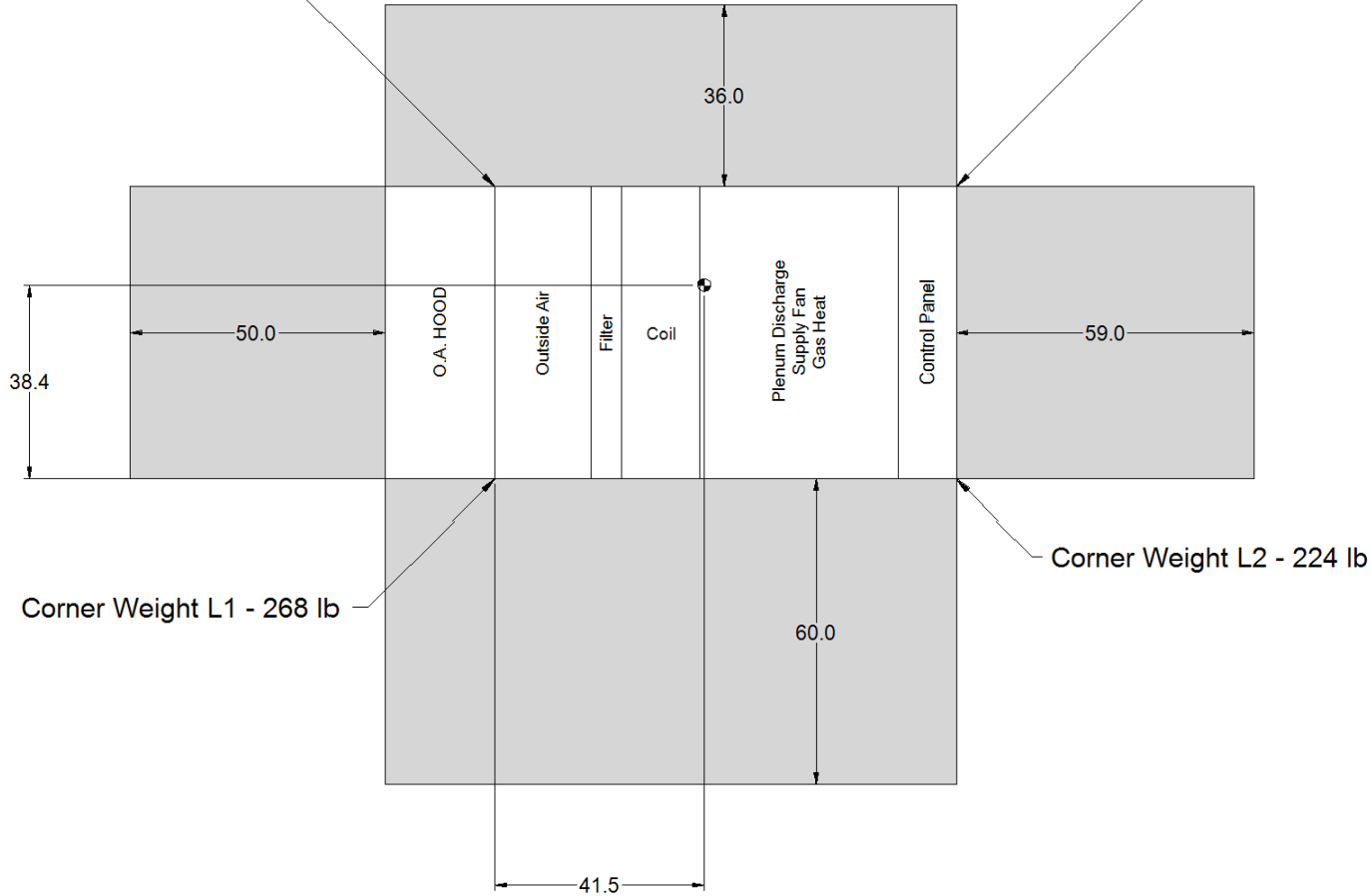

PLAN VIEW - CG, CORNER WEIGHTS, SERVICE CLEARANCE

Notes:

- (1) Center of Gravity Height = 27
- (2) Total Weight = 1454 lb

	Unit Tag: RTU-7		Sales Office: HTS Engineering Ltd.				 13600 Industrial Park Blvd. Minneapolis, MN 55441 www.DaikinApplied.com Software Version: 14.10
Product: Rebel	Project Name: 22600705 - DCDSB Archbishop		Sales Engineer:				
Model: DAHA07A	Apr. 07, 2026	Ver/Rev:	Sheet: 1 of 1	Scale: NTS	Tolerance: +/- 0.25"	Dwg Units: in [mm]	

No change to this drawing may be made unless approved in writing by Daikin Applied. Purchaser must determine that the equipment is fit and sufficient for the job specifications.

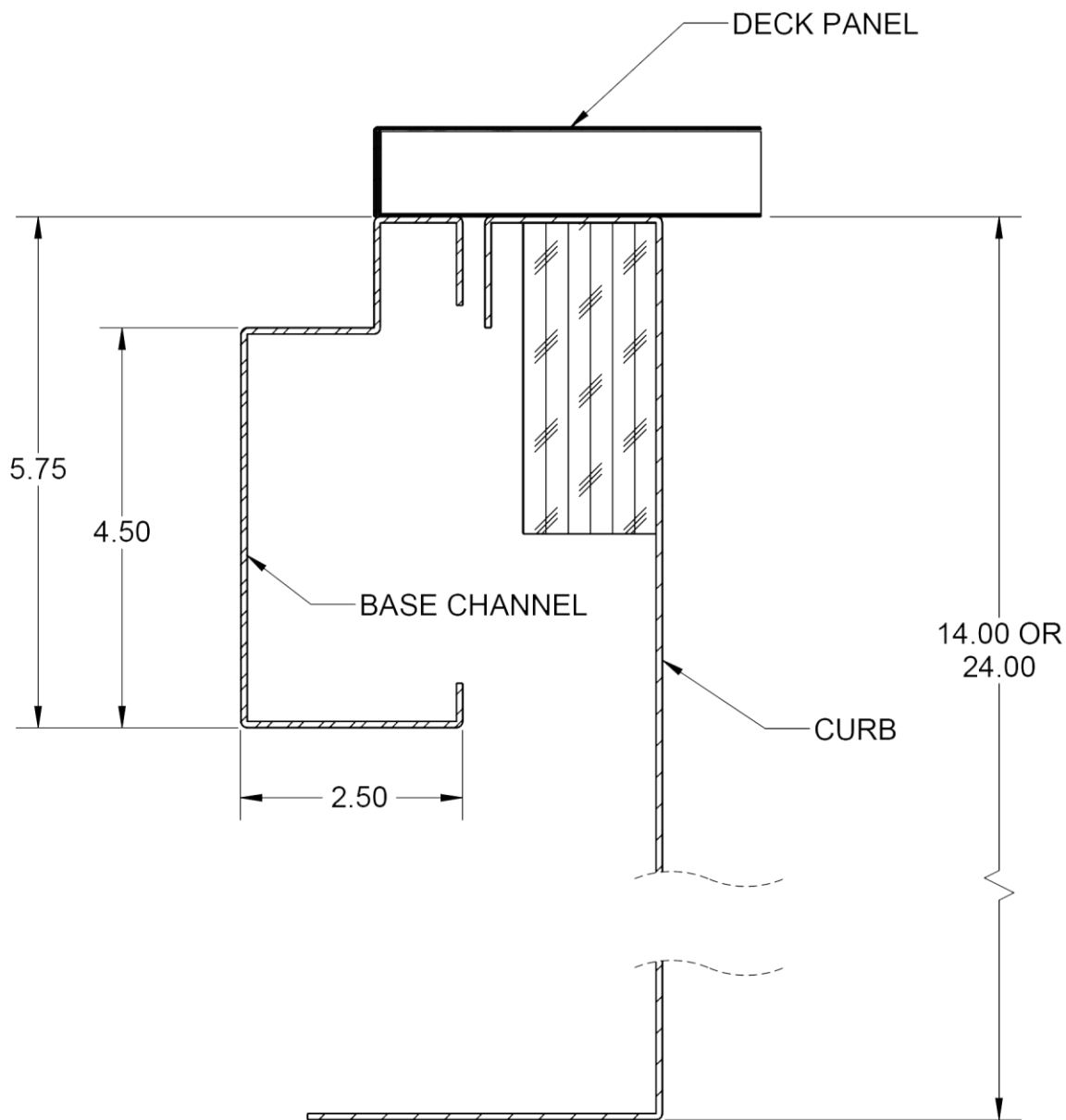

Curb Cross-Section View	Unit Tag: RTU-7			 13600 Industrial Park Blvd. Minneapolis, MN 55441 www.DaikinApplied.com Software Version: 14.10		
Product: Rebel	Project Name: 22600705 - DCDSB					
Model: DAHA07A	Sales Office: HTS Engineering Ltd.			Scale: NTS	Tolerance: +/-0.25"	Dwg Units: in [mm]
Sales Engineer:	Apr. 07, 2026	Ver/Rev:	Sheet 1 of 1			
No change to this drawing may be made unless approved in writing by Daikin Applied. Purchaser must determine that the equipment is fit and sufficient for the job specifications.						

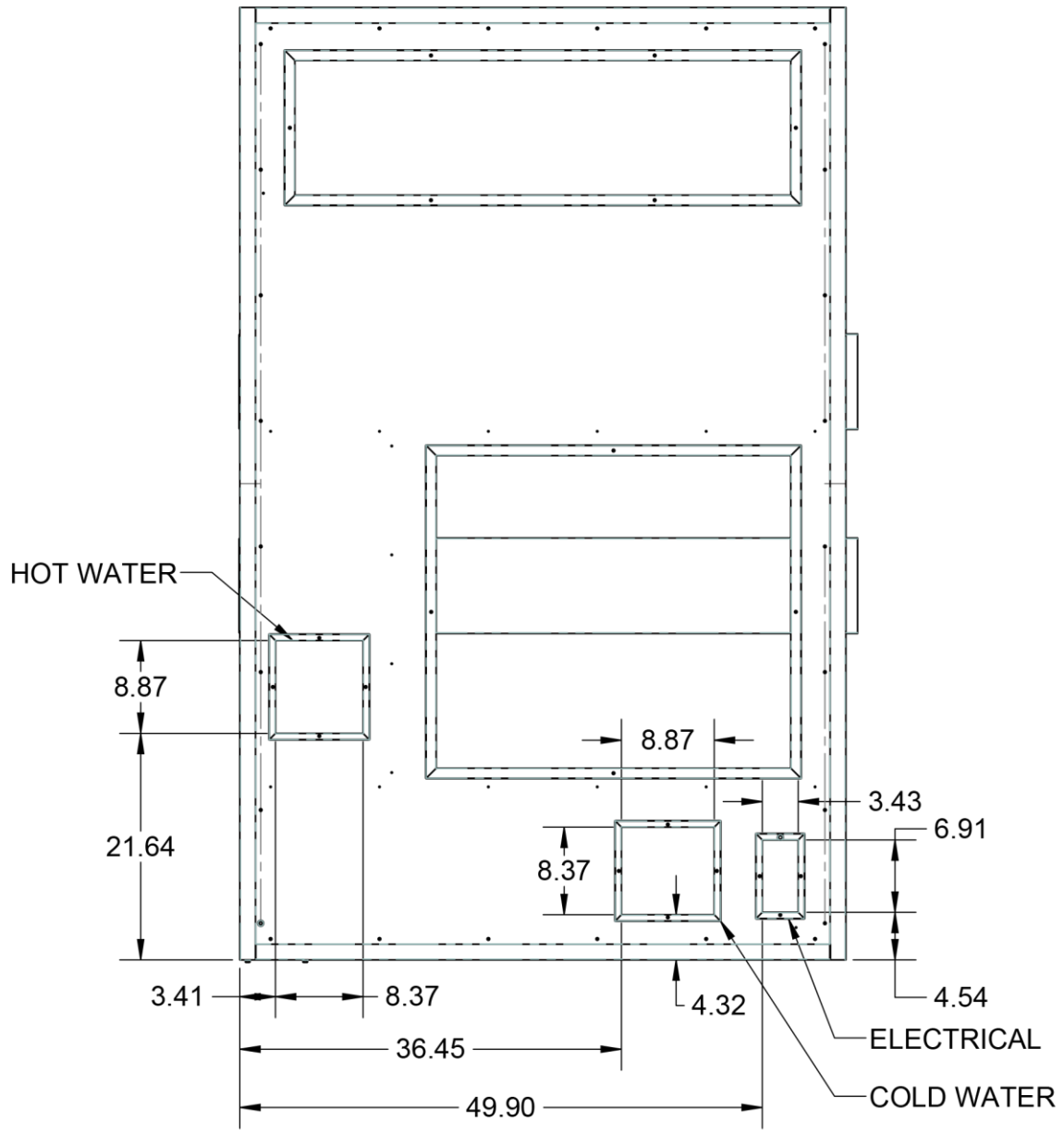

Plan View -Coil Piping Dimensions

Piping Entrance Locations View		Unit Tag: RTU-7		 13600 Industrial Park Blvd. Minneapolis, MN 55441 www.DaikinApplied.com Software Version: 14.10		
Product: Rebel		Project Name: 22600705 - DCDSB				
Model: DAHA07A		Sales Office: HTS Engineering Ltd.		Scale: NTS Tolerance: +/-0.25" Dwg Units: in [mm]		
Sales Engineer:		Apr. 07, 2026	Ver/Rev:	Sheet 1 of 1		
No change to this drawing may be made unless approved in writing by Daikin Applied. Purchaser must determine that the equipment is fit and sufficient for the job specifications.						

Job Information	Technical Data Sheet
-----------------	----------------------

Job Name	22600705 - DCDSB Archbishop Dennis Oconnor
Date	4/7/2026
Submitted By	Terry Loyala
Software Version	14.10
Unit Tag	RTU-8



Unit Overview			
---------------	--	--	--

Model Number	Cabinet	Voltage V/Hz/Phase	Design Cooling Capacity Btu/hr
DAHA07A	B	208/60/3	45661

Unit	
------	--

Model Number:	DAHA07A
Model Type:	Air Handler
Heat Type:	Gas
Energy Recovery:	None
Application:	Variable Air Volume, Single Zone (Mixed Air or 100% OA)
Controls:	Microtech
Outside Air:	0-100% Economizer with Comparative Enthalpy Control
Altitude:	0 ft
Approval	cETLus

Physical			
----------	--	--	--

Dimensions and Weight			
Length	Height	Width	Weight
91.0 in	56.8 in	57.9 in	1454 lb
Corner Weights			
L1	L2	L3	L4
268 lb	224 lb	439 lb	523 lb
Construction			
Exterior	Insulation and Liners	Air Opening Location	
		Return	Supply
Painted Galvanized Steel	1" Injected Foam, R-7, Galvanized Steel Liner	Bottom	Bottom

Electrical			
------------	--	--	--

Unit FLA	MCA	MROPD	SCCR
11.1 A	13.5 A	20 A	5 kAIC
Note:	Use only copper supply wires with ampacity based on 75° C conductor rating. Connections to terminals must be made with copper lugs and copper wire.		

Return/Outside/Exhaust Air		
----------------------------	--	--

Outside Air Option		
Type	Damper Pressure Drop	Exhaust Air Type
0-100% Econ with Comparative Enthalpy Control	0.07 inH ₂ O	Barometric Relief

Filter Section

Physical				
Type	Quantity / Size	Face Area	Face Velocity	Air Pressure Drop
2" ONLY RACK - with MERV13 factory filters. Is NOT a combo rack.	6 / 18 in x 24 in x 2 in	18.0 ft ²	166.7 ft/min	0.08

Fan Section

Fan					
Type	Fan Wheel Diameter	Fan Series	Fan Isolation	Total Input Power (kW)	Fan Energy Index (FEI)
SWSI AF	14 in	Series II	None	0.68664	1.470
Performance					
Airflow	Total Static Pressure	Fan Speed	Brake Horsepower	Altitude	
3000 CFM	0.8 inH ₂ O	2204 rpm	0.81 HP	0 ft	
Motor				Drive	
Type	Horsepower	Efficiency	FLA	Type	
ECM Motor	4.0	Premium	9.7 A	Direct Drive	

Gas Heat Section

Physical						
Airflow	Max Allowable Burner Temp Rise	Size	Connection (Qty) Size	Heat Exchanger Material		
3000 CFM	100.0 °F	300 MBH	(1) 0.75 in. Female NPT	Stainless Steel		
Performance						
Capacity Btu/hr	Air Temperature Dry Bulb		Air Pressure Drop inH ₂ O	Gas Pressure		Modulation
	Entering °F	Leaving °F		Minimum inH ₂ O	Maximum inH ₂ O	
243000	-4.0	70.7	0.14	5	14	Modulating 10:1 Turndown

Notes: Refer to fan curve for applicability of approximate airflows

Internal Pressure Drop Calculation

External Static Pressure:	0.50 inH ₂ O
Filter:	0.08 inH ₂ O
Outside Air:	0.07 inH ₂ O
Chilled Water Coil:	0.00 inH ₂ O
Gas Heat:	0.14 inH ₂ O
Total Static Pressure:	0.80 inH ₂ O

Sound

Frequency	Sound Power (db)							
	63 Hz	125 Hz	250 Hz	500 Hz	1 kHz	2 kHz	4 kHz	8 kHz
Inlet	75	74	82	77	79	78	73	68
Discharge	75	77	85	82	85	84	81	76

Options

Electrical	
Field Connection:	Non-Fused Disconnect Switch
Powered Receptacle:	Field powered 115V GFI outlet
Controls	
Communication Card:	BACnet/MSTP card, Factory installed

Factory Installed Sensors

Leaving Coil/Entering Fan Temperature Sensor
Duct High Limit Switch
BACnet/MSTP Card
Return Air Temperature Sensor
Discharge Air Temperature sensor – Wired in unit, mounted in supply duct
Outside Air Temperature Sensor
Return Air Enthalpy Sensor
Outside Air Enthalpy Sensor
Dirty Filter On/Off Switch
Supply Fan Air Proving Via Modbus

Warranty

Parts	Standard One Year
Gas Heat Exchanger	Standard one Year

Notes

Forklift slots to remove unit from a truck bed. The fork lift slots are not to be used to place unit on a roof curb. Unit is to be lifted onto curb per IOM instructions.

Accessories

		Mandatory
Part Number		Description
910143408		DDC Space Sensor with Setpoint Adj and Tenant Over

2 YEARS

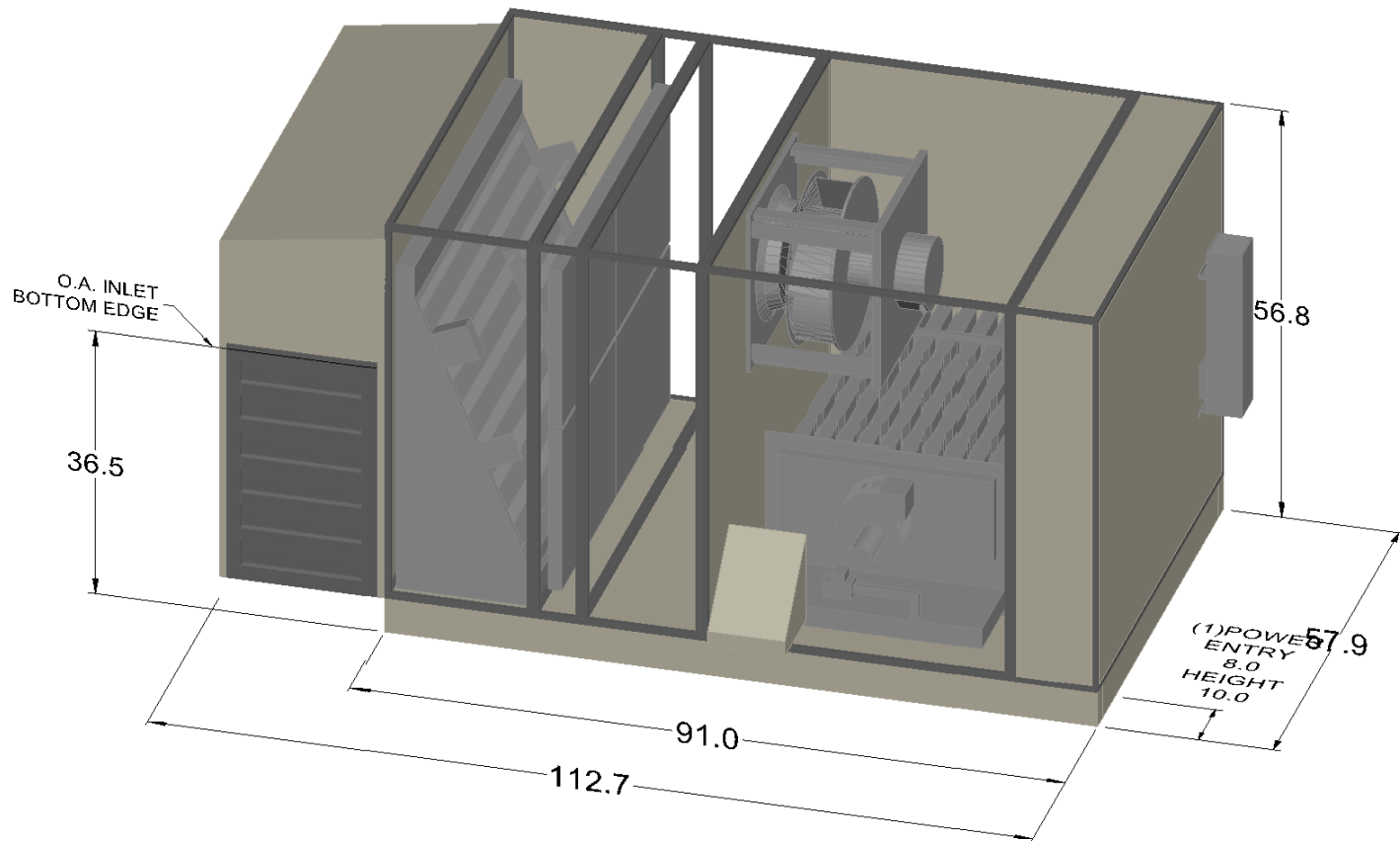

Notes:

- (1) Recommended location for optional field cut side power connection.
- (2) Horizontal gas connection only. Gas pipe routing within the roof curb is not available.

	Unit Tag: RTU-8			Sales Office: HTS Engineering Ltd.			 13600 Industrial Park Blvd. Minneapolis, MN 55441 www.DaikinApplied.com Software Version: 14.10
Product: Rebel	Project Name: 22600705 - DCDSB Archbishop			Sales Engineer:			
Model: DAHA07A	Apr. 07, 2026	Ver/Rev:	Sheet: 1 of 1	Scale: NTS	Tolerance: +/- 0.25"	Dwg Units: in [mm]	
No change to this drawing may be made unless approved in writing by Daikin Applied. Purchaser must determine that the equipment is fit and sufficient for the job specifications.							

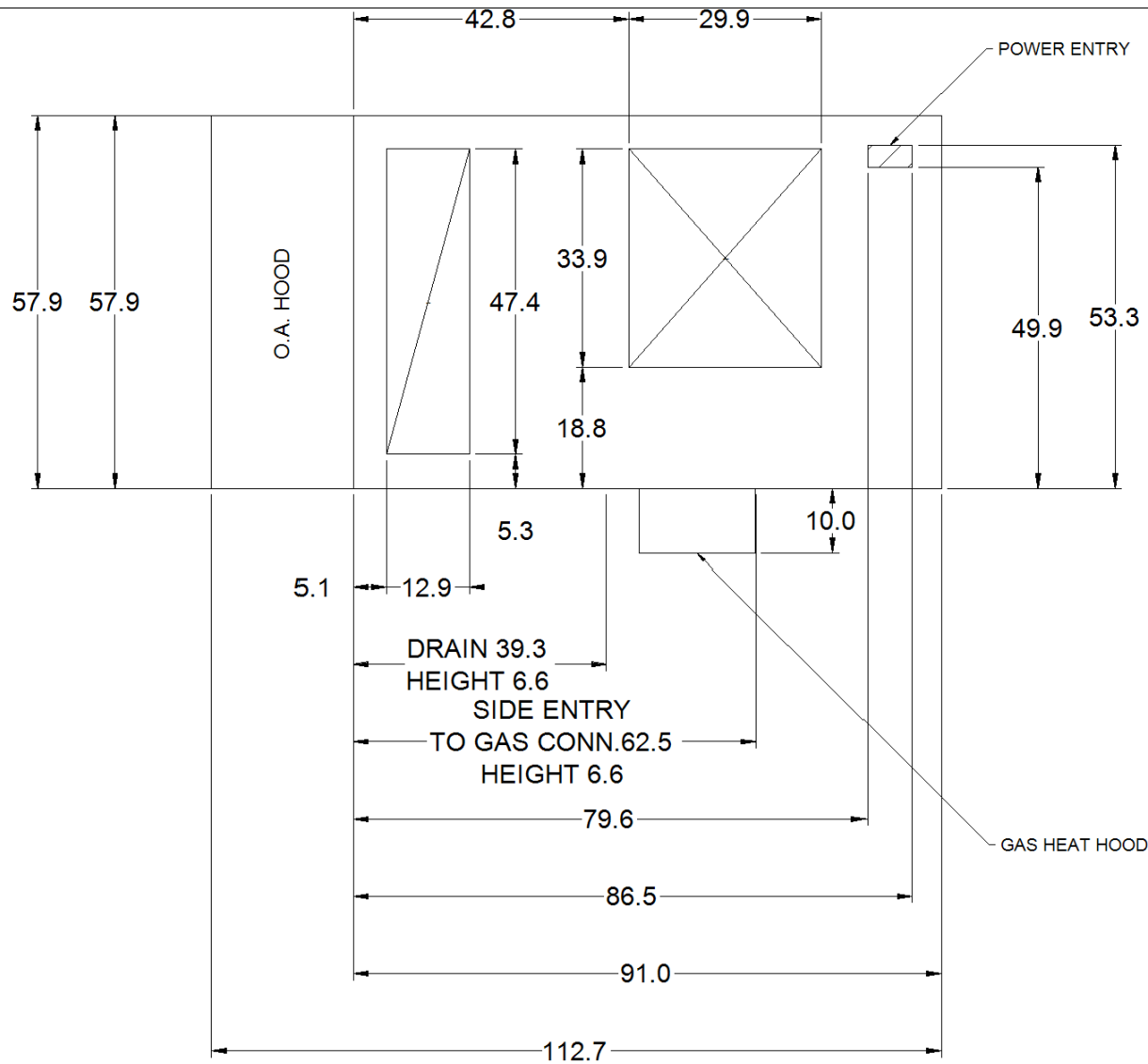

PLAN VIEW - OPENINGS & OVERALL

Unit Tag: RTU-8		Sales Office: HTS Engineering Ltd.		 13600 Industrial Park Blvd. Minneapolis, MN 55441 www.DaikinApplied.com Software Version: 14.10		
Product: Rebel		Sales Engineer:				
Model: DAHA07A	Apr. 07, 2026	Ver/Rev:	Sheet: 1 of 1	Scale: NTS	Tolerance: +/- 0.25"	Dwg Units: in [mm]

No change to this drawing may be made unless approved in writing by Daikin Applied. Purchaser must determine that the equipment is fit and sufficient for the job specifications.

Corner Weight L4 - 523 lb

Corner Weight L3 - 439 lb

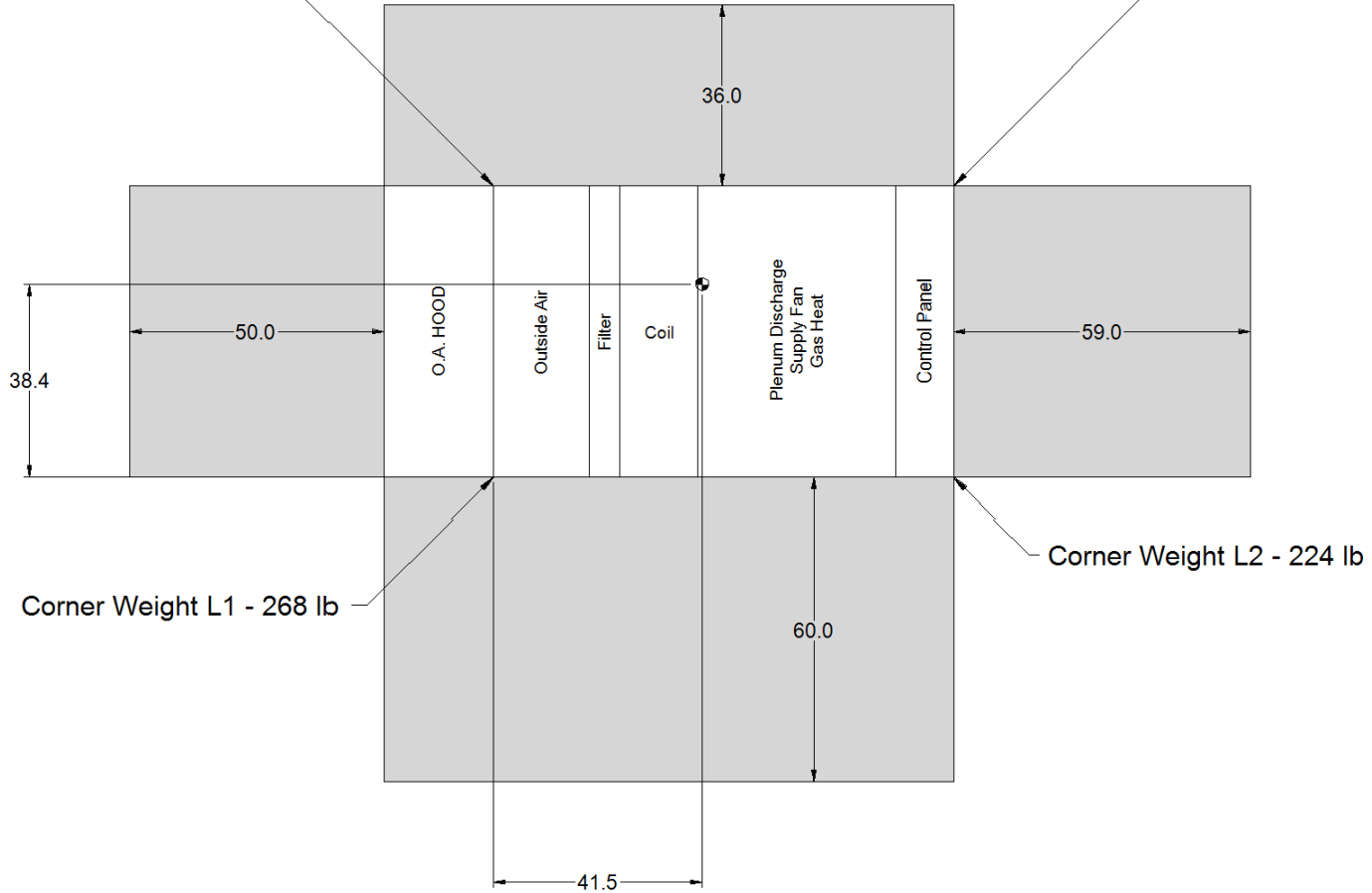

PLAN VIEW - CG, CORNER WEIGHTS, SERVICE CLEARANCE

Notes:

- (1) Center of Gravity Height = 27
- (2) Total Weight = 1454 lb

	Unit Tag: RTU-8		Sales Office: HTS Engineering Ltd.				 13600 Industrial Park Blvd. Minneapolis, MN 55441 www.DaikinApplied.com Software Version: 14.10
Product: Rebel	Project Name: 22600705 - DCDSB Archbishop		Sales Engineer:				
Model: DAHA07A	Apr. 07, 2026	Ver/Rev:	Sheet: 1 of 1	Scale: NTS	Tolerance: +/- 0.25"	Dwg Units: in [mm]	

No change to this drawing may be made unless approved in writing by Daikin Applied. Purchaser must determine that the equipment is fit and sufficient for the job specifications.

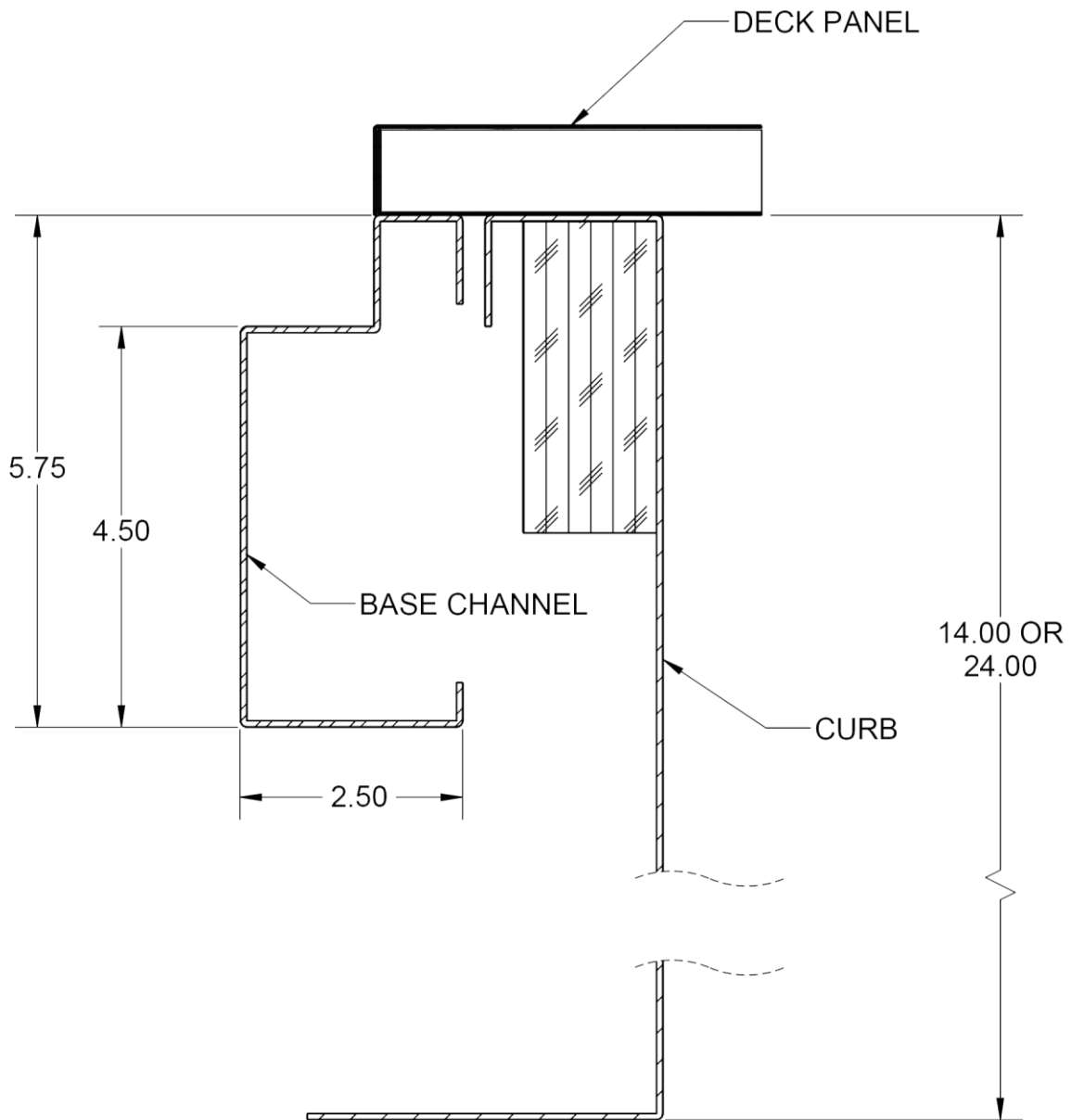

Curb Cross-Section View	Unit Tag: RTU-8			 13600 Industrial Park Blvd. Minneapolis, MN 55441 www.DaikinApplied.com Software Version: 14.10		
Product: Rebel	Project Name: 22600705 - DCDSB					
Model: DAHA07A	Sales Office: HTS Engineering Ltd.			Scale: NTS	Tolerance: +/-0.25"	Dwg Units: in [mm]
Sales Engineer:	Apr. 07, 2026	Ver/Rev:	Sheet 1 of 1	No change to this drawing may be made unless approved in writing by Daikin Applied. Purchaser must determine that the equipment is fit and sufficient for the job specifications.		

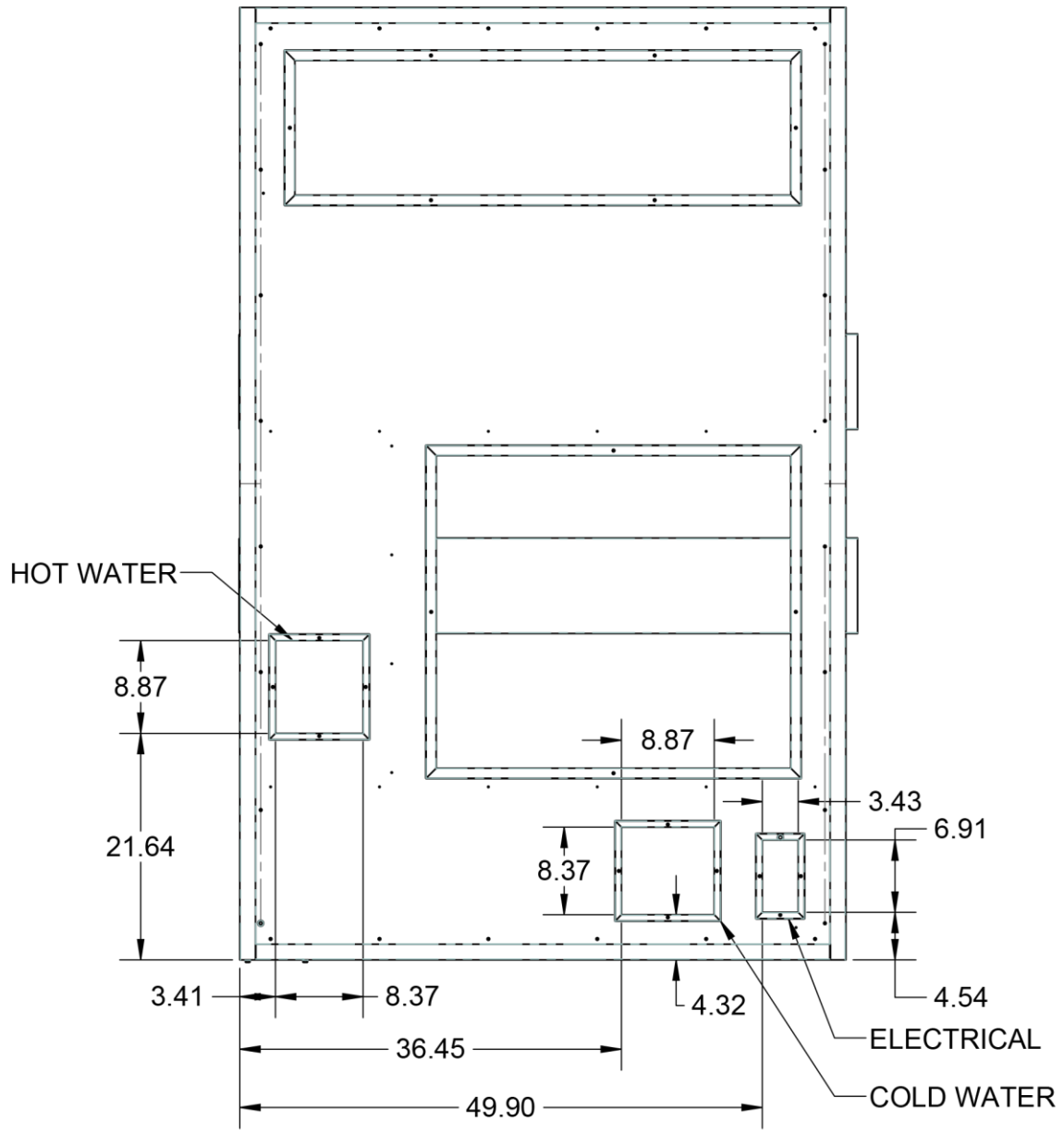

Plan View -Coil Piping Dimensions

Piping Entrance Locations View		Unit Tag: RTU-8		 13600 Industrial Park Blvd. Minneapolis, MN 55441 www.DaikinApplied.com Software Version: 14.10		
Product: Rebel		Project Name: 22600705 - DCDSB				
Model: DAHA07A		Sales Office: HTS Engineering Ltd.		Scale: NTS Tolerance: +/-0.25" Dwg Units: in [mm]		
Sales Engineer:		Apr. 07, 2026	Ver/Rev:	Sheet 1 of 1		
No change to this drawing may be made unless approved in writing by Daikin Applied. Purchaser must determine that the equipment is fit and sufficient for the job specifications.						



HTS Oshawa

2001 Thickson Rd, South
Unit #11
Whitby, ON L1N 6J3
T 905.579.6700
F 905.597.5290

ontario.htseng.com

SUBMITTAL DATA
APPROVAL REQUIRED

IOM LINK

https://htseng-my.sharepoint.com/:f:/g/personal/curtis_metrow_hts_com/IgD_JwPmhDmwQZINhdRqf-csAWEu08nbwsg2MnbpeWdmLds?e=AVpGVC